

TECHNICAL MANUAL

**OPERATOR, ORGANIZATIONAL,
DIRECT SUPPORT,
AND GENERAL SUPPORT MAINTENANCE
FOR**

**SHELTER, TACTICAL,
EXPANDABLE, TWO-SIDED**

NSN 5411-01-136-9838 60 AMP MODEL
NSN 5411-01-294-9866 100 AMP MODEL

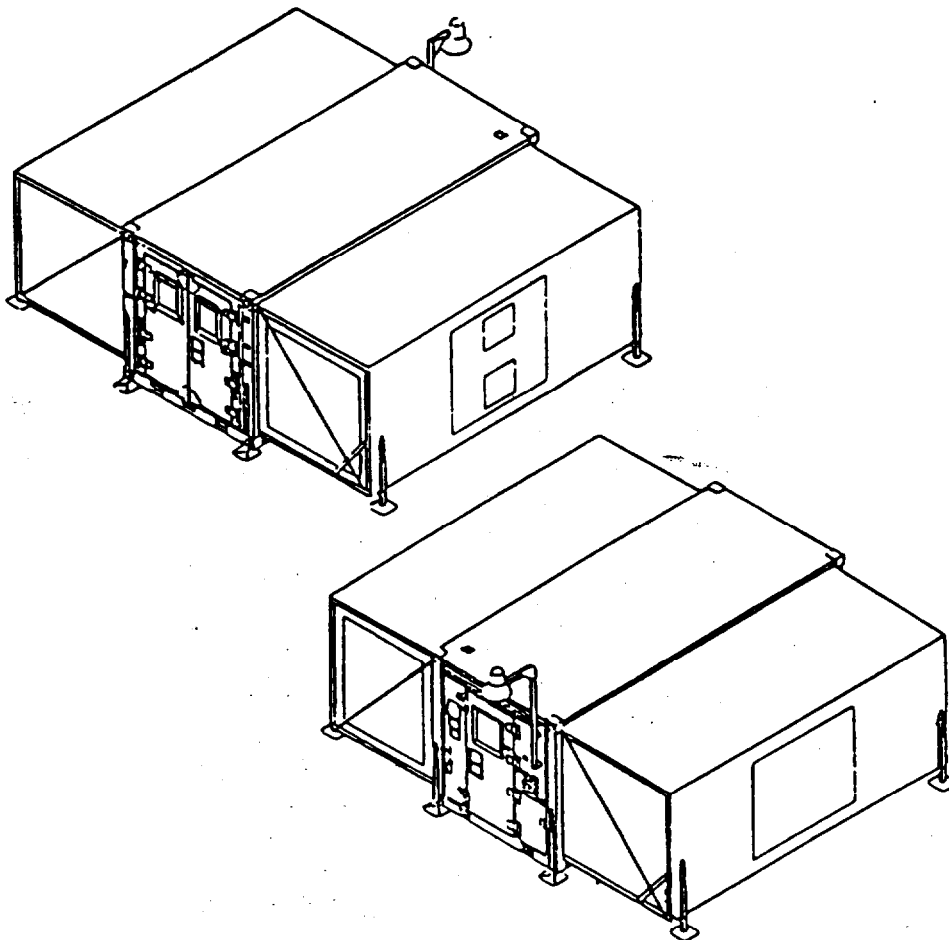

INTRODUCTION

Page 1-1

**OPERATING
INSTRUCTIONS**

Page 2-1

**OPERATOR
MAINTENANCE
INSTRUCTIONS**

Page 3-1

**ORGANIZATIONAL
MAINTENANCE
INSTRUCTIONS**

Page 4-1

**DIRECT SUPPORT
MAINTENANCE
INSTRUCTIONS**

Page 5-1

**GENERAL SUPPORT
MAINTENANCE
INSTRUCTIONS**

Page 6-1

REFERENCES

Page A-1

**MAINTENANCE
ALLOCATION
CHART**

Page B-1

**COMPONENTS OF END
ITEM AND BASIC
ISSUE ITEMS LIST**

Page C-1

**ADDITIONAL
AUTHORIZED LIST**

Page D-1

**EXPENDABLE
SUPPLIES AND
MATERIALS LIST**

Page E-1

HEADQUARTERS, DEPARTMENT OF THE ARMY

1 APRIL 1986

WARNING

HIGH VOLTAGE

exists in the electrical system of this equipment

DEATH ON CONTACT

may result if personnel fail to observe safety precautions

Before performing continuity checks or replacing electrical components, make sure that electrical power is completely disconnected from the circuit involved.

In the event of fluorescent lamp breakage, care must be taken in the removal of broken glass fragments and white phosphorous dust. Inhalation of phosphorous dust could cause dangerous injury.

Do not use handling equipment with capacity of less than gross weight of shelter system. Do not allow shelter to swing back and forth when it is suspended. Failure to observe this warning may result in damage to equipment or severe injury or death to personnel.

Methylethylketone (MEK) is flammable and toxic and must be used only in a well-ventilated area away from all sparks or open flame. Gloves should be worn during use.

Lock stop plate on load balancer with quick release pin before disconnecting support cable from hinged floor.

In extreme cold, do not touch metal parts with bare hands. Severe skin damage may result.

Safety glasses must be worn by personnel when installing ground anchors.

Expandable section (hinged floor and hinged sidewall together) weighs 700 pounds (318 kg). Do not stand directly in front of hinged section.

Support cables attached to hinged floor must be locked out prior to removal/installation of hinged sidewall.

Prior to removing load balancer from fixed roof, the hinged floor must be near stowed position to remove tension from support cable. The support cable bracket on hinged floor must then be removed to permit disconnecting support cable from hinged floor. Secure hinged floor to prevent accidental release.

Do not attempt to disassemble or repair load balancer. This equipment contains powerful torsion springs and serious injury or death to personnel could result if disassembled.

CHANGE
NO. 9

HEADQUARTERS, DEPARTMENT OF THE ARMY
AND THE AIR FORCE
WASHINGTON, DC, 31 AUGUST 2005

TECHNICAL MANUAL

OPERATOR, ORGANIZATIONAL, DIRECT SUPPORT AND GENERAL
SUPPORT MAINTENANCE
FOR
SHELTER, TACTICAL, EXPANDABLE, TWO-SIDED

NSN: 5411-01-136-9838
NSN: 5411-01-294-9866

DISTRIBUTION STATEMENT A: Approved for public release; distribution is unlimited.

TM 10-5411-200-14, 1 April 1986, is updated as follows:

1. File this sheet in front of the manual for reference.
2. This change implements Army Maintenance Transformation and changes the Maintenance Allocation Chart (MAC) to support Field and Sustainment Maintenance.
3. New or updated change information is indicated by a vertical bar in the outer margin of the page.
4. Remove old pages and insert new pages as indicated below:

Remove Pages

B-1 through B-11/(B-12 Blank)
Electronic 2028 Instructions
DA Form 2028

Insert Pages

A/(B Blank)
B-1 through B-12
Electronic 2028 Instructions/ Blank
2028 Sample Front/Back
2028 Front/2028 Back
2028 Front/2028 Back

By Order of the Secretary of the Army:

PETER J. SCHOOMAKER
General, United States Army
Chief of Staff

Official:

SANDRA R. RILEY
*Administrative Assistant to the
Secretary of the Army*
0521009

MICHAEL E. RYAN
GENERAL, USAF
Chief of Staff

Official:
GEORGE T. BABBETT
General, USAF
Commander, Air Force Materiel Command

Distribution: To be distributed in accordance with initial distribution number (IDN) 252533 requirements for TM 10-5411-200-14.

CHANGE
NO. 8

HEADQUARTERS DEPARTMENTS OF
THE ARMY AND THE AIR FORCE
WASHINGTON, D.C., 20 JANUARY 1997

Operator, Organizational, Direct Support, and General Support
Maintenance Manual

SHELTER, TACTICAL, EXPANDABLE, TWO-SIDED
NSN 5411-01-136-9838 (60 AMP MODEL)
NSN 5411-01-294-9866 (100 AMP MODEL)

DISTRIBUTION STATEMENT A: Approved for public release; distribution is unlimited

TM 10-5411-200-14/ T.O. 35E4-177-1,1 April 1986, is changed as follows:

1. The Cover is changed to add the 100 Amp Model.
2. Remove and insert pages as indicated below. New or changed text material is indicated by a vertical bar in the margin. An illustration change is indicated by a miniature pointing hand.

Remove pages	Insert pages
2-1 and 2-2	2-1 and 2-2
2-3 and 2-4	2-3 and 2-4
2-17 and 2-18	2-17 and 2-18
2- 8.1/ (2-18.2 blank)	2-18.1 through 2-18.3 (2-18.4 blank)
4-23 through 4-26	4-23 through 4-26
4-39 through 4-46	4-39 through 4-46
4-179 and 4-160	4-179 and 4-180
	4-180.1 and 4-180.2
4-181 and 4-182	4-181 and 4-182
	4-182.1 (4-182.2 blank)
4-185 and 4-186	4-185 and 4-186
	4-186.1/ (4-186.2 blank)
C-5/ (C-6 blank)	C-5/ (C-6 blank)
E-31 (E-4 blank)	E-3/ (E-4 blank)
Cover	Cover

3. Retain this sheet in front of manual for reference purposes.

ARMY TM 10-5411-200-14
AIR FORCE T.O.35E4-177-1
C8

By Order the Secretaries of the Army and Air Force:

Official:



Handwritten signature of Joel B. Hudson in black ink.

JOEL B. HUDSON

*Administrative Assistant to the
Secretary of the Army*

03151

DENNIS J. REIMER
*General, United States Army
Chief of Staff*

RONALD R. FOGELMAN
*General, USAF
Chief of Staff*

HENRY VICCELLIO, JR.
*General, USAF
Commander, Air Force Materiel Command*

DISTRIBUTION:

To be distributed in accordance with DA Form 12-25-E, block no. 2533, requirements for TM 10-5411-200-14.

CHANGE
NO. 7

HEADQUARTERS
DEPARTMENTS OF THE ARMY AND THE AIR FORCE
WASHINGTON, D. C., 15 December 1994

Operator, Organizational, Direct Support, and General Support
Maintenance Manual
For

SHELTER, TACTICAL EXPANDABLE, TWO-SIDED
(NSN 5411-01-136-9838) (60 Amp Model)
(NSN 5411-01-2949866) (100 Amp Model)

DISTRIBUTION STATEMENT A: Approved for public release; distribution is unlimited.

TM 10-5411-200-14/T.O. 35E4-177-1, 1 April 1986, is changed as follows:

1. Remove and insert pages as indicated below. New or changed text material is indicated by a vertical bar in the margin. An illustration change is indicated by a miniature pointing hand.

Remove pages

Insert pages

1-1 and 1-2
D-1/(D-2 blank)

1-1 and 1-2
D-1 and D-2

2. Retain this sheet in front of manual for reference purposes

TM 10-5411-200-14
T. O. 35E4-177-1
C 7

By Order of the Secretaries of the Army and Air Force:

Official:

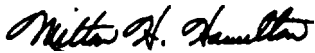

MILTON H. HAMILTON
*Administrative Assistant to the
Secretary of the Army*
0766

GORDON R. SULLIVAN
*General, United States Army
Chief of Staff*

MERRILL A. McPEAK
*General, USAF
Chief of Staff*

RONALD W. YATES
*General, USAF
Commander Air Force Materiel Command*

DISTRIBUTION:

To be distributed in accordance with DA Form 12-25-E, block no. 2533, requirements for
TM 10-5411-200-14.

CHANGE

NO. 6

HEADQUARTERS
DEPARTMENTS OF THE ARMY AND AIR FORCE
WASHINGTON, D. C., 28 February 1994

Operator, Organizational, Direct Support, and General
Maintenance Manual

SHELTER, TACTICAL, EXPANDABLE, TWO-SIDED
(NSN 5411-01-1.36-9838) (60 Amp Model)
(NSN 5411-01-294-9866) (100 Amp Model)

DISTRIBUTION STATEMENT A: Approved for public release; distribution is unlimited.

TM 10-5411-200-14/T. O. 35E4-177-1, 1 April 1986, is changed as follows:

1. Remove and insert pages as indicated below. New or changed text material is indicated by a vertical bar in the margin. An illustration change is indicated by a miniature pointing hand.

Remove pages

i and ii
2-31 and 2-32
C-3 and C-4

Insert pages

i and ii
2-31 and 2-32
C-3 and C-4

2. Retain this sheet in front of manual for reference purposes.

By Order of the Secretaries of the Army and Air Force:

Official:

MILTON H. HAMILTON
*Administrative Assistant to the
Secretary of the Army*
06236

GORDON R. SULLIVAN
*General, United States Army
Chief of Staff*

MERRILL A. McPEAK
*General, USAF
Chief of Staff*

Official:

RONALD W. YATES
*General, USAF
Commander Air Force Materiel Command*

DISTRIBUTION:

To be distributed in accordance with DA Form 12-25-E, block no. 2533, requirements for
TM 10-5411-200-14.

CHANGE
NO. 5

HEADQUARTERS
DEPARTMENTS OF THE ARMY AND AIR FORCE
WASHINGTON, D. C. , 30 JULY 1993

Operator, Organizational, Direct Support, and General Support
Maintenance Manual

SHELTER, TACTICAL, EXPANDABLE, TWO-SIDED
(NSN 5411-01-136-9838) (60 Amp Model)
(NSN 5411-01-294-9866) (100 Amp Model)

DISTRIBUTION STATEMENT A: Approved for public release; distribution is unlimited.

TM 10-5411-200-14/T.O. 35E4-177-1, 1 April 1986, is changed as follows:

1. Remove and insert pages as indicated below. New or changed text material is indicated by a vertical bar in the margin. An illustration change is indicated by a miniature pointing hand.

Remove pages

4-93 through 4-96
4-99 through 4-108

Insert pages

4-93 through 4-96
4-99 through 4-108

2. Retain this sheet in front of manual for reference purposes.

TM 10-5411-200-14
T. O. 35E4-177-1

By Order of the Secretaries of the Army and Air Force:

Official:

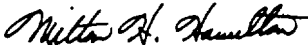
MILTON H. HAMILTON
*Administrative Assistant to the
Secretary of the Army*
04990

GORDON R. SULLIVAN
*General, United States Army
Chief of Staff*

official:

RONALD W. YATES
*General, USAF
Commander Air Force Materiel Command*

MERRILL A. McPEAK
*General, USAF
Chief of Staff*

DISTRIBUTION:

To be distributed in accordance with DA Form 12-25-E, block no. 2533, requirements for
TM 10-5411 -200-14.

CHANGE

NO. 4

HEADQUARTERS,
DEPARTMENTS OF THE ARMY AND AIR FORCE
WASHINGTON, D. C. 30 April 1993

Operator, Organizational, Direct Support, and General Support
Maintenance Manual

SHELTER, TACTICAL, EXPANDABLE, TWO-SIDED
NSN 5411-01-136-9838 (60 AMP MODEL)
NSN 5411-01-294-9866 (100 AMP MODEL)

DISTRIBUTION STATEMENT A: Approved for public release; distribution is unlimited.

TM 10-5411-200-14/T.O. 35E4-177-1, 1 April 1986 is changed as follows:

1. Remove and insert pages as indicated below. New or changed text material is indicated by a vertical bar in the margin. An illustration change is indicated by a miniature pointing hand.

Remove pages

4-171 and 4-172
D-1/(D-2 blank)
E-1 through E-3/(E-4 blank)

Insert pages

4-171 and 4-172
D-1/(D-2 blank)
E-1 through E-3/(E-4 blank)

2. Retain this sheet in front of manual for reference purposes.

By Order of the Secretaries of the Army and Air Force:

Official:

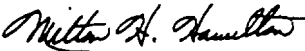
MILTON H. HAMILTON
*Administrative Assistant to the
Secretary of the Army*
04078

GORDON R. SULLIVAN
*General, United States Army
Chief of Staff*

MERRILL A. McPEAK
*General, USAF
Chief of Staff*

Official:

RONALD W. YATES
*General, USAF
Commander, Air Force Materiel Command*

DISTRIBUTION:

To be distributed in accordance with DA Form 12-25-E, block no. 2533, requirements for
TM 10-5411 -200-14..

CHANGE

NO. 3

HEADQuARTERS,
DEPARTMENTS OF THE ARMY AND AIR FORCE
WASHINGTON, D. C. , 23 May 1991

Operator, Organizational, Direct Support and General Support
Maintenance Manual

SHELTER, TACTICAL, EXPANDABLE, TWO-SIDED
NSN 5411-01-1369838 (60 AMP MODEL)
NSN 541141-294-9866 (100 AMP MODEL)

Approved for public release; distribution is unlimited

TM 10-5411-200-14/T. O. 35E4-177-1, 1 April 1986 is changed as follows:

1. Remove and insert pages as indicated below. New or changed text material is indicated by a vertical bar in the margin. An illustration change is indicated by a miniature pointing hand.

Remove pages

1-1 and 1-2

1-5 and 1-6

C-3 and C-4

Insert pages

1-1 and 1-2

1-5 and 1-6

C-3 and C-4

2. Retain this sheet in front of manual for reference purposes.

ARMY TM 10-5411-200-14
AIR FORCE T. O. 35E4-177-1
C 3

By Order of the Secretaries of the Army and Air Force:

CARL E. VUONO
General, United States Army
Chief of Staff

Official:

PATRICIA P. HICKERSON
Colonel, United States Army
The Adjutant General

MERRILL A. McPEAK
General USAF
Chief of Staff

Official:

CHARLES C. McDONALD
General, USAF
Commander, Air Force Logistics Command

DISTRIBUTION:

To be distributed in accordance with DA Form 12-25E, (qty req block no. 2533).

CHANGE

HEADQUARTERS, DEPARTMENTS OF
THE ARMY AND THE AIR FORCE
WASHINGTON, D. C. , 14 February 1990

No. 2

Operator, Organizational, Direct Support,
And General Support Maintenance

SHELTER, TACTICAL, EXPANDABLE, TWO-SIDED
(NSN 5411-01-136-9838) (60 Amp Model)
(NSN 5411-01-294-9866) (100 Amp Model)

Approved for public release; Distribution is unlimited.

TM 10-5411-200-14/T. O. 35E4-177-1, 1 April 1986, is changed as follows:

1. Title is changed as shown above.
2. Remove and insert pages as indicated below. New or changed text material is indicated by a vertical bar in the margin. An illustration change is indicated by a miniature pointing hand.

Remove pages

i and ii
1-1 through 1-6
2-1 and 2-2
2-9 through 2-14
2-17 and 2-18

2-21 through 2-24

2-29 and 2-30
3-7 and 3-8
4-.5 through 4-12

4-13 and 4-14
4-27 through 4-36
4-47 through 4-54

4-55 and 4-56
4-179 through 4-186

5-5 through 5-8
A-1/A-2
D-1/D-2
E-1 and E-2

Index 1 through Index 4

Insert pages

i and ii
1-1 through 1-6
2-1 and 2-2
2-9 through 2-14
2-17 and 2-18
2-18.1/2-18.2
2-21 through 2-24
2-24.1/2-24.2
2-29 and 2-30
3-7 and 3-8
4-5 through 4-12
4-12.1 and 4-12.2
4-13 and 4-14
4-27 through 4-36
4-47 through 4-54
4-54.1 and 4-54.2
4-55 and 4-56
4-179 through 4-186
4-187 through 4-190
5-5 through 5-8
A-1/A-2
D-1/D-2
E-1 and E-2
E-3/E-4
Index 1 through Index 4

TM 10-5411-200-14
T.O. 35E4-177-1
C 2

3. Retain this sheet in front of manual for reference purposes.

By Order of the Secretaries of the Army and the Air Force:

CARL E. VUONO
General, United States Army
Chief of Staff

Official:
WILLIAM J. MEEHAN, II
Brigadier General, United States Army
The Adjutant General

LARRY D. WELCH, General USAF
Chief of Staff

Official:
ALFRED G. HANSEN
General, USAF, Commander, Air Force
Logistics Command

DISTRIBUTION:

To be distributed in accordance with DA 12-25A, Operator, Unit, Direct Support and General Support Maintenance requirements for Shelter, Expandable, 2-Side (5-4-3118-2).

CHANGE

No. 1

HEADQUARTERS
DEPARTMENTS OF THE ARMY AND AIR FORCE
WASHINGTON, D. C., 8 June 1989

Operator, Organizational, Direct Support
and General Support Maintenance

SHELTER, TACTICAL, EXPANDABLE, TWO-SIDED
(NSN 5411-01-136-9838)

Approved for public release. Distribution is unlimited.

TM 10-5411-200-14/T.O. 35E4-177-1, 1 April 1986, is changed as follows:

1. Remove and insert pages as indicated below. New or changed text material is indicated by a vertical bar in the margin, An illustration change is indicated by a miniature pointing hand.

Remove pages

2-29 and 2-30
D-1/D-2

Insert pages

2-29 and 2-30
D-1/D-2

2. Retain this sheet in front of manual for reference purposes.

By Order of the Secretaries of the Army and the Air Force:

CARL E. VUONO
*General United States Army
Chief of Staff*

Official:

WILLIAM J. MEEHAN, II
*Brigadier General, United States Army
The Adjutant General*

LARRY D. WELCH, General USAF
Chief of Staff

Official:

ALFRED G. HANSEN
*General, USAF, Commander, Air Force
Logistics Command*

DISTRIBUTION:

To be distributed in accordance with DA Form 12-25A, Operator, Unit, Direct Support and General Support Maintenance requirements for Shelter, Expandable, Rigid Construction, W/Air Lock Model SEU-2 (TM 10-5410-221 Series) and for Shelter, Expandable, Shop, Aircraft Maintenance, Portable (TM 10-5410-224 Series).

INSERT LATEST CHANGED PAGES. DESTROY SUPERSEDED PAGES.

LIST OF EFFECTIVE PAGES

NOTE: The portion of text affected by the update is indicated by a vertical line in the outer margins of the page. Updates to illustrations are indicated by shaded or screened areas, or by miniature pointing hands. Zero in the "Change No." column indicates an original page or work package.

Dates of issue for original and changed pages / work packages are:

Original .. 0 ..	1 April 1986	Change .. 5 ..	30 July 1993
Change .. 1 ..	8 June 1989	Change .. 6 ..	28 February 1994
Change .. 2 ..	14 February 1990	Change .. 7 ..	15 December 1994
Change .. 3 ..	23 May 1991	Change .. 8 ..	20 January 1997
Change .. 4 ..	30 April 1993	Change .. 9 ..	31 August 2005

TOTAL NUMBER OF PAGES FOR THIS PUBLICATION IS 350, CONSISTING OF THE FOLLOWING:

Page No.	Change No.	Page No.	Change No.	Page No.	Change No.	Page No.	Change No.
Cover	0	2-15 through 2-17	0	4-26	8	5-5	2
a/(b Blank)	0	2-18 through 2-18.3/(2-18.4 Blank)	8	4-27	0	5-6	0
i	6	2-19 through 2-21	0	4-28 through 4-36	2	5-7	2
ii	2	2-22	2	4-37 through 4-39	0	5-8 through 5-14	0
1-0	0	2-23	0	4-40 through 4-45	8	6-1 through 6-4	0
1-1	2	2-24 through 2-24.1/(2-24.2 Blank)	2	4-46	0	A-1/(A-2 blank)	2
1-2	7	2-25 through 2-28	0	4-47 through 4-55	2	B-1 through B-12	9
1-3	2	2-29 through 2-30	2	4-56 through 4-92	0	C-1 through C-3	0
1-4	0	2-31	6	4-93 through 4-95	5	C-4	6
1-5	3	2-32 through 2-36	0	4-96 through 4-99	0	C-5/(C-6 blank)	8
1-6	2	3-1 through 3-7	0	4-100 through 4-108	5	D-1 through D-2	7
2-1	8	3-8	2	4-109 through 4-179	0	E-1	0
2-2	2	3-9 through 3-15/(3-16 Blank)	0	4-180 through 4-182.1/(4-182.2 Blank)	8	E-2	4
2-3	8	4-1 through 4-4	0	4-183	2	E-3/(E-4 blank)	8
2-4 through 2-8	0	4-5 through 4-13	2	4-184 through 4-185	0	Index-1	2
2-9 through 2-12	2	4-14 through 4-22	0	4-186 through 4-186.1/(4-186.2 Blank)	8	Index-2	0
2-13	0	4-23 through 4-24	8	4-187 through 4-190	2	Index-3 through Index-4	2
2-14	2	4-25	0	5-1 through 5-4	0	Back Cover	0

TECHNICAL MANUAL
NO. 10-5411-200-14

HEADQUARTERS, DEPARTMENTS OF
THE ARMY AND THE AIR FORCE
WASHINGTON, D.C., 1 April 1986

OPERATOR, ORGANIZATIONAL, DIRECT SUPPORT,
AND GENERAL SUPPORT MAINTENANCE

SHELTER, TACTICAL, EXPANDABLE, TWO-SIDED
(NSN 5411-01-136-9838)(60 Amp Model)
(NSN 5411-01-294-9866)(100 Amp Model)

DISTRIBUTION STATEMENT A: Approved for public release; distribution is unlimited

REPORTING ERRORS AND RECOMMENDING IMPROVEMENTS

You can help improve this manual. If you find any mistakes or if you know of a way to improve the procedures, please let us know. Reports shall be submitted as follows: A reply will be furnished to you.

(A) Army - DA Form 2028 (Recommended Changes to Publications and Blank Forms), or DA Form 2028-2 located in the back of this manual direct to: Commander, U.S. Army Aviation and Troop Command, ATTN: AMSAT-I-MP, 4300 Goodfellow Boulevard, St. Louis, MO 63120-1798.

(F) Air Force - AFTO Form 22 directly to: Commander, Sacramento Air Logistics Center, ATTN: MMST, McClellan Air Force Base, CA 95652 in accordance with TO-00-5-1,

TABLE OF CONTENTS

	Page	
CHAPTER 1	INTRODUCTION	1-1
Section I.	General Information	1-1
Section II.	Equipment Description and Data	1-3
CHAPTER 2	OPERATING INSTRUCTIONS	2-1
Section I.	Description and Use of Operator's Controls and Indicators	2-1
Section II.	Operator's Preventive Maintenance Checks and Services (PMCS)	2-4
Section III.	Service Upon Receipt of Shelter	2-11
Section IV.	Operation Under Usual Conditions	2-32
Section V.	Operation Under Unusual Conditions	2-33
CHAPTER 3	OPERATOR MAINTENANCE INSTRUCTIONS	3-1
Section I.	Troubleshooting Procedures	3-1
Section II.	Operator Maintenance Procedures	3-4

TABLE OF CONTENTS (cont)

		Page
CHAPTER 4	ORGANIZATIONAL MAINTENANCE INSTRUCTIONS	4-1
Section I	Repair Parts, ,Special Tools, TMDE, and Support Equipment	4-1
Section II.	Troubleshooting Procedures	4-2
Section III.	Organizational Maintenance Procedures	4-5
Section IV.	Preparation for Storage and Shipment	4-190
CHAPTER 5	DIRECT SUPPORT MAINTENANCE INSTRUCTIONS	5-1
CHAPTER 6	GENERAL SUPPORT MAINTENANCE INSTRUCTIONS	6-1
APPENDIX A	REFERENCES	A-1
APPENDIX B	MAINTENANCE ALLOCATION CHART	B-1
APPENDIX C	COMPONENTS OF END ITEM AND BASIC ISSUE ITEMS LIST	C-1
APPENDIX D	ADDITIONAL AUTHORIZED LIST	D-1
APPENDIX E	EXPENDABLE SUPPLIES AND MATERIALS LIST	E-1
ALPHABETICAL INDEX		INDEX-1

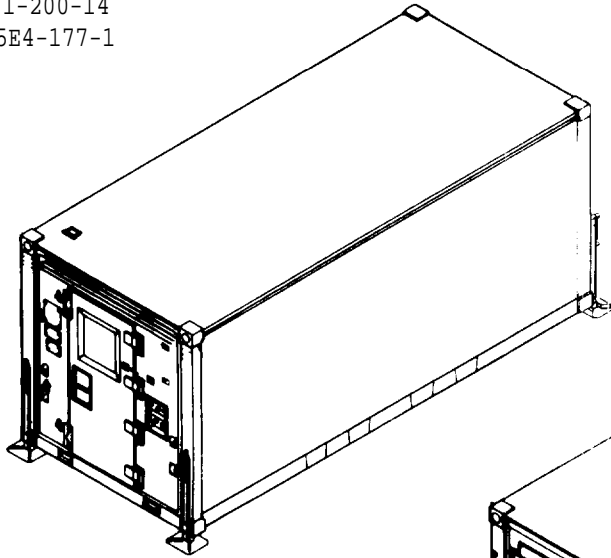

FRONT VIEW

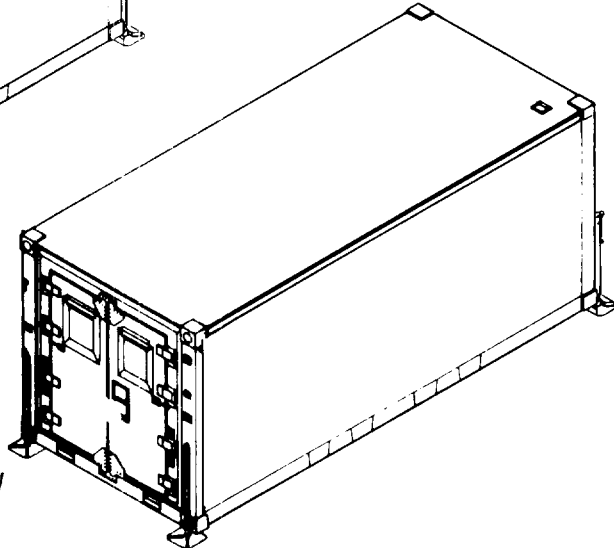

REAR VIEW

STOWED SHELTER

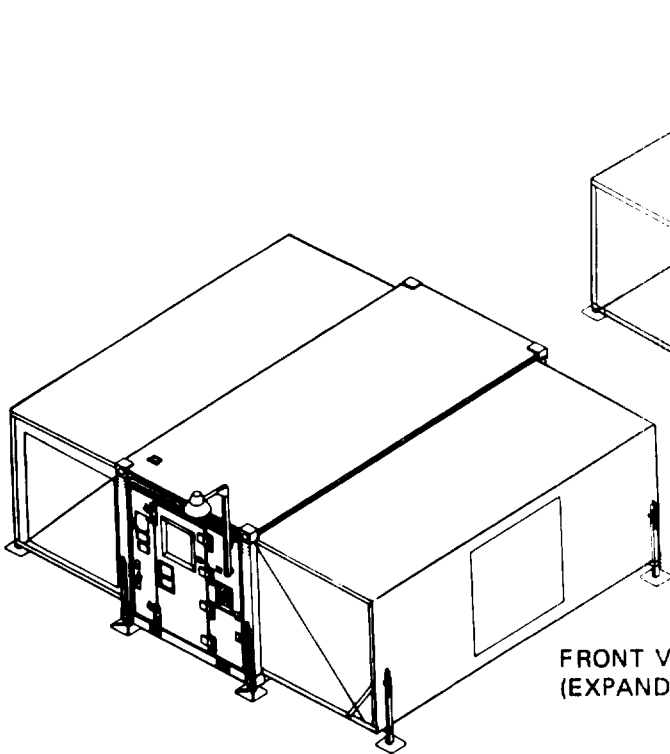

FRONT VIEW
(EXPANDED)

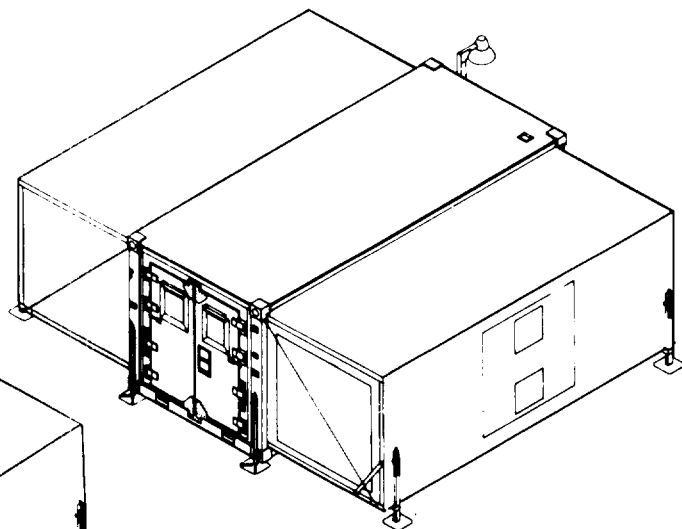

REAR VIEW
(EXPANDED)

EXPANDED SHELTER

Full External View of Two-Sided Expandable Tactical Shelter

CHAPTER 1

INTRODUCTION

Section 1. GENERAL INFORMATION

1-1. SCOPE. This manual is for use by personnel responsible for operation and maintenance of the two-sided expandable tactical shelter assembly, which will be referred to as the shelter. It provides the user with necessary instructions to use the shelter and to perform required maintenance in accordance with the Maintenance Allocation Chart in Appendix B.

NOTE

Some portions of this publication are not applicable to all services. These portions are prefixed to indicate the services to which they pertain (A) for Army, (F) for Air Force, and (N) for Navy. Portions not prefixed are applicable to all services.

1-2. MAINTENANCE FORMS, RECORDS, AND REPORTS. Maintenance forms, records, and reports used by:

- a. (A) Are prescribed by DA PAM 736-750, the Army Maintenance Management System (TAMMS).
- b. (F) Are prescribed in AFM-66-1 and the applicable 00-20 Series Technical Orders.
- c. (N) Refer to their service peculiar directives to determine applicable maintenance forms and records to be used.
- d. (A) Users shall refer to the Maintenance Allocation Chart (MAC) for task and levels of maintenance to be performed. Where the density of equipment is not sufficient to authorize unit personnel with skills necessary to perform unit-level maintenance functions, AR 750-1, paragraph 2-8c states, "Unserviceable repairable, (properly preserved, protected, and tagged) that are beyond the authorized capability or capacity to repair, will be evacuated through the appropriate SUPPLY support activities for repair or exchange." For units authorized personnel with skills to perform greater than unit-level maintenance functions, AR 750-1, paragraph 2-9b states, "DS and GS units may grant authority to supported units to perform the next higher level repair, if the supported unit has the capability and capacity to perform the repair."

(F) Users shall accomplish maintenance at the user level consistent with their capability in accordance with policies established in AFM 66-1.

- f. (N) Users shall determine their maintenance levels in accordance with their service directives.

1-3. (A) DESTRUCTION OF MATERIEL TO PREVENT ENEMY USE. For destruction procedures for materiel refer to TM 750-244-3.

14. ADMINISTRATIVE STORAGE. For procedures and inspections required during administrative storage, refer to Chapter 4, paragraph 4-44.

1-5. (A) REPORTING EQUIPMENT IMPROVEMENT RECOMMENDATIONS (EIR'S). If your shelter needs improvement, let us know. Send us an EIR. You, the user, are the only one who can tell us what you don't like about your equipment. Let us know why you don't like the design. Tell us why a procedure is hard to perform. Put it on an SF 368 (Quality Deficiency Report). Mail it to: Commander, U. S. Army Aviation and Troop command ATTN: AMSAT-I-MDO, 4300 Goodfellow Boulevard, St. Louis, Missouri, 63120-1798. We'll send you a reply.

1-6. LIST OF ABBREVIATIONS.

AC	Air conditioner
cm	centimeter
ECU	Environmental Control Unit
EIR	Equipment Improvement Report
ft	foot (feet)
Hz	Hertz
in.	inch
ISO	International standards Organization
kg	Kilogram
lb	pound
lg	long
MAC	Maintenance Allocation chart
MEK	Methylethylketone (Solvent)
m m	millimeter
MTOE	Modified Table of Organization and Equipment
No.	number
PMCS	Preventive Maintenance Checks and Services
ref	reference
sq	square
TMDE	Test, Measurement and Diagnostic Equipment
W C	Volts, alternating current

Section II. EQUIPMENT DESCRIPTION AND DATA

1-7. PURPOSE OF TWO-SIDED EXPANDABLE TACTICAL SHELTER ASSEMBLY. A self-contained transportable multi-application utility shelter. A member of family of standard rigid wall ISO shelters to be used by branches of the Department of Defense.

Capabilities and Features:

- Equipped with standard ISO fittings for easy transportability.
- Provided with mobilizer fittings for mobilizer transportation.
- Built-in fork lift provisions.
- All weather operation.
- Environmentally controlled interior.
- Rigid wall construction.
- Simple and fast deployment.
- Designed to operate under blackout conditions with door activated blackout switch.
- External electrical power connection.
- Easy to maintain.

Differences Between Models:

- The early model Shelter, Tactical, Expandable, Two-Sided (NSN 5411-01-138-9838), provides overload protection through a 60 amp or 100 amp Model NQOB circuit breaker panel, manufactured by Square D Company. When replacement of the circuit breaker panel is necessary, the replacement will be Model NQOD circuit breaker panel, which is also manufactured by Square D Company and has the capability to accommodate either 60 amp or 100 amp service. Model NQOD is two inches shorter in length than the earlier Model NQOB, and modifications to the shelters are required when replacement is necessary (see paragraph 4-7.1).

NOTE

All electrical components (circuit breakers, switches, and wiring) used in the earlier model circuit breaker panel are compatible with the new Model NQOD.

- The late model Shelters, Tactical, Expandable, Two-Sided (NSN 5411-01-294-9866) are initially equipped with the new Model NQOD circuit breaker panel when placed into service.

1-8. LOCATION AND DESCRIPTION OF MAJOR COMPONENTS.

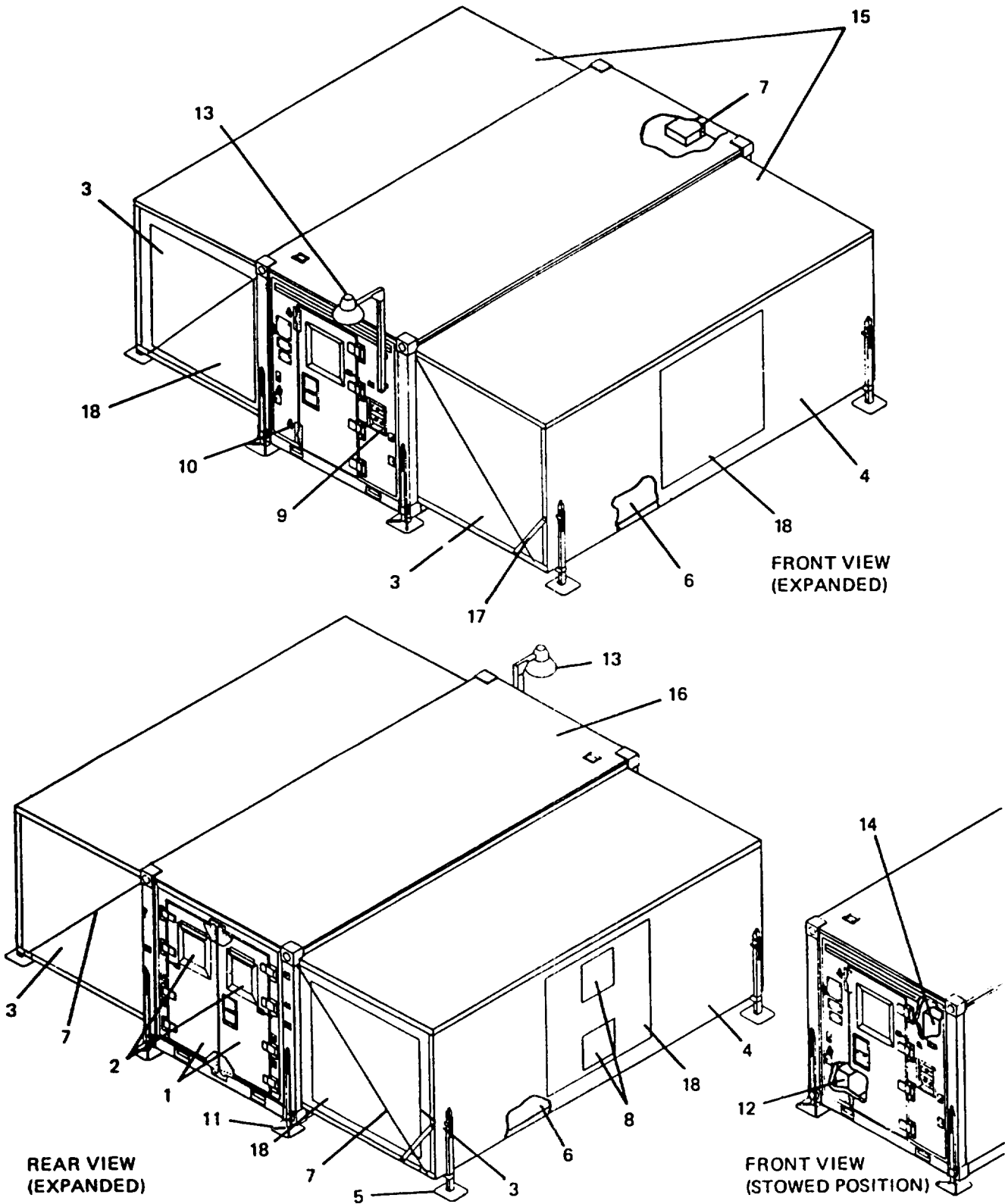

1-8. (cont)

1. LEFT AND RIGHT CARGO DOORS, Provides access to shelter for delivery of bulky materiel and equipment.

W A R N I N G

Door vents are spring loaded to swing upward. To prevent injury, hold door vent shut while unlatching all the retaining clips.

2. DOOR VENTS. Manually operated vents provide ventilation and pressure equalization for the shelter.
3. HINGED ENDWALLS. Hinged to center structure and swing out to form walls in the expandable section of shelter.
4. HINGED SIDEWALL. Hinged to hinged floor panel. Forms a wall in the expandable section when shelter is expanded.
5. LEVELING JACKS. Secured to hinged floor and hinged sidewall. Provides leveling means for the expandable section.
6. HINGED FLOOR PANEL. Hinged to fixed floor panel. Provides additional floor space when shelter is expanded.
7. EXPANDABLE SIDE LOAD BALANCER. Consists of cable reels, cable guides, and support cable to assist in expanding and closing of hinged floor panel and hinged sidewall.
8. ECU PANELS. Provides for connections of ECU equipment used with shelter

W a r n i n g

Shelter grounding is not optional on shelters used for Deployable Medical Systems (DEPMEDS).

9. POWER ENTRY PANEL. A service entrance connector on this panel receives external primary input power for shelter and routes it to a circuit breaker panel inside the shelter. Includes provisions for optional shelter grounding and telephone connections.
10. FIXED PERSONNEL DOOR. Provides access to shelter. The only door used during blackout conditions.
11. CONTAINER LIFT JACKS. Provides leveling means for fixed section of shelter by means of 150 fittings.
12. EQUIPMENT CONTAINER CHEST. Contains leveling jack extensions, storm configuration (shelter tie-down) kit, area light incandescent bulb, removable latches, support braces, and screwdriver.
13. AREA LIGHT. Attaches to either personnel or cargo endwall panels to provide illumination at either end of shelter. Plugs into receptacle on power entry panel.
14. CIRCUIT BREAKER PANEL. Provides overload protection for shelter circuits. Main circuit breaker switches off all electrical power to shelter.
15. HINGED ROOF PANEL. Hinged to center structure roof. Swings up to provide roof for expandable section of the shelter.

1-8. (cont)

- 16. FIXED PANELS. Consists of personnel and cargo end, fixed floor, and fixed roof panels. Used for equipment storage during transportation. All hinged panels are hinged to fixed container.
- 17. SUPPORT BRACES. Provides support to hinged sidewall during expanding procedures only.
- 18. CLOSEOUT PANELS. Used to cover openings in endwalls and sidewalls.

1-9. EQUIPMENT DATA.

Exterior Dimensions (Stowed Shelter)

Width.	8 ft. (2.44 meters)
Height.	8 ft. (2.44 meters)
Length.	19 ft., 10-1/2 i. (6.05 meters)

Exterior Dimensions (Expanded Shelter)

Width.	21 ft., 9 in. (6.63 meters)
Height.	8 ft., (2.44 meters)
Length.	19 ft., 10-1/2 in. (6.05 maters)

Interior Dimensions

Minimum clear height	80.29 in. (2.04 meters)
Minimum clear width (stowed mode)	77.78 in. (1.98 meters)
Usable floor space	400 sq. ft. (37.2 sq. meters)

Total Weights

Less payload	6,900 lbs. (3130 kg)
With payload (maximum)	15,000 lbs. (6804 kg)

Primary Power Requirements

NQOB Model	120/208 Vat, 60 Hz, 3 phase, 4 wire with 1 grid.
NQOD Model	120/208 Vac, 60 Hz, 3 phase, 4 wire with 4 grids.

Environmental Limits

Operating temperature	-65°F to +125°F (-53.9°C to 51.7°C)
---------------------------------	-------------------------------------

Transportability (Stowed Shelter)

ISO fittings	Provided with upper and lower ISO fittings in accordance with specification ISO 1496/1.
Dolly Set	Equipped with mobilizer fittings for transportation with mobilizer. Model No. M832- 10,000 pounds (4546 Kg) maximum capacity (TM 9-2330-275-14&P). Model No. M1022 15,000 pounds (6804 Kg) maximum capacity (TN 9-2330-379-14&P).
Fork Lift	Built-in fork lift provisions.

CHAPTER 2
OPERATING INSTRUCTIONS

Section I. DESCRIPTION AND USE OF OPERATOR'S CONTROLS AND INDICATORS

2-1. SCOPE. This section provides description and use of operator controls and indicators needed to operate shelter. This section provides descriptions for circuit breaker panel controls and indicators (See paragraph 2-2) and personnel end panel mounted controls and indicators (See paragraph 2-3).

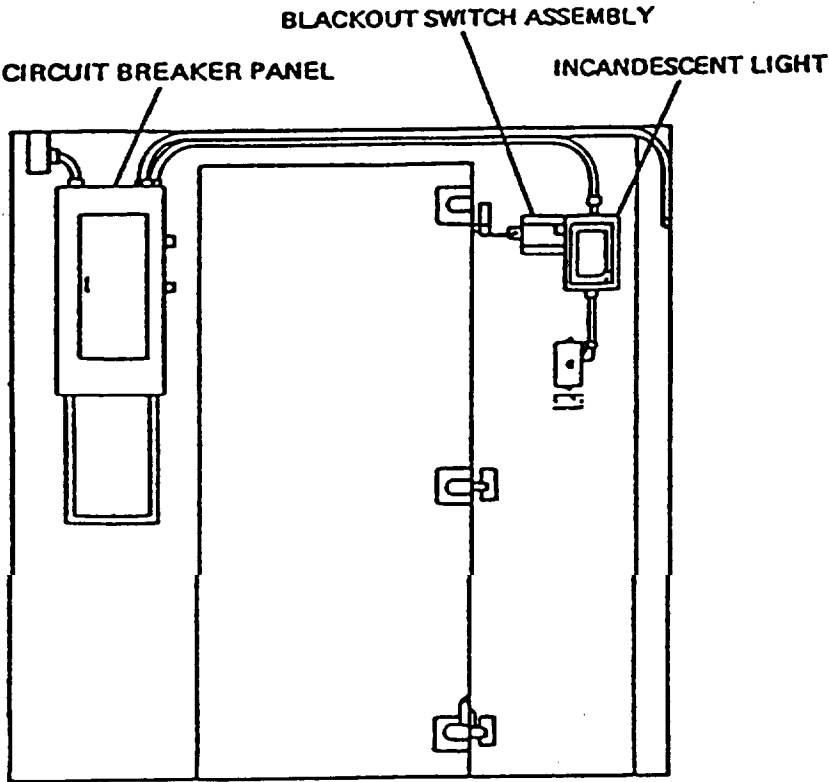

PRIOR TO S/N 1089

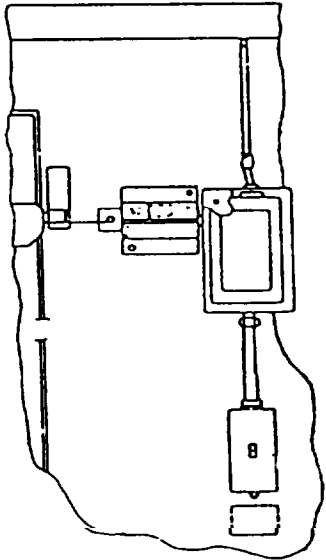

INSIDE VIEW - LOOKING AT PERSONNEL END PANEL

2-2. CIRCUIT BREAKER PANEL CONTROLS AND INDICATORS

Control or Indicator

Function

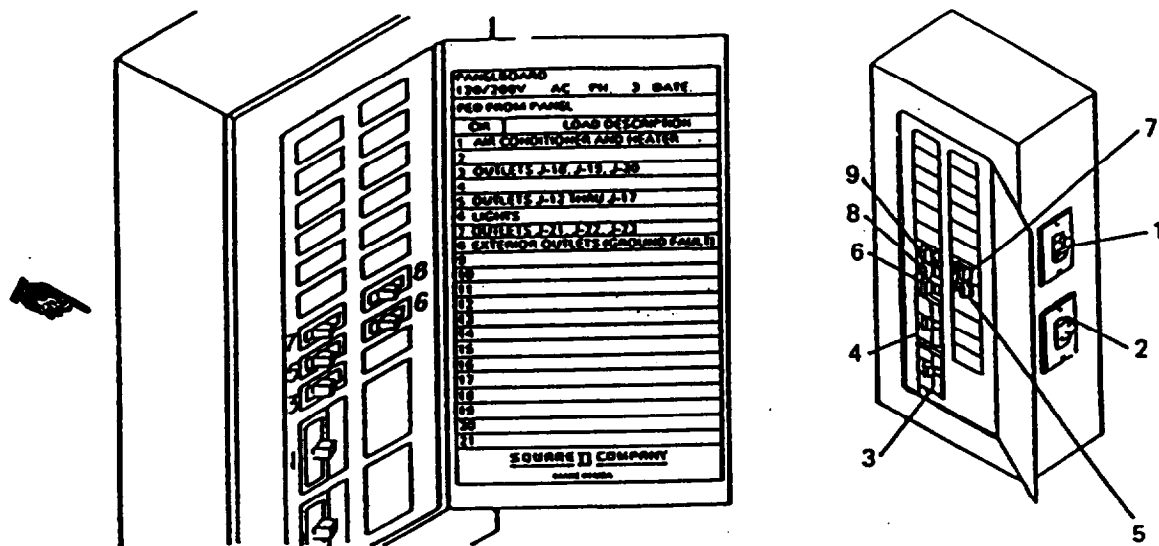

1 Blackout override switch

In ON position, overrides door activated blackout switch mounted on personnel end panel adjacent to personnel door. During blackout conditions, must be in OFF position. Circuit protected against overload by circuit breaker.

2 Incandescent light switch

In ON position, turns on wall mounted incandescent light. In OFF position, turns off wall mounted incandescent light. Circuit protected against overload by circuit breaker.

3 Main circuit breaker

In ON position, delivers electrical power to individual circuit breakers. In OFF position, turns off all electrical power in shelter.

4 Circuit breaker

Provides overload protection for heater/ac supply receptacle mounted on power entry panel.

5 Circuit breaker

Provides overload protection for incandescent light, blackout circuit mounted on fixed personnel endwall and all fluorescent lights in shelter.

2-2. (cont)

	Control or Indicator	Function
6	Circuit breaker	Provides overload protection for interior utility outlets mounted on sidewall.
7	Circuit breaker	Provides overload protection for ground fault interrupter utility outlet mounted on power entry panel.
8	Circuit breaker	Provides overload protection for interior utility outlets mounted on hinged sidewall and hinged endwalls.
9	Circuit breaker	Provides overload protection for interior utility outlets mounted on hinged sidewall and hinged endwalls.

2-3. PERSONNEL END PANEL MOUNTED CONTROLS AND INDICATORS

	Control or Indicator	Function
1	Door activated blackout switch	During blackout conditions it turns off all lights in shelter when fixed end personnel door is opened. To override operation of this switch, the circuit breaker panel mounted blackout override switch must be in ON position. Circuit protected against overload by circuit breaker.
2	Ceiling lights switch	In ON position, turns on nine fluorescent lights in shelter. In OFF position turns off all fluorescent lights. Circuit protected against overload by circuit breaker.

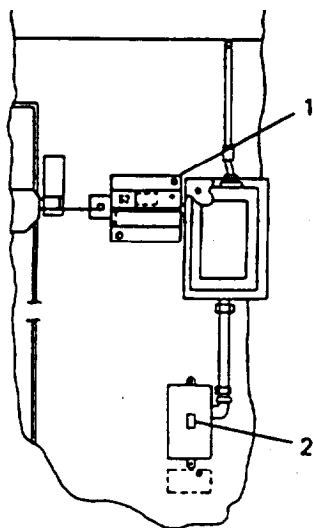

PRIR TO S/N 1089

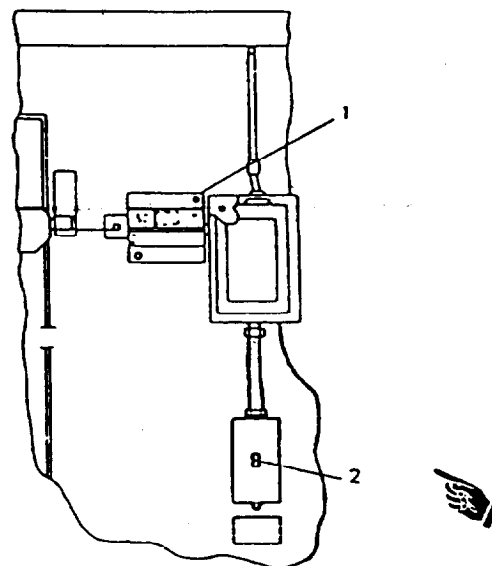

S/N 1089 AND SUBSEQUENT

Section II OPERATOR'S PREVENTIVE MAINTENANCE CHECKS AND SERVICES (PMCS.)

2-4. GENERAL. For the shelter to be ready for use at all times, it must be inspected systematically so that defects may be discovered and corrected before they result in serious damage or failure.

Before you operate. Always keep in mind the CAUTIONS and WARNINGS. Perform your "B-before" PMCS (Table 2-1).

b. While you operate. Always keep in mind the CAUTIONS and WARNINGS. Perform your "D-during" PMCS (Table 2-1).

c. Monthly. Always keep in mind the CAUTIONS and WARNINGS. Perform your "M-monthly" PMCS (Table 2-1).

d. If your equipment fails to operate, troubleshoot with proper equipment. Report deficiencies as follows:

(1) (A) Users report in accordance with DA PAM 738-750.

(2) (P) Users refer to applicable inspection manuals and work card sets in the TO 35C2-3 series for periodic requirements and the PMCS Table for detailed procedures.

2-5. SPECIAL INSTRUCTIONS. The following actions apply while performing your PMCS:

a. Stop operation immediately if deficiency is noted during operation which would damage the equipment.

b. Defects discovered during operation of the equipment should be noted for future correction to be made as soon as operation has ceased.

2-6. PREVENTIVE MAINTENANCE CHECKS AND SERVICES TABLE. Table 2-1 lists all PMCS to be performed by the operator.

NOTE

If the equipment must be kept in continuous operation, check and service only those items that can be checked and serviced without disturbing operation. Make the complete checks and services when the equipment can be shut down. Inspect shelter for leaks.

Table 2-1. Operator's Preventive Maintenance Checks and Services

B - Before

D - During

M - Monthly

Item No.	Interval			Item to be Inspected	Procedures Check for and have re- paired or adjusted as necessary	For Readiness reporting, equipment is Not Ready/ Available if:
	B	D	M			
ELECTRICAL SYSTEM						
1	●	●	●	Circuit breaker panel assembly	Inspect for damage to door and panel	Circuit panel damaged
2	●	●	●	Panel wiring	Inspect for damage or disconnection	Wiring damaged or disconnected
3	●	●	●	Light switches	Inspect for operation	Lights not operating
4	●	●	●	Circuit breakers	Inspect for operation, condition, and security	Circuit breakers not operating
5	●	●	●	Power entry panel assembly	Inspect for damage to panel	Panel damaged
6	●	●	●	Receptacles	Inspect for operation, condition, and security	Receptacles not operating
7	●	●	●	Terminals/Connectors	Inspect for operation, condition, and security	Terminals/connectors not operating
8	●	●	●	Area light assembly	Inspect for operation	Light not operating
9	●	●	●	Incandescent light assembly	Inspect for operation	Light not operating
10	●	●	●	Hinged roof area ceiling lights	Inspect for operation	Lights not operating
11	●	●	●	Fixed roof area ceiling lights	Inspect for operation	Lights not operating
12	●	●	●	Receptacle outlets	Inspect for operation	Outlets not operating

Table 2-1. Operator's Preventive Maintenance Checks and Services (cont)

B - Before

D - During

M - Monthly

Item No.	Interval			Item to be Inspected	Procedures Check for and have re- paired or adjusted as necessary	For Readiness reporting, equipment is Not Ready/ Available if:
	B	D	M			
13	●	●	●	Wall switches	Inspect for operation	Switches not operating
14	●	●	●	Blackout switch	Inspect for operation	Switch not operating
15	●	●	●	Wiring	Inspect for damage or disconnection	Wiring damaged or disconnected
DOOR ASSEMBLIES						
16	●		●	Personnel and right cargo door	Inspect for operation, condition and security	Door not operating, damaged, or insecure
17	●		●	Door vent	Inspect for operation and condition	Vent not operating or damaged
18	●		●	Door lock assembly	Inspect for operation and condition	Lock assembly not operating or damaged
19	●		●	Door stop assembly	Inspect for operation and condition	Stop assembly not operating or damaged
20	●		●	Left cargo door	Inspect for operation condition, and security	Door not operating, damaged, or insecure
21	●		●	Foot bolt assembly	Inspect for operation and condition	Foot bolt assembly not operating or damaged
22	●		●	Chain bolt assembly	Inspect for operation and condition.	Chain bolt assembly not operating or damaged

Table 2-1. Operator's Preventive Maintenance Checks and Services (cont)

B - Before

D - During

M - Monthly

Item No.	Interval			Item to be Inspected	Procedures Check for and have re- paired or adjusted as necessary	For Readiness reporting, equipment is Not Ready/ Available if:
	B	D	M			
	HINGED	PANEL	LEVELING JACK ASSEMBLIES			
23		●	●	Hinged panel leveling jack assemblies	a. Inspect for sinking into ground if shelter not level (check frequently during rainy conditions). b. Inspect for condition and security	a. Shelter not level b. Jacks damaged or insecure
	HINGED	PANEL	ASSEMBLIES			
24		●	●	Hinged roof panels	Inspect skin surface for paint damage, corrosion, cracks, or punctures	Panel skin corroded, cracked, or punctured
25		●	●	Support strut assemblies	Inspect for operation and condition	Support strut assemblies not operating or damaged
26		●	●	Hinged endwall	Inspect skin surface for paint damage, corrosion, cracks, or punctures	Panel skin corroded, cracked, or punctured
27		●	●	Endwall close-out panel	Inspect skin surface for paint damage, corrosion, cracks, or punctures	Panel skin corroded, cracked, or punctured
28		●	●	Latches	Inspect for operation and condition	Latches not operating or damaged
29		●	●	Hinged side-walls	Inspect skin surface for paint damage, corrosion, cracks, or punctures	Panel skin corroded, cracked, or punctured

Table 2-1. Operator's Preventive Maintenance Checks and Services (cont)

B - Before

D - During

M - Monthly

Item No.	Interval			Item to be Inspected	Procedures Check for and have re- paired or adjusted as necessary	For Readiness reporting, equipment is Not Ready/ Available if:
	B	D	M			
30	●		●	Sidewall close-out panels	Inspect skin surface for paint damage, corrosion, cracks, or punctures	Panel skin corroded, cracked, or punctured
31	●		●	ECU intake panel	Inspect skin surface for paint damage, corrosion, cracks, or punctures	Panel skin corroded, cracked, or punctured
32	●		●	ECU return panel	Inspect skin surface for paint damage, corrosion, cracks, or punctures	Panel skin corroded, cracked, or punctured
33	●		●	Hinged floor panel	Inspect skin surface for paint damage, corrosion, cracks, or punctures	Panel skin corroded, cracked, or punctured
CONTAINER LIFT JACK ASSEMBLIES						
34	●	●	●	Container lift jack assemblies	a. Inspect for sinking into ground if shelter not level (check frequently during rainy conditions). b. Inspect for condition and security	a. Shelter not level b. Jacks damaged or insecure
FIXED PANEL ASSEMBLIES						
35	●		●	Personnel door end endwall panel	a. Inspect skin surface for paint damage, corrosion, cracks, or punctures b. Inspect security of upper mobilizer fitting	a. Panel skin corroded, cracked, or punctured b. Upper mobilizer fitting insecure
36	●		●	Level assembly	Inspect for condition and security	Level assembly damaged or insecure

Table 2-1. Operator's Preventive Maintenance Checks and Services (cont)

B - Before

D - During

M - Monthly

Item No.	Interval			Item to be Inspected	Procedures Check for and have re-repaired or adjusted as necessary	For readiness reporting, equipment is Not Ready/ Available if:
	B	D	M			
37	1		1	Folding step	Inspect for condition and security	Folding step damaged or insecure
38	.		1	Cargo door end endwall panel	a. Inspect skin surface for paint damage, corrosion, cracks, or punctures b. Inspect security of upper mobilizer fittings	a. Panel skin corroded, cracked, or punctured b. Upper mobilizer fittings insecure
39	1		1	Roof panel	a. Inspect skin surface for paint damage, corrosion, cracks, or punctures b. Inspect roof hand hold for condition and security c. Inspect strike plates for security and condition	a. Panel skin corroded, cracked, or punctured b. Hand hold damaged or insecure c. Strike plate loose or damaged
40	1		1	Load balancer and cable assembly	Inspect for operation, condition, and security	Load balancer and cable assembly not operating, damaged, or insecure
41	1		1	Stowage brackets	Inspect for condition and security	Stowage brackets damaged or insecure
42	1		1	Solar bar assembly	Inspect for operation, condition, and security	Solar bar assembly not operating, damaged or insecure

Table 2-1. Operator's Preventive Maintenance Checks and Services (cont)

B - Before

D - During

M - Monthly

Item No.	Interval			Item to be Inspected	Procedures Check for and have re- repaired or adjusted as necessary	For readiness reporting, equipment is Not Ready/ Available if:
	B	D	H			
43	●		●	Floor panel	Inspect skin surface for paint damage, corrosion, cracks, or punctures	Panel skin corroded, cracked, or punctured
FRAME ASSEMBLY						
44	●		●	Corner post and ISO fitting assembly	Inspect for condition and security	Corner post or ISO fitting damaged or insecure
45	●		●	Camlock and latch cam handle	Inspect for operation, condition, and security	Camlock or latch cam handle not operating, damaged, or insecure
MISCELLANEOUS COMPONENTS						
46	●		●	Equipment container	Inspect for condition and completeness	Equipment container damaged or incomplete
47	●		●	storm configuration components	Inspect for condition and completeness	Storm configuration components damaged or incomplete
48	1		1	Support braces	Inspect for condition	Support braces damaged
49	●		●	Leveling jack extensions	Inspect for condition	Leveling jack extensions damaged
C A U T I O N						
Skin surfaces that are punctured/damaged will allow water entry into honeycomb panel. All punctures/holes of damaged areas must be covered immediately pending permanent repair.						

Section III. SETUP OF SHELTER

2-7. PREPARATION FOR USE.

Select a site that:

- Has reasonable maneuvering area for vehicles that will be used for hauling or hoisting shelter.
- The terrain is firm, well drained, and relatively free of surface rocks or stones.
- The slope of the terrain does not exceed 18 inches (45.7 cm) over the projected floor area of the expanded shelter.

2-8. SHELTER INVENTORY CHECKS.

a. Expandable shelters are shipped uncrated.

b. Inspect shelter for damage incurred during shipment. If shelter has been damaged, report damage on SF361, Transportation Discrepancy Report.

Check equipment against packing list to see if shipment is complete. Report all discrepancies in accordance with instructions of DA PAM 738-750.

d. Inspect shelter (stowed mode) in accordance with paragraph 2-9.

2-9. SHELTER INSPECTION CHECKLIST

LOCATION	ITEM	ACTION
1. Fixed personnel endwall	a. Power entry panel	Inspect connectors for damage.
	b. Identification and instruction plates	Check for legibility or missing plates.
	co Personnel door	Check for security and condition of door, locks, seals, and vent.

2-9. (cont)

LOCATION	ITEM	ACTION
	d. Upper mobilizer fittings	Check for security and condition.
	e. Folding steps	Check for security and condition.
	f. Components	Inspect for missing, bent, or damaged components.
	g. Skin	Inspect skin surface for paint damage, corrosion, cracks, or punctures.
2. Fixed roof	a. Roof handhold	Check for security and operation.
	b. Upper ISO fittings	Inspect fittings for damage.
	c. Skin	Inspect skin surface for paint damage, corrosion, cracks, or punctures.
	d. Strike plates	Check for security and condition.
3. Fixed cargo endwall	a. CSC Plate	Check for legibility or missing plate.
	b. Doors	Check for security and condition of doors, locks, seals, and vents.
	c. Upper mobilizer fittings	Check for security and condition.
	d. Components	Inspect for missing, bent, or damaged components.
	e. Skin	Inspect skin surface for paint damage, corrosion, cracks, or punctures.
4. Hinged floors	Skin	Inspect skin surface for paint damage, corrosion, cracks, or punctures.

2-9. (cont)

	LOCATION	ITEM	ACTION
5.	Fixed floor base frame	a. Lower mobilizer fittings b. Lower ISO fittings c. Frame edge and fork lift opening	Check for security and condition. Inspect fittings for damage. Inspect for damage.
6.	Corner posts	Components	Inspect for missing, bent, or damaged components.

2-10. SHELTER HANDLING

WARNING

Do not use handling equipment with capacity of less than gross weight of system. Do not allow shelter to swing back and forth when suspended. Failure to observe this WARNING may result in damage to equipment or severe injury or death to personnel.

NOTE

Dollyset M832 mobilizer used only if gross weight of shelter system is 10,000 pounds (4546 Kg) or less.

Dollyset XM1022 or hoisting sling (with cable breaking strength of 35,000 pounds) used if gross weight of shelter system is over 10,000 pounds (4546 kg).

When using fork lift, make sure it has a minimum tine length of six feet. Use inner slots for fork lifting an empty shelter only.

Use 20-foot container lift sling (bottom lift, type II, with a 20 long ton safe working load) with aluminum spreader, Appendix D.

2-10. (cont)

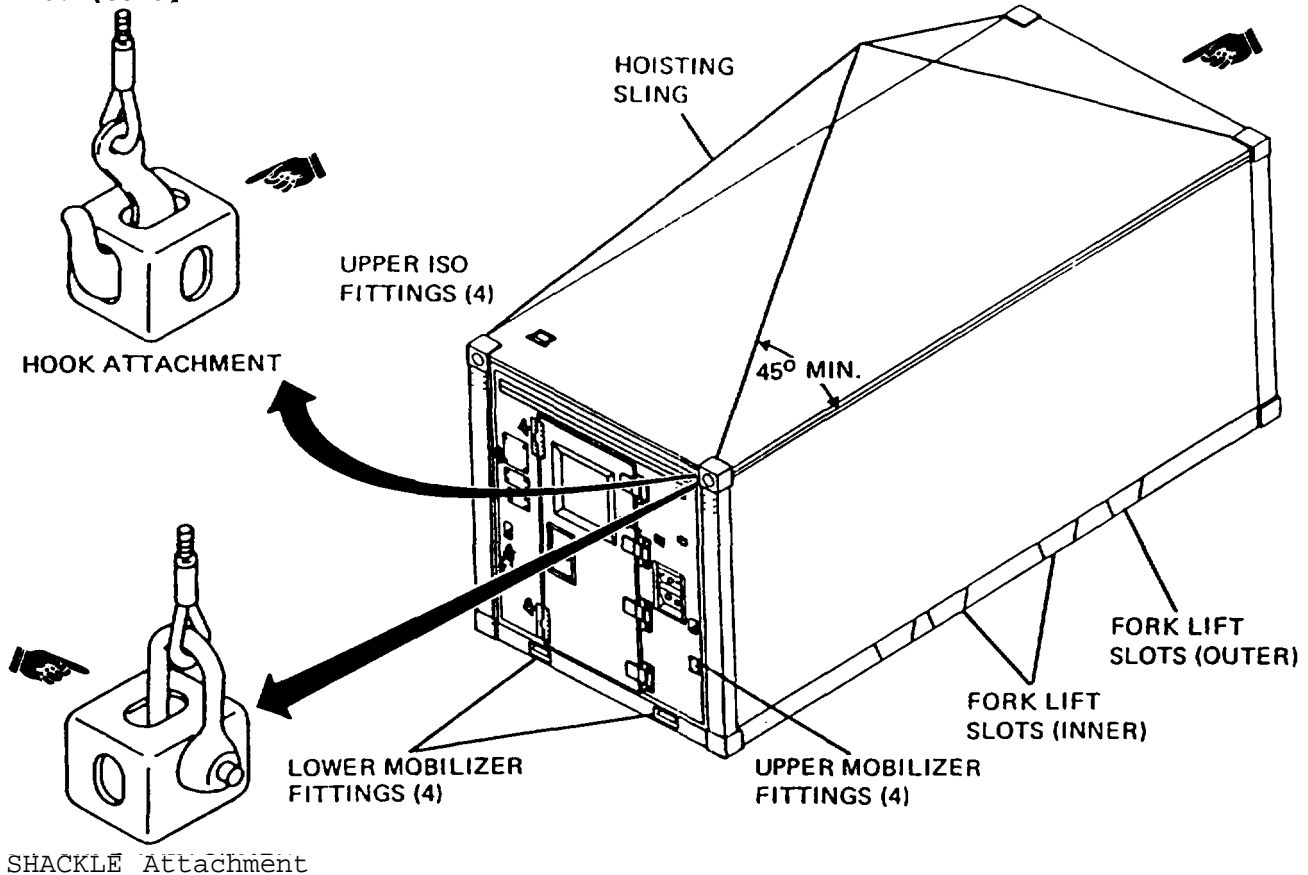

- a. Hoisting from upper ISO fittings.

CAUTION

Do not attach hoisting sling or ISO lifting device to handling equipment in such a manner that angle between hoist line and shelter is less than 45 degrees. Any angle less than 45 degrees will cause an excessive strain which could damage shelter.

(1) Attach hoisting sling to crane or equivalent and four upper ISO fittings.

(2) Hoist shelter and position to desired location.

- b. Hoisting from lower ISO fittings.

(1) Attach ISO lifting device to crane or equivalent and four lower ISO fittings.

(2) The ISO lifting device should contact four lower ISO fittings only and not make any other contact with shelter.

2-10, (cont)

(3) Terminal fittings shall be installed so that lifting forces are exerted not more than 1-1/2 in. (38 mm) away from ISO fittings.

(4) Hoist shelter and position to desired location.

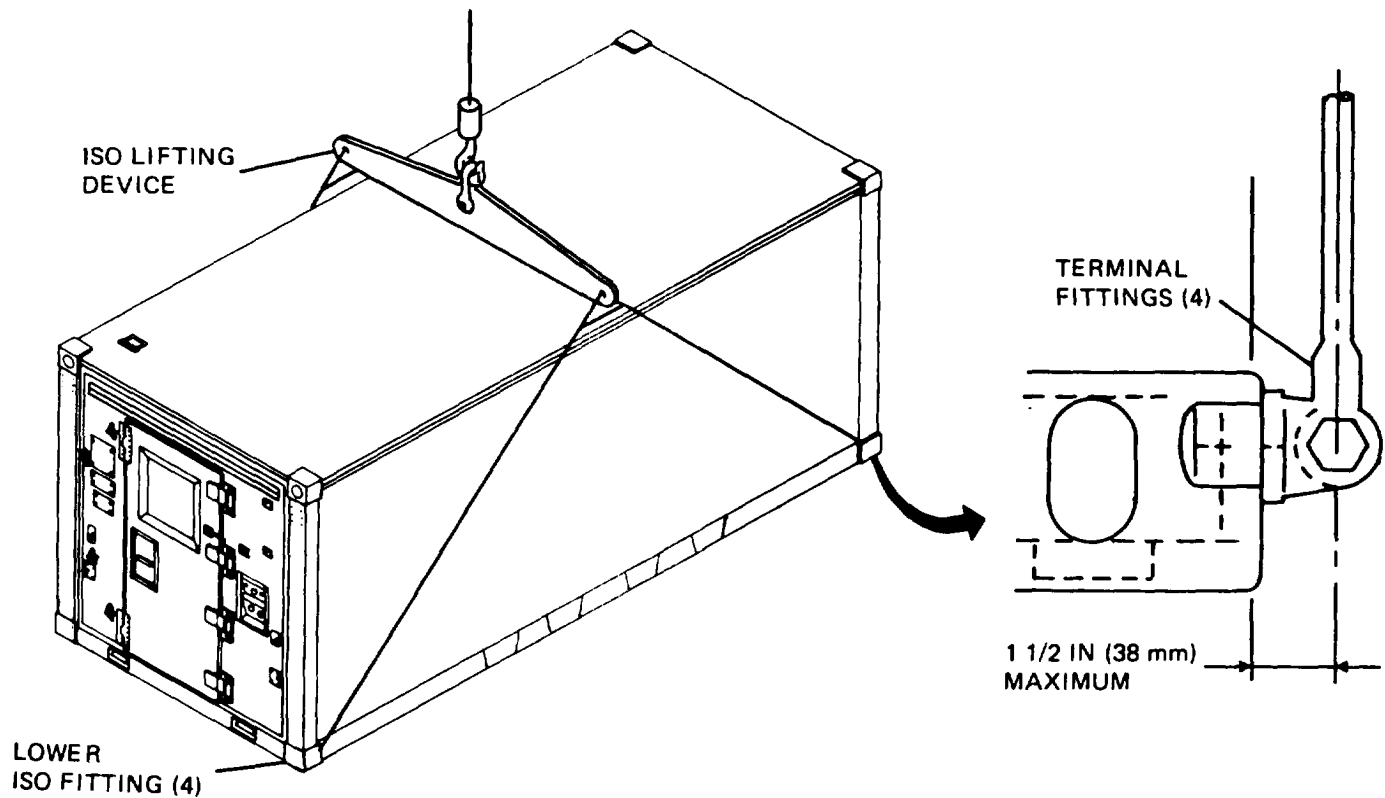

c. Fork lifting from fork lift slots in base frame.

- (1) Fork lift arms shall be at least 6 ft (1.8 m) long.
- (2) Use care when inserting fork lift arms in fork lift slots.
- (3) Use inner slots for fork lifting an empty shelter only.
- (4) Use outer slots for fork lifting shelter with maximum payload.

d. Dollyset lifting from mobilizer fittings.

(1) Separate Dollyset sections and prepare for use observing all recommendations of Dollyset technical manual.

(2) Position. Dollyset sections at ends of shelter adjacent to mobilizer fittings at shelter endwalls.

(3) Position Dollyset brackets to connect with shelter mobilizer fittings and secure Dollyset to shelter.

2-10. (cont)

(4) Operate Dollyset according to Dollyset technical manual to raise shelter to towing height.

(5) Connect towing equipment to Dollyset tow bar.

(6) When shelter is in desired position, operate Dollyset to lower shelter and remove Dollyset sections.

e. Dollyset lifting from ISO fittings.

(1) Separate Dollyset sections and prepare for use observing all recommendations of Dollyset technical manual.

(2) Position Dollyset sections at ends of shelter adjacent to ISO fittings at shelter endwalls.

(3) Position Dollyset brackets to connect with shelter ISO fittings and secure Dollyset to shelter.

(4) Operate Dollyset according to Dollyset technical manual to raise shelter to towing height.

(5) Connect towing equipment to Dollyset tow bar.

(6) When shelter is in desired position, operate Dollyset to lower shelter and remove Dollyset sections.

f. Trailer or flatbed transporting.

(1) Using four 14-foot chains and four binders, secure shelter to trailer or flatbed as shown in method 1.

(2) Using two 20-foot chains and two binders or four 6-foot chains and two binders, secure shelter to trailer or flatbed as shown in method 2.

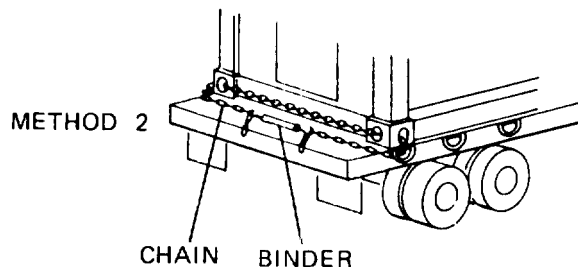
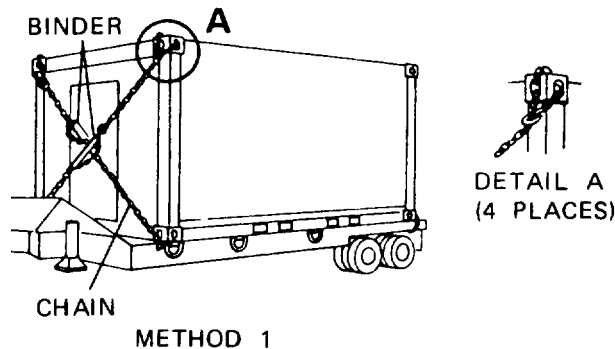

2-10. (cont)

g. Railroad transporting.

(1) Place floor timbers along the front and rear of the shelter contacting lower ISO fittings.

NOTE

Make sure timber is new and has no structural weakness.

(2) Tie the shelter down to the retaining brackets on the railroad car with 1/2-inch diameter wire rope and turn buckles.

(3) Place 8 inch by 8 inch blocking timbers on the railroad car floor with the edge grain laid flatwise.

(4) Place at least four 4 inch by 5 inch vertical post timbers with edge grain oriented fore and aft at each end of the shelter.

(5) Bolt the ends of the floor timbers to the vertical post timbers using 3/4-inch diameter bolts.

(6) Spike or nail the vertical post timbers through the retaining brackets on the railroad car to prevent vertical movement.

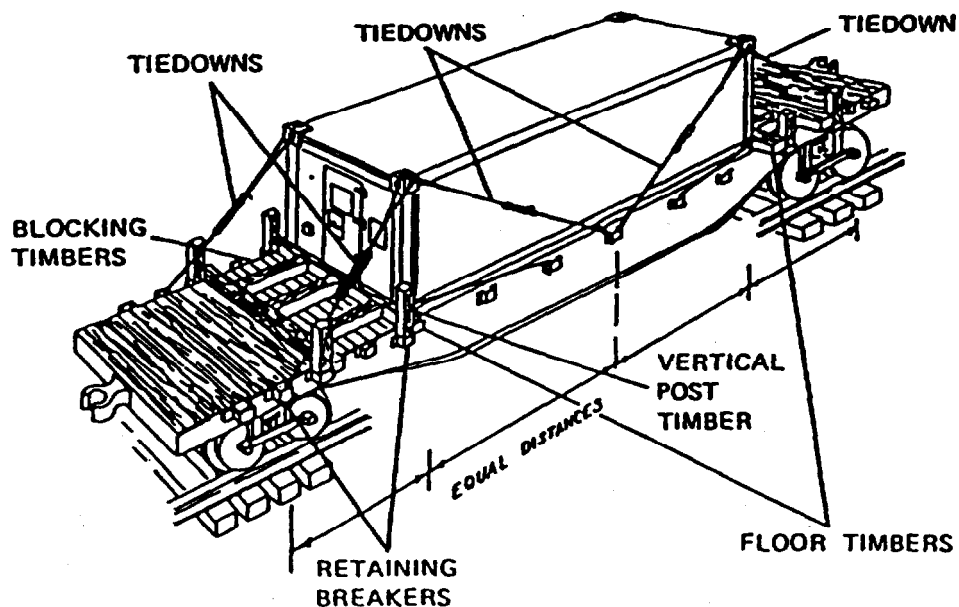

2-11. LOCATION OF IDENTIFICATION AND INSTRUCTION PLATES. The following figures provide location and contents of identification and instruction plates for the shelter.

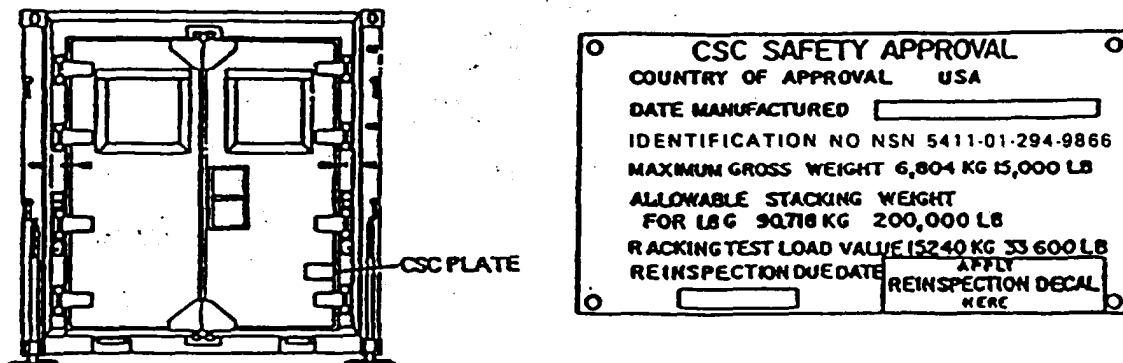
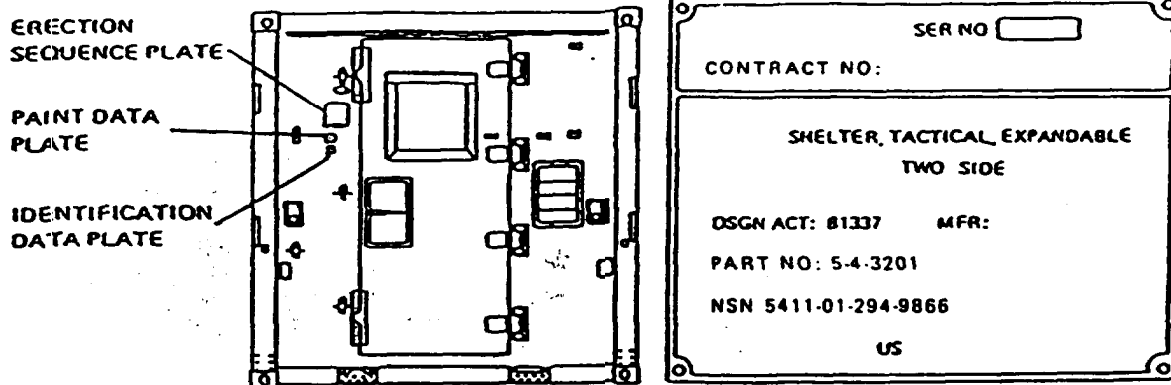
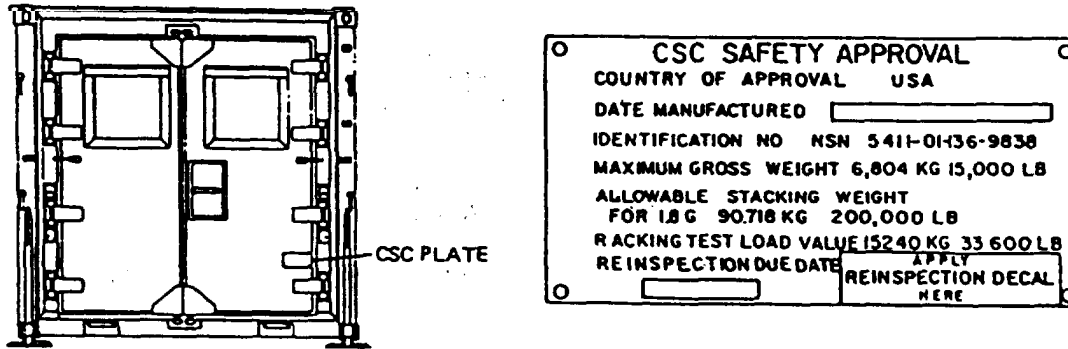
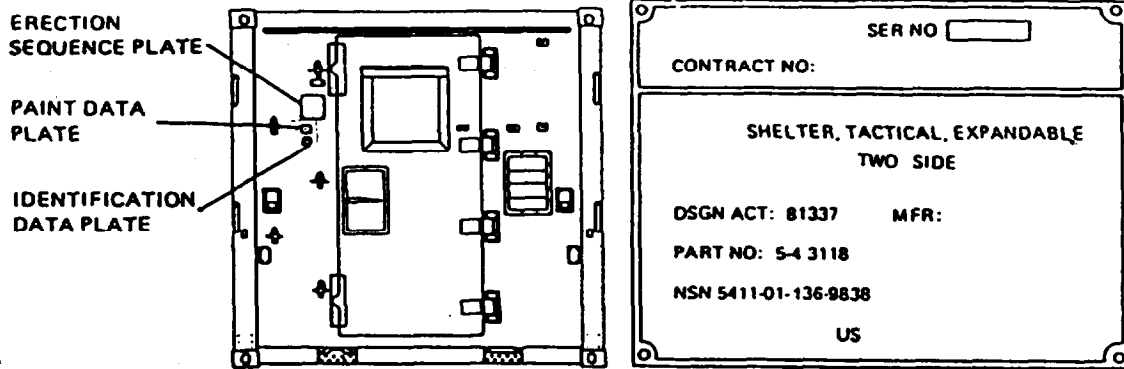

2-11. LOCATION OF IDENTIFICATION AND INSTRUCTION PLATES. (Cont)

Sand Paint Data Plate (with scuff strip)

THIS SHELTER PAINTED WITH CARC PAINT			
	PAINT TYPE	MIL SPEC COLOR	COLOR CODE FED-STD-595
INTERIOR PAINT	EPOXY	MIL-C-22750 WHITE	17925
EXTERIOR PAINT	ALIPHATIC POLYURETHANE	MIL-C-46168 SAND	33303
PRIMER	EPOXY	MIL-P-53022	
FLOOR PAINT	WALKWAY COMPOUND	MIL-W-5044 TYPE I GRAY	26251
FLOOR PAINT	WALKWAY COMPOUND	MIL-W-5044 TYPE II GRAY	26251

Location of Identification and Instruction Plates

Sand Paint Data Plate (without scuff strip)

THIS SHELTER PAINTED WITH CARC PAINT			
	PAINT TYPE	MIL SPEC COLOR	COLOR CODE FED-STD-595
INTERIOR PAINT	EPOXY	MIL-C-22750 WHITE	17925
EXTERIOR PAINT	ALIPHATIC POLYURETHANE	MIL-C-46168 SAND	33303
PRIMER	EPOXY	MIL-P-53022	
FLOOR PAINT	WALKWAY COMPOUND	MIL-W-5044 TYPE I GRAY	26251

Location of Identification and Instruction Plates

2-11. LOCATION OF IDENTIFICATION AND INSTRUCTION PLATES. (Cont)

Camouflage Paint Data Plate (with scuff strip)

THIS SHELTER PAINTED WITH CARC PAINT			
	PAINT TYPE	MIL SPEC COLOR	COLOR CODE FED-STD-595
INTERIOR PAINT	EPOXY	MIL-G22750 GLOSS WHITE	17925
EXTERIOR PAINT	ALIPHATIC POLYURETHANE	MIL-C-46168 GREEN 383 BROWN 383 BLACK	34094 30051 37030
PRIMER	EPOXY	MIL-P-53022	
FLOOR PAINT	WALKWAY COMPOUND	MIL-W-5044 TYPE I GRAY	26251
FLOOR PAINT	WALKWAY COMPOUND	MIL-W-5044 TYPE II GRAY	26251

Camouflage Paint Date Plate (without scuff strip)

THIS SHELTER PAINTED WITH CARC PAINT			
	PAINT TYPE	MIL SPEC COLOR	COLOR CODE FED-STD-595
INTERIOR PAINT-ILL	EPOXY	MIL-C-22750 WHITE	17925
EXTERIOR PAINT	ALIPHATIC POLYURETHANE	MIL-C-46168 GREEN 383 BROWN 383 BLACK	34094 30051 37030
PRIMER	EPOXY	MIL-P-53022	
FLOOR PAINT	WALKWAY COMPOUND	MIL-00-5044 TYPE I GRAY	26251

2-11. LOCATION OF IDENTIFICATION AND INSTRUCTION PLATES. (Cont)

Green Paint Data Plate (with scuff strip)

THIS SHELTER PAINTED WITH CARC PAINT			
	PAINT TYPE	MIL SPEC COLOR	COLOR CODE FED-STD-595
INTERIOR PAINT	EPOXY	MIL-C-22750 WHITE	17925
EXTERIOR PAINT	ALIPHATIC POLYURETHANE	MIL-C-46168 GREEN 383	34094
PRIMER	EPOXY	MIL-P-53022	
FLOOR PAINT	WALKWAY COMPOUND	MIL-W-5044 TYPE I GRAY	26251
FLOOR PAINT	WALKWAY COMPOUND	MIL-W-5044 NPE II GRAY	26251

Green Paint Data Plate (without scuff strip)

THIS SHELTER PAINTED WITH CARC PAINT			
	PAINT TYPE	MIL SPEC COLOR	COLOR CODE FED-STD-595
INTERIOR PAINT	EPOXY	MIL-C-22750 WHITE	17925
EXTERIOR PAINT	ALIPHATIC POLYURETHANE	MIL-C-46168 GREEN 383	34094
PRIMER	EPOXY	MIL-P-53022 TYPE I	
FLOOR PAINT	WALKWAY COMPOUND	MIL-W-5044 TYPE I GRAY	26251

2-11. (cont)

ERECTION SEQUENCE

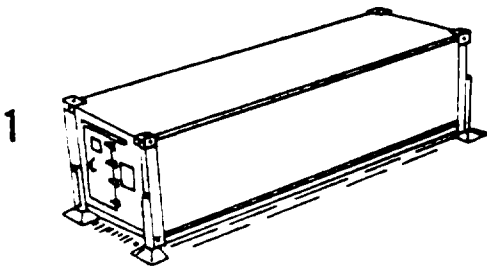

1
THE SHELTER JACKS ARE REMOVED FROM THEIR STOWED LOCATION AND ATTACHED TO THE FOUR CORNERS OF THE MODULE.
THE MODULE IS LEVELED USING THE 'BULL'S EYE' LEVELS LOCATED NEAR THE JACKS.

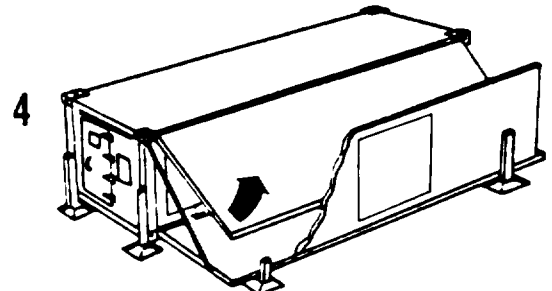

4
SLIDE THE HINGED-ROOF OUTWARD WITH SOLAR BAR
RAISE PARTIALLY TO PROVIDE ACCESS TO THE ROOF STRUTS STOWED ON THE INSIDE OF THE HINGED ROOF
LOWER AND PIN ROOF STRUTS

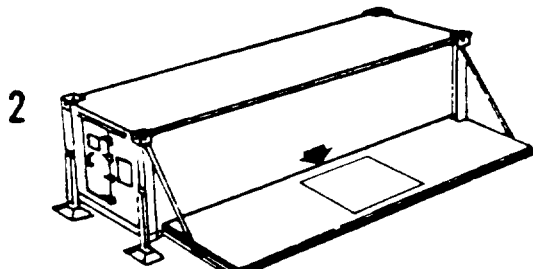

2
REMOVE CABLE RETAINING PINS INSIDE SHELTER. DISENGAGE EXTERNAL FLOOR LOCKS AND USE LOCKING MECHANISM TO FREE FLOOR ENGAGEMENT
LOWER THE FLOOR TO THE EXTENT OF THE CABLE TRAVEL (1 1/2" BELOW LEVELS)

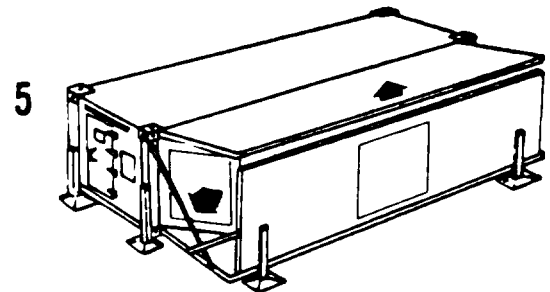

5
RAISE THE HINGED ROOF AND REST ON ROOF STRUT!
SWING THE HINGED ENDWALLS OUT TO THE OPEN POSITION

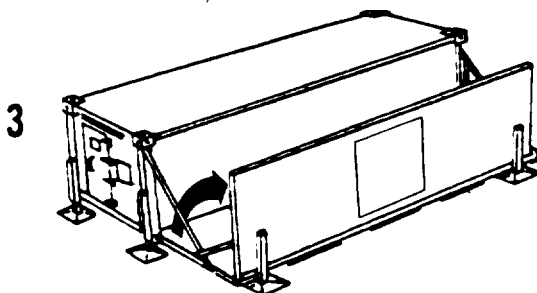

3
RAISE THE HINGED SIDEWALL AND CONNECT 2 SUPPORT BRACES.
INSTALL 2 SUPPORT JACKS.

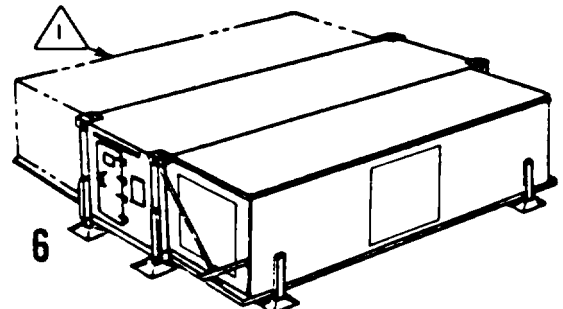

6
USING THE SUPPORT JACKS, RAISE THE HINGED FLOOR AND SIDEWALL TO MATE THE HINGED ENDWALLS. LINE UP POSITIONING MARKS.
REMOVE THE STRUTS FROM THE UPRIGHT POSITION ALLOWING THE HINGED ROOF TO REST ON THE HINGED SIDEWALL AND ENDWALLS
STOW THE STRUTS ON THE HINGED ROOF, ENGAGE ALL PANEL LATCHES TO COMPRESS THE SEALS.

 REPEAT SEQUENCE FOR OPPOSITE SIDE.

2-12. SHELTER EXPANSION

NOTE

Four personnel are required to perform the following procedures.

- a. Remove four container lift jacks from inside of personnel and right cargo doors by turning locking handle to loosen jack attachment insert and removing safety pin.
- b. Position jacks at each corner of shelter.

NOTE

Stencil on jack indicates handle rotation to raise or lower jack.

- c. Rotate handle to raise jack until insert will enter lower ISO fitting and upper jack attachment engages jack support bracket on corner post.
- d. Turn locking handle to rotate insert in ISO fitting. Install safety pin.
- e. Repeat steps c and d at three remaining corner posts.

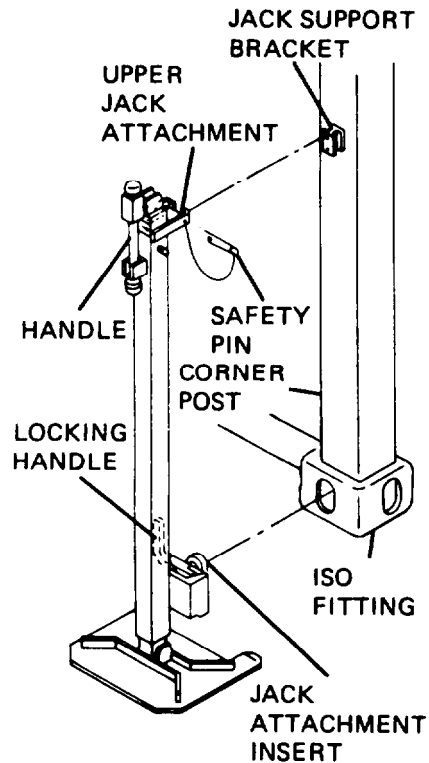
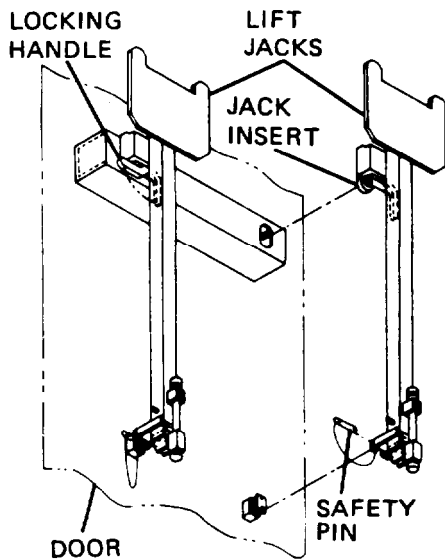

2-12. (cont)

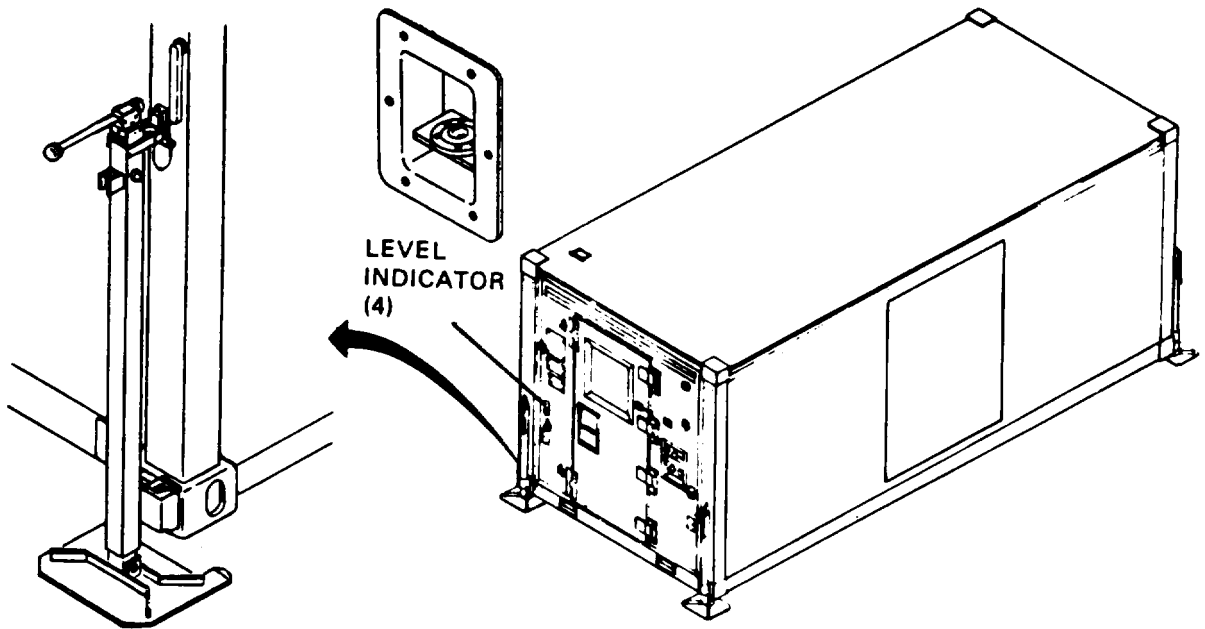

f. Raise all jacks simultaneously at each corner of shelter to prevent excessive strain on jacks or shelter.

NOTE

The shelter shall be raised a minimum of 3 inches (7.6 cm) off ground.

g. Watch level indicators at each corner and adjust jacks as needed in order to level shelter.

h. Remove quick release pins from stop plates on both load balancers (inside shelter) of the side of the shelter being expanded to permit support cable travel.

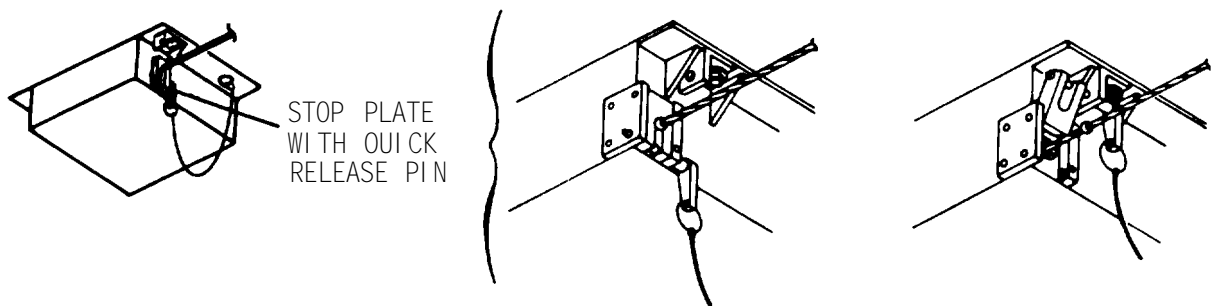

2-12. (cont)

WARNING

Expandable section (hinged floor and hinged sidewall together) weighs 700 pounds (318 kg). Do not stand directly in front of hinged section.

i. Raise cam lock handles on corner posts and rotate as indicated to disengage hinged floor locks.

Carefully lower hinged floor to the extent of support cable travel (1-1/2 in. (3.8 cm) below level).

WARNING

The stop plate cable assembly is a spring powered mechanism. Personal injury or death may result if two quick release pins are not installed in the stop plates.

k. Install two quick release pins in stop plates on load balancers (inside shelter) to prevent return of support cable.

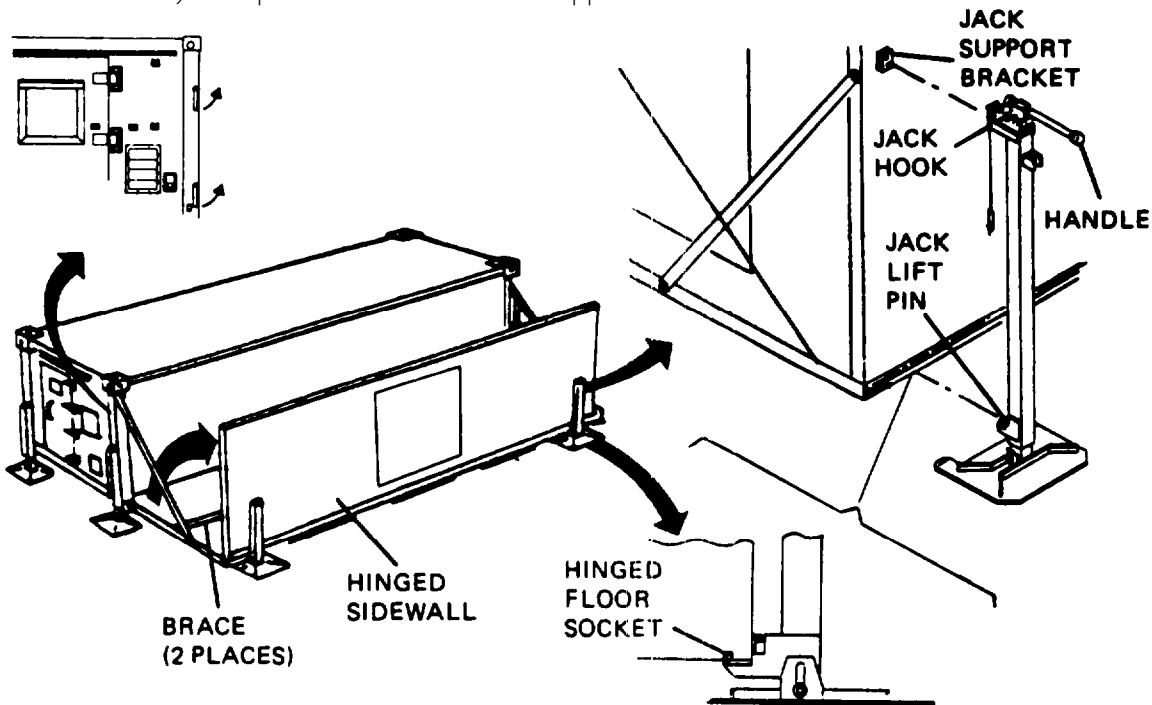

l. Remove two support braces from equipment container.

m. Raise hinged sidewall and hold in position.

n. Install the two support braces in brace cups on hinged floor and sidewall behind support cable.

o. Remove two leveling jacks from inside of left cargo door.

p. Position jacks at each corner of expanded side.

2-12. (cont)

NOTE

Stencil on jack indicates handle rotation to raise or lower jack.

q. Rotate handle to raise jack until jack lift pin engages hinged floor socket and jack hook engages jack support bracket on hinged sidewall.

NOTE

If side jacks are not high enough, perform step r.

r. Remove two jack extensions from equipment container and install between jack base and upper section of jack.

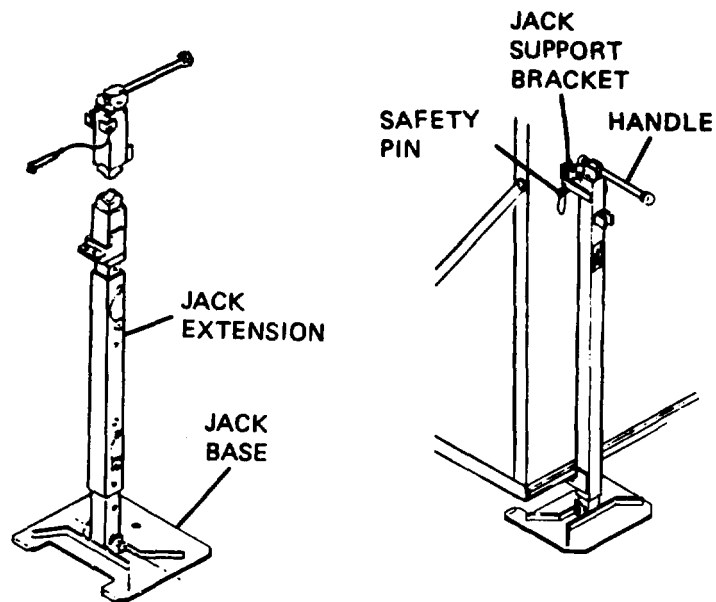

s. Rotate handle to raise jack until safety pin can be installed in jack support bracket.

NOTE

Do not attempt to level or raise floor at this time.

2-12. (cont)

WARNING

Door vents are spring loaded to swing upward. To prevent injury, hold door vent shut while unlatching all the retaining clips.

2-12. (cont)

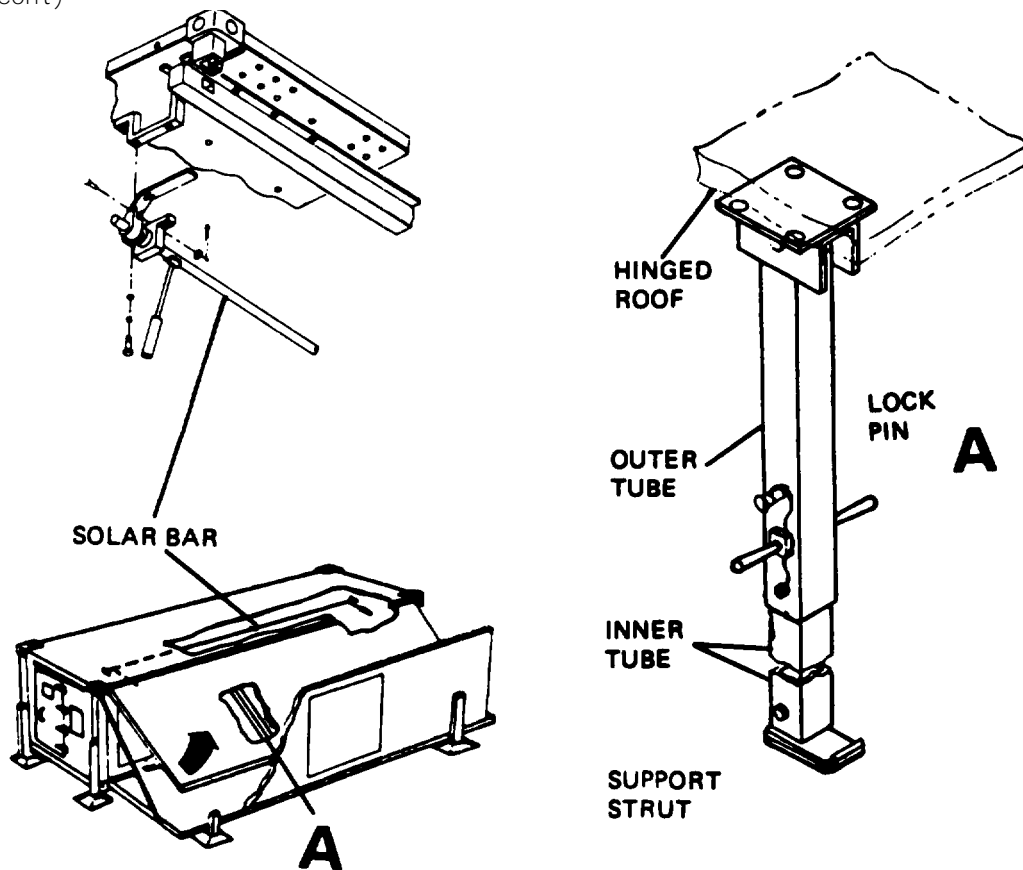

t. Push two handles of solar bar on inside of fixed roof to their extent simultaneously to slide hinged roof outward,

C A U T I O N

Support inner tube while disengaging support struts from stowage brackets.

u. Pull lock pin to free support struts from stowage bracket and swing downward,

2-12. (cont)

v. Extend inner tube of strut and insert lock pin when pin holes in inner tube and outer tube are in alignment.

C A U T I O N

Do not force hinged roof to full height. This could cause damage to the roof and sidewall seal. Ensure that the hinged roof will clear the hinged sidewall prior to lifting.

w. Raise hinged roof to full height of struts using all four personnel: Two on support struts; two to assist at roof.

2-12. (cont)

- x. Swing hinged endwalls out to open position.
- y. Rotate handles to raise both jacks until positioning marks on hinged endwalls and hinged sidewall are in alignment.

CAUTION

Do not continue to jack since this may cause structural damage to hinged endwall.

- z. Use support struts to lower hinged roof to rest on hinged endwalls and sidewall.

- aa. Remove lock pins from support struts. Compress support struts and secure in storage brackets on hinged roof with lock pins.

- ab. Adjust leveling jack to make sure positioning marks on hinged roof and hinged sidewall are properly aligned.

- ac. Obtain four removable latches from equipment container and install two on hinged sidewall and two on hinged endwalls.

- ad. Engage all panel latches to compress seals. Engage nonremovable latches first then removable latches.

- ae. Visually check to make sure all seals are properly compressed.

- af. Remove support braces.

- ag. Repeat steps h through af to extend other expandable side, then stow support braces in equipment container.

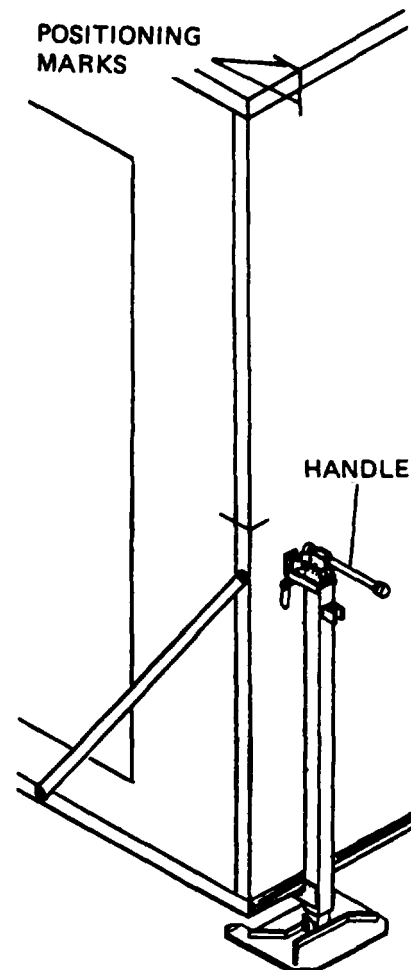

2-13. CEILING LIGHTS AND UTILITY OUTLETS INSTALLATION

a. Ceiling light installation.

WARNING

In the event of lamp breakage, care must be taken in removal of broken glass fragments and white phosphorous dust that may be dispersed within fixture. Inhalation of phosphorous dust could cause dangerous injury.

- (1) Set circuit breaker CB6 to "off" position.
- (2) Remove power cord from stowage clip on ceiling.
- (3) Depress plunger lock in fixed roof light stowage bracket.
- (4) Move entire light fixture lengthwise toward power cord end to disengage light from the four captive studs in fixed roof.
- (5) Move light fixture into expandable section and mate with four captive studs in hinged roof.

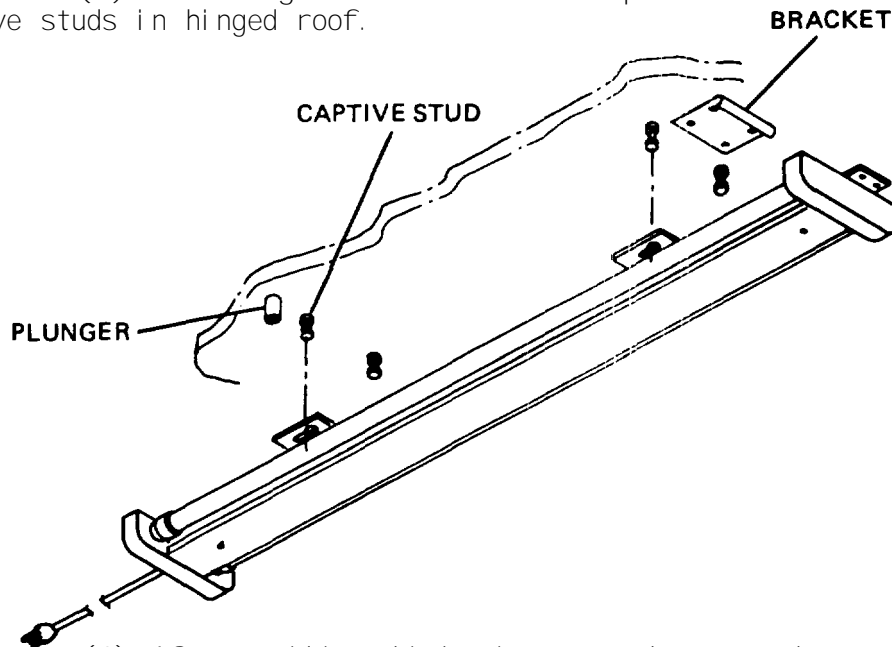

- (6) After ceiling light is properly seated, secure fixture by moving until spring loaded plunger engages.
- (7) Plug power cord into connector, and twist one-quarter turn to lock in.
- (8) Repeat this procedure for each of five remaining ceiling lights.

b. Cable and receptacle assembly installation.

2-13. (cont)

(1) Release captive fasteners and reposition receptacles from stowed position on hinged endwall to operating position on hinged endwalls and hinged sidewalls.

(2) Position receptacles with power cords facing up.

(3) Secure flexible cable with velcro straps.

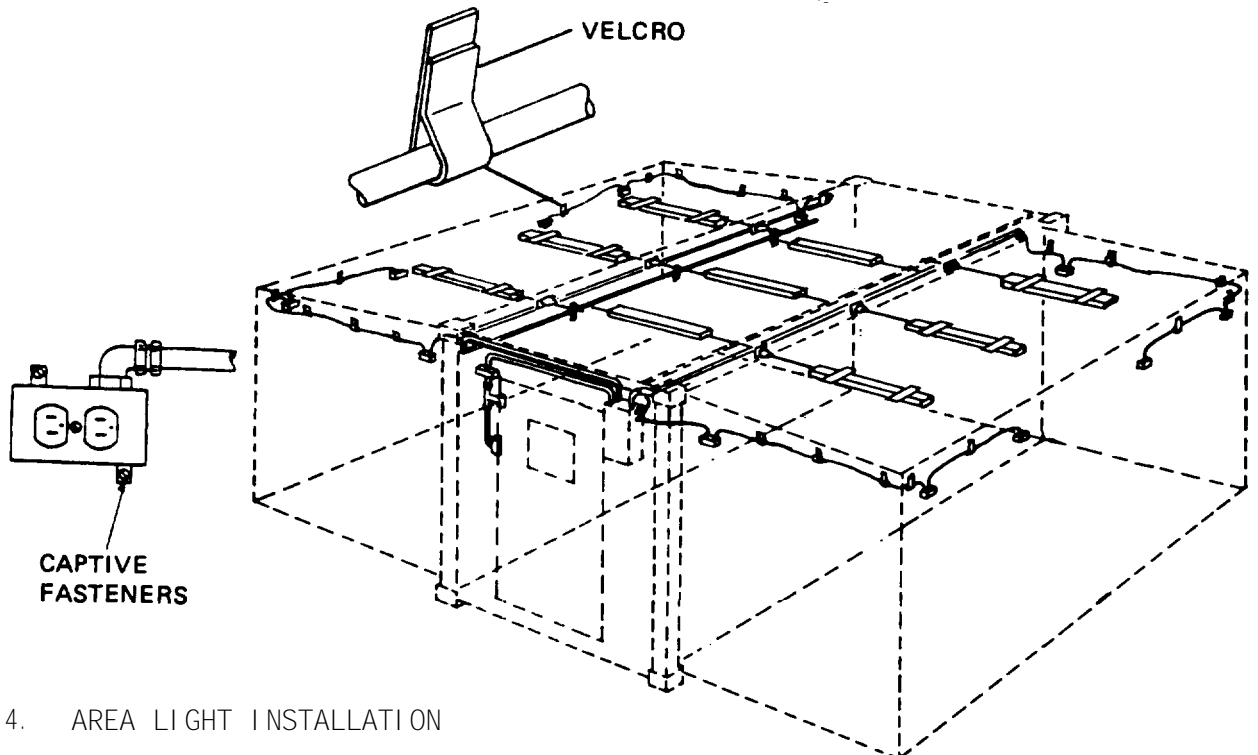

2-14. AREA LIGHT INSTALLATION

a. Loosen wingnuts and remove area light from stowage location inside shelter on personnel end panel.

NOTE

Do not remove wingnuts from screws.

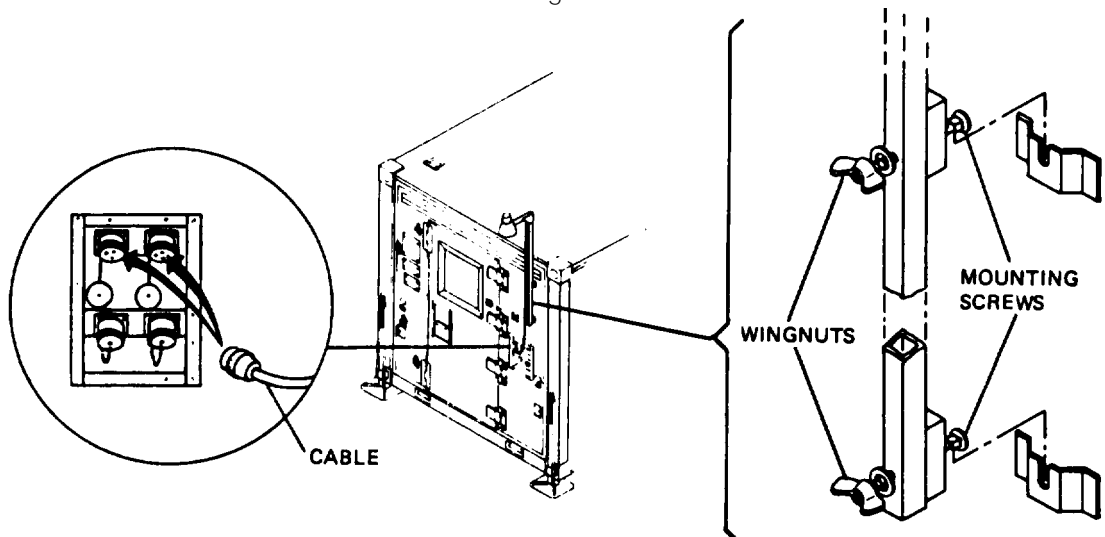

2-14. (cont)

- b. Remove bulb from equipment container and screw bulb into light socket.
- c. Install the area light on the fixed personnel or cargo endwall by mating the headed end of the mounting screws with the brackets provided.
- d. Secure the area light to the mounting brackets by tightening the two wingnuts.

NOTE

When the area light is installed at cargo end of shelter the cable is routed over the top of the shelter. The excess cable slack should be neatly coiled on the area light post so that it does not present a hazard to personnel.

- e. Connect cable into J3 or J4 connectors on the power entry panel.

2-15. EXTERNAL CONNECTIONS.

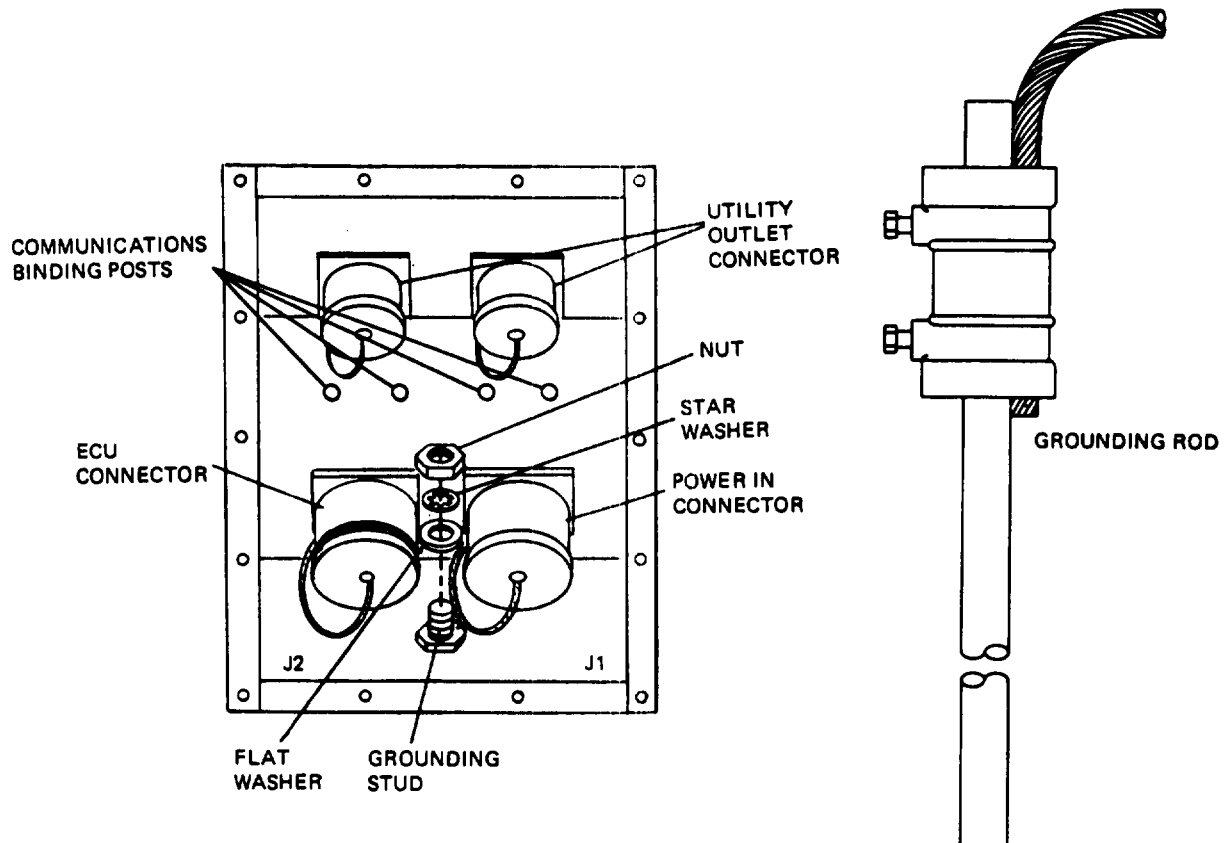

2-15. (cont)

a. Shelter grounding

NOTE

Shelter is grounded through externally connected power supply. Additional grounding, depending on local conditions, may be installed by utilizing optional grounding rod, Appendix D. Consult a qualified electrician for proper grounding procedures required for surrounding soil conditions.

(1) Drive ground rod into earth at a suitable location that permits ground cable attached to rod to reach ground stud on power entry panel.

(2) On power entry panel remove nut, star washer, and flat washer on stud.

(3) Connect ground cable connector to stud and secure with washer, star washer, and nut.

(4) Check all connections for security.

b. Input power connection

W A R N I N G

Do not attempt connection of live line to power entry panel. Deactivate power source or generator before procedure.

C A U T I O N

Power supply shall be 120/208 Vac, 4 wire with 1 ground for Model NQ0B Circuit Breaker Panel or 120/208 Vac, 4 wire with 4 grounds for Model NQ0D Circuit Breaker Panel or damage to equipment will result.

(1) Turn all circuit breakers to OFF position,

NOTE

Make certain that power entry panel and power supply cable are terminated with same type of connector.

(2) Connect power supply cable to power entry panel at connector (J1).

2-15. (cont)

(3) Turn MAIN circuit breaker to ON position and observe any unusual conditions.

(4) Turn remaining circuit breakers to ON position one at a time and observe any-unusual conditions.

c. ECU Connection.

(1) Turn CB1 to OFF position.

(2) Connect ECU supply cable to connector (J2).

(3) Turn CB1 to ON position and observe for any unusual conditions.

2-16. CLOSING SEQUENCE

NOTE

Four personnel are required to perform the following procedures.

Make sure hinged floor is clear of items or debris and floor hinges are clean of sand or dirt.

Make sure top of hinged roof is clear of items, debris, snow, or ice and hinged floor extension is clear of foreign matter, snow or ice.

Do not attempt to lower or remove container lift jacks until after procedures in steps a through q have been completed.

- a. Remove power cord from power entry panel.
- b. Remove ECU intake and return panels and replace with closeout panels.
- c. Remove hinged roof area ceiling lights and receptacles from expanded section and return to their stowage position.
- d. Remove and stow latch plates in equipment container.

2-16. (cont)

WARNING

It is essential that the complete latch is pressed flat into the pan.

- e. Release all latches between hinged sidewall, endwall, roof, and floor.
- f. Lower support struts and raise hinged roof to full extent of strut.
- g. Disengage quick release pin and stop plate for cable on load balancer.
- h. Lower hinged floor with leveling jacks.
- i. Fold in hinged endwall to roof beam and hold in place with velcro straps.
- j. Lower hinged roof by using support struts and personnel at each end of roof.
- k. Slide hinged roof inward to stowage position by pulling down on solar bar handles.
- l. Remove leveling jacks supporting hinged floor and stow on left cargo door.
- m. Remove sidewall support braces and store in equipment container.

WARNING

To avoid injury, be careful not to get caught between cable and sidewall panel. Do not attempt to control panel if it is accidentally dropped.

- n. Fold down hinged sidewall onto hinged floor. Allow wall to free fall before it comes to the same plane as the cables. Trapped air acts as a cushion.
- o. Position camlocks so handles are vertical and outward.

Raise hinged floor and camlock to corner post. Engage lower locks first. Make sure pins are in holes,

2-16. (cont)

NOTE

If hinged floor and corner post bind, relevel shelter.

- q. Close cargo doors.
- r. Remove container lift jacks and stow on personnel and right cargo doors.

NOTE

If it is intended to use a dollyset to move shelter, place pieces of 4x4 lumber under the frame and clear of the ISO fittings to facilitate mounting of the dollyset.

- s. Stow power cable inside shelter.
- t. Check security of shelter. Quick release pins must be inserted in stop plates on load balancer. Place padlocks on outside door handles.

Section IV. OPERATION UNDER USUAL CONDITIONS

NOTE

If equipment fails to operate, refer to troubleshooting procedures in Chapter 3.

2-17. OPERATING INSTRUCTIONS. Due to the limited operating capability of shelter, operating instructions are limited to operation of circuit breakers and switches for the purpose of providing power to lights, outlets, and externally connected environmental control unit (ECU), if installed. Expanding the shelter and closing the shelter includes maintaining the shelter when performing any PMCS exercise "During" functions.

Section V. OPERATION UNDER UNUSUAL CONDITIONS

2-18. GENERAL . This section provides instructions for operation of the shelter in unusual weather conditions. Operation during blackout conditions is also provided.

2-19. OPERATION IN RAIN AND/OR MUD

- a. Provide adequate drainage ditch to prevent standing water around shelter area.
- b. Check leveling jacks frequently for sinking; level shelter as required by adjusting container lift jacks.
- c. Close and secure all doors in shelter.
- d. Check seals for proper placement and compression.

2-20. OPERATION IN SNOW, ICE OR EXTREME COLD

WARNING

In extreme cold, do not touch metal parts with bare hands. Severe skin damage may result.

- a. Remove snow routinely and prior to folding roof with a soft bristle brush, broom, or equivalent.
- b. Remove ice from shelter before lowering hinged panels.
- c. Insure ECU is properly connected to shelter.
- d. Keep all doors and vents closed.

NOTE

Fluorescent lights have a delay time in coming on at temperatures of 0°F and below.

2-21. OPERATION IN HIGH WINDS.

WARNING

To avoid injury when expanding or closing hinged sidewall in high winds, use six personnel.

NOTE

Two personnel are required to perform the following procedure.

To install the storm configuration (tie-down installation) kit, use the following items.

- (1) Ground anchor assembly.
- (2) Driving rod.
- (3) Holding handle.
- (4) Driving head.
- (5) Tie-down ring.

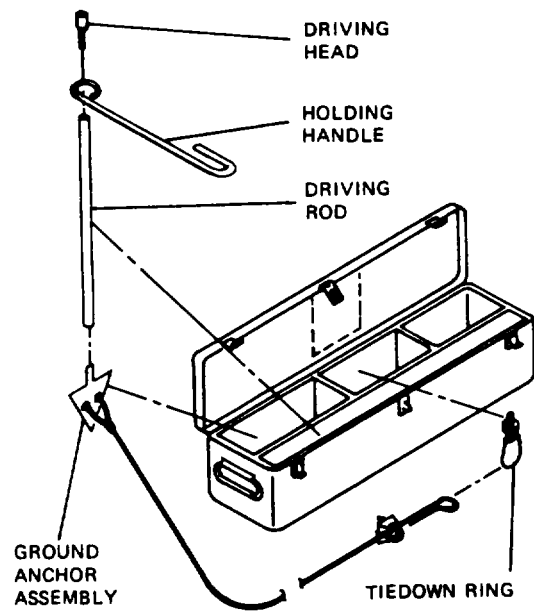

WARNING

Safety glasses must be worn by personnel when installing ground anchors.

- b. One person shall support driving rod with holding handle, while second person drives ground anchor into ground using 12-pound sledge hammer, Appendix D.

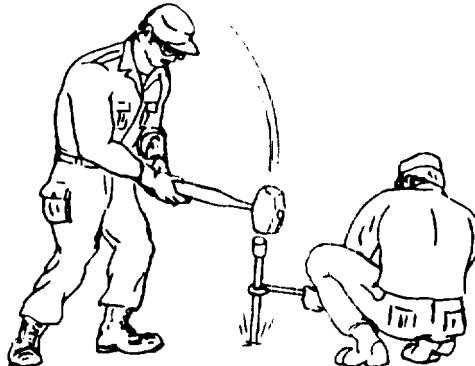

2-21. (cont)

c. Drive each of eight loop and clamp ground anchors into ground approximately 3 feet (91.5 cm) deep, and as close as possible to the shelter attaching points, at locations indicated below.

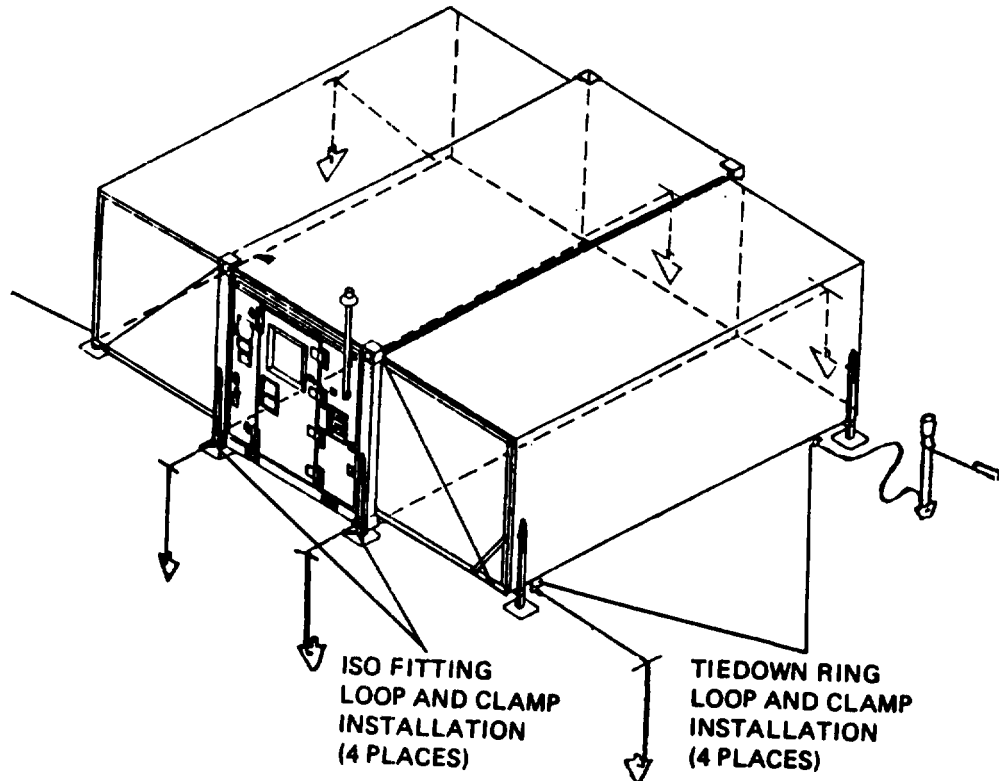

d. Set each ground anchor by forming a loop in cable end and secure loop with clamp.

e. Insert driving rod through loop and pull it set into ground.

NOTE

This setting of the anchor is required to turn the anchor in the ground so that it develops maximum holding power.

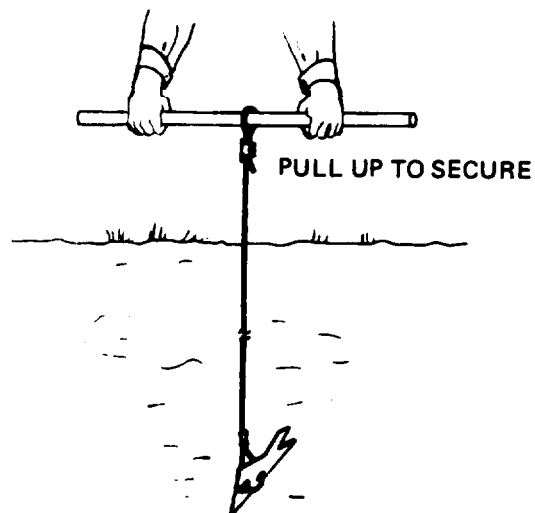

2-21. (cont)

- f. Remove clamp, loop cable at eight places (four with tiedown rings) as shown. Replace clamp and tighten clamp nuts.

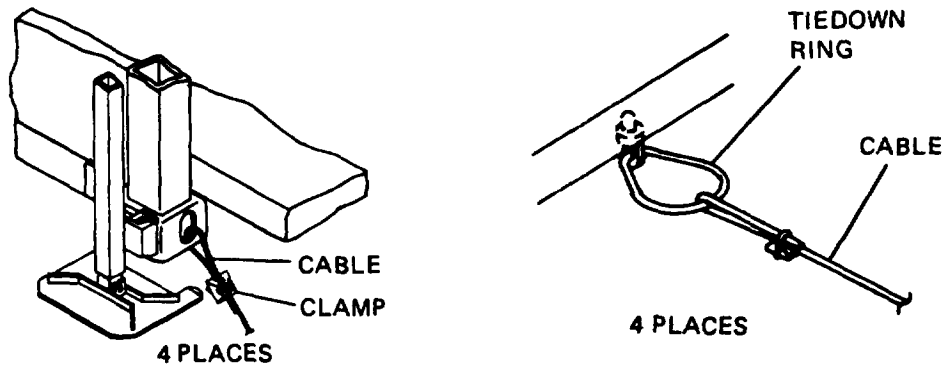

NOTE

When moving shelter, disassemble storm configuration kit and cut cable as close to ground as possible. Discard cable components. Retain the four tiedown rings and store in equipment container.

2-22. OPERATION DURING BLACKOUT CONDITIONS

NOTE

During blackout condition, enter and leave shelter through personnel door only. Do not operate exterior area light.

- a. Activate all interior lights and check from 25 feet (7.6 meters) away to ensure no light is visible.
- b. Place blackout override switch to OFF position.

NOTE

Blackout override switch must remain in OFF position for duration.

CHAPTER 3

OPERATOR MAINTENANCE INSTRUCTIONS

Section I. TROUBLESHOOTING PROCEDURES

3-1. GENERAL . This section contains operator troubleshooting information for locating and correcting common malfunctions which may develop in shelter.

WARNING

HIGH VOLTAGE

exists in the electrical system of this equipment

DEATH ON CONTACT

may result if personnel fail to observe safety precautions.

a. Paragraph 3-2 lists common malfunctions which you may find during operation or maintenance of shelter electrical system or components. You should perform inspections and corrective actions in order listed.

b. All malfunctions that may occur and all inspections and corrective actions may not be listed. If a malfunction is not listed or is not corrected by corrective action, notify your supervisor.

c. When troubleshooting operation of shelter electrical system, all switches and circuit breakers shall be placed in OFF positions with power connected.

d. The operator is limited to setting circuit breakers (ON/OFF), setting light assemblies in place, and replacing light bulbs.

3-2. OPERATOR TROUBLESHOOTING

MALFUNCTION

TEST OR INSPECTION

CORRECTIVE ACTION

1. NO POWER DISTRIBUTION TO SHELTER.

Step 1. Check that outside power is properly connected to service entrance connector on power entry panel, and check general condition of cable and connectors.

a. Make proper power connection.

b. Check for defective cable or connectors.

3-2. (cont)

MALFUNCTION

TEST OR INSPECTION
CORRECTIVE ACTION

- Step 2. Check and reset main circuit breaker, and check outside power.
Notify organizational maintenance.
2. INCANDESCENT LIGHT FAILS TO COME ON.
- Step 1. Check and reset circuit breaker.
- Step 2. Check visually for burned out incandescent bulb.
Change bulb. (Refer to paragraph 4-10.)
- Step 3. Check operation of incandescent light switch and blackout override switch.
Notify organizational maintenance.

WARNING

In the event of lamp breakage, care must be taken in removal of broken glass fragments and white phosphorous dust that may be dispersed within fixture. Inhalation of phosphorous dust could cause serious injury.

3. ALL FIXED ROOF AREA AND HINGED ROOF AREA CEILING LIGHTS FAIL TO COME ON.
- Step 1. Check operation of fluorescent light switch and blackout override switch.
- Step 2. Check and reset circuit breaker.
Notify organizational maintenance.
4. ONE OR MORE HINGED ROOF AREA CEILING LIGHTS FAIL TO COME ON.
- Step 1. Check to see if associated flexible cable connector is properly plugged in.
Make proper connection.
- Step 2. Check associated flexible cable and connectors for defects.
Notify organizational maintenance.

3-2. (cont)

MALFUNCTION

TEST OR INSPECTION

CORRECTIVE ACTION

- Step 3. Check visually for burned out fluorescent lamps.
- a. Unplug flexible cable connector and replace lamp. (Refer to paragraph 3-5.)
 - b. Reconnect flexible cable connector.
5. ONE OR MORE FIXED ROOF AREA CEILING LIGHTS FAIL TO COME ON.
Check visually for burned out fluorescent lamps.
- a. Turn off appropriate circuit breaker and replace lamp. (Refer to paragraph 4-12.)
 - b. Turn on appropriate circuit breaker.
6. NO POWER AT ONE OR MORE INTERIOR UTILITY OUTLETS.
Check and reset associated circuit breakers.
Notify organizational maintenance.
7. NO POWER AT ONE OR BOTH EXTERIOR UTILITY OUTLETS.
Check and reset circuit breaker.
Notify organizational maintenance.
8. AREA LIGHT FAILS TO COME ON.
Step 1. Check and reset circuit breaker.
Step 2. Check visually for burned out bulb.
Change bulb.
Notify organizational maintenance.
9. NO POWER AT HEATER/AC SUPPLY.
Step 1. Check that outside power is properly connected to service entrance connector on power entry panel, and check general condition of cable and connectors.
- a. Make proper power connection.
 - b. Check for defective cable or connectors.
- Step 2. Check and reset circuit breakers.
Notify organizational maintenance,

Section II. OPERATOR MAINTENANCE PROCEDURES

3-3 GENERAL. Authorized maintenance procedures to be performed by operator include replacement of area light assembly, replacement of light bulbs, hinged roof area ceiling lights, hinged panel leveling jack assemblies, endwall closeout panel, sidewall closeout panels, ECU intake panel, ECU return panel, container lift jack assemblies, storm configuration components, support braces, and leveling jack extensions.

3-4. AREA LIGHT ASSEMBLY REPLACEMENT

This task covers:

- a. Removal
 - b. Installation
-

WARNING

Disconnect power of circuit involved by setting circuit breaker to off position.

REMOVAL

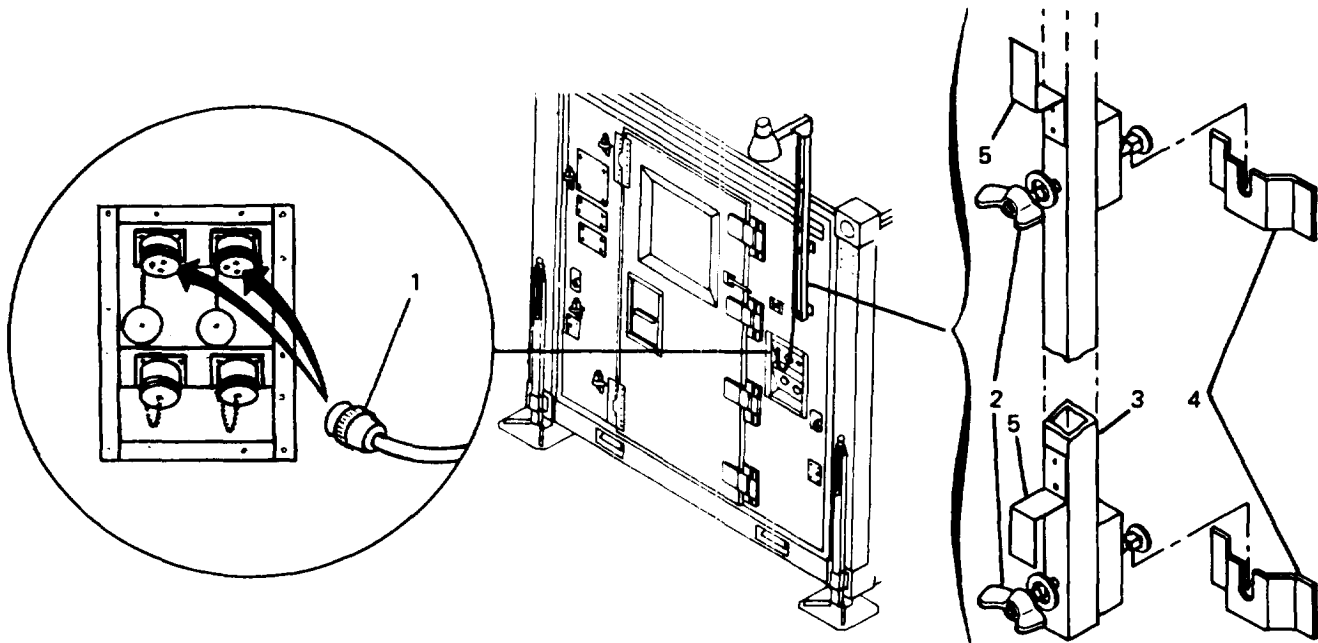

1. Place circuit breaker CB8 to off position.
2. Disconnect area light assembly connector (1) from power entry panel.
3. Loosen two wingnuts (2) and lift area light assembly (3) from two brackets (4) on shelter.
4. Coil cable on brackets (5) on light post.

3-4. (cont)

INSTALLATION

1. Position post of area light assembly (3) in two brackets (4) on shelter and tighten two wingnuts (2) to secure light to shelter.
2. Connect area light assembly connector (1) to power entry panel.
3. Place circuit breaker CB8 to on position.

3-5. HINGED ROOF AREA CEILING LIGHT REPLACEMENT

This task covers:

- a. Removal
 - b. Installation
-

WARNING

This fixture contains voltage that is dangerous if contacted. Before replacing hinged roof area ceiling light, make sure that electrical power is completely disconnected from circuit involved.

REMOVAL

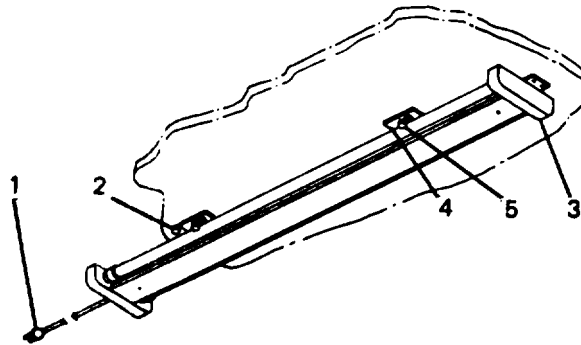

1. Place ceiling light switch and circuit breaker CB6 to off position.
2. Unplug cable connector (1) from receptacle outlet (twist-lock type connector) .
3. Retract plunger (2) and slide hinged roof area ceiling light (3) toward cable end to disengage two brackets (4) from four captive studs (5) in hinged roof.

INSTALLATION

1. Place hinged roof area ceiling light (3) against hinged roof with holes in two brackets (4) over four captive studs (5).
2. Slide light away from cable end to engage two brackets (4) on four captive studs (5).
3. Plug cable connector (1) in receptacle outlet.

3-6. HINGED PANEL LEVELING JACK ASSEMBLY REPLACEMENT

This task covers:

- a. Removal
- b. Cleaning, Inspection
- c. Installation

INITIAL SETUP

Standard tools

General mechanics tool kit

Personnel - 2

REMOVAL

1. Place sufficient blocks under hinged floor to prevent settling of expanded side when jack is removed.

NOTE

Stencil on jack indicates handle rotation to raise or lower jack.

2. Remove safety pin (1).
3. Rotate handle (2) to lower jack until jack hook (3) and jack lift pin (4) are disengaged.
4. Remove jack.

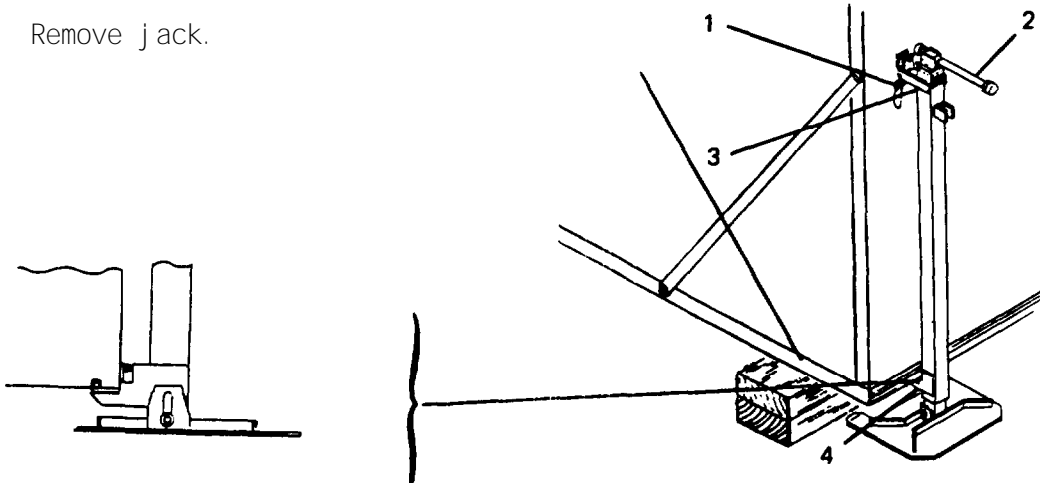

CLEANING, INSPECTION

1. Clean jack assembly and component surfaces.
2. Inspect mounting surfaces for corrosion and damage.
3. Inspect for missing or damaged components.
4. Inspect for corrosion or paint damage.

3-6. (cont)

INSTALLATION

1. Rotate handle (2) to raise jack until jack lift pins (4) engages hinged floor sockets (7) and jack hook (3) engages jack support bracket (5) on hinged sidewall.
2. Install safety pin (1) through jack support bracket (5) under jack hook (3).
3. Rotate handle (2) to raise jack until block is free.
4. Check proper alignment of positioning marks and proper compression and placement of seals.
5. Remove blocks.
6. Swing handle (2) down and secure in locking clip (6).

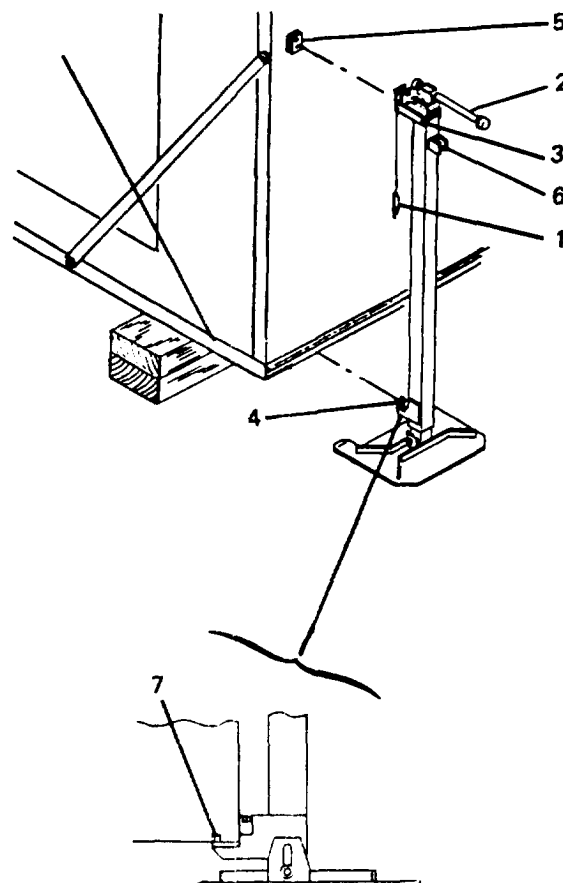

3-7. ENDWALL CLOSEOUT PANEL REPLACEMENT

This task covers:

- a. Removal
 - b. Installation
-

INITIAL SETUP

Standard Tools

General mechanics tool kit

Personnel -2

REMOVAL

WARNING

When hinged floor is in deployed position, do not disconnect support cable from hinged floor until stop plates on load balancer (inside shelter) have been locked with quick release pins to prevent return of support cable.

1. Move flexible electrical cable to facilitate removal of endwall
2. Inside shelter, loosen twelve captive screws (1) and remove endwall closeout panel (2).

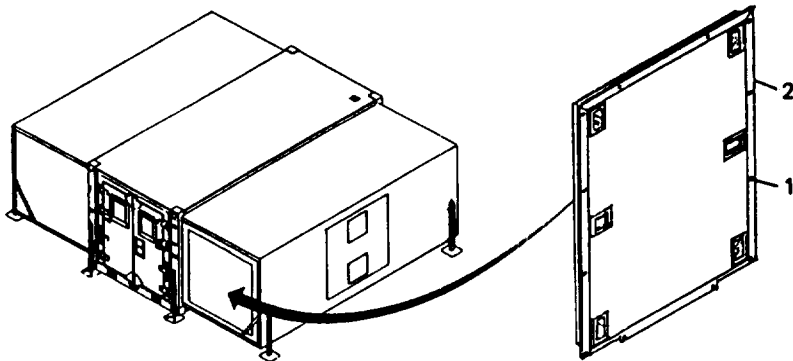

INSTALLATION

NOTE

Endwall closeout Panel (2) is stowed on outside of hinged sidewall when-not in use.

Position endwall closeout panel (2) against shelter endwall and secure by tightening twelve captive screws (1), placing bottom end in first

3-8. SIDEWALL CLOSEOUT, ECU INTAKE, AND ECU RETURN PANELS REPLACEMENT

This task covers:

- a. Removal
- b. Installation

INITIAL SETUP

Standard Tools

General mechanics tool kit

Personnel - 2

REMOVAL

1. If environmental control unit (ECU) panels are installed and ECU is operating, shut down ECU. (Refer to appropriate shelter system manual.)
2. Disconnect ECU ducts. (Refer to appropriate shelter system manual.)

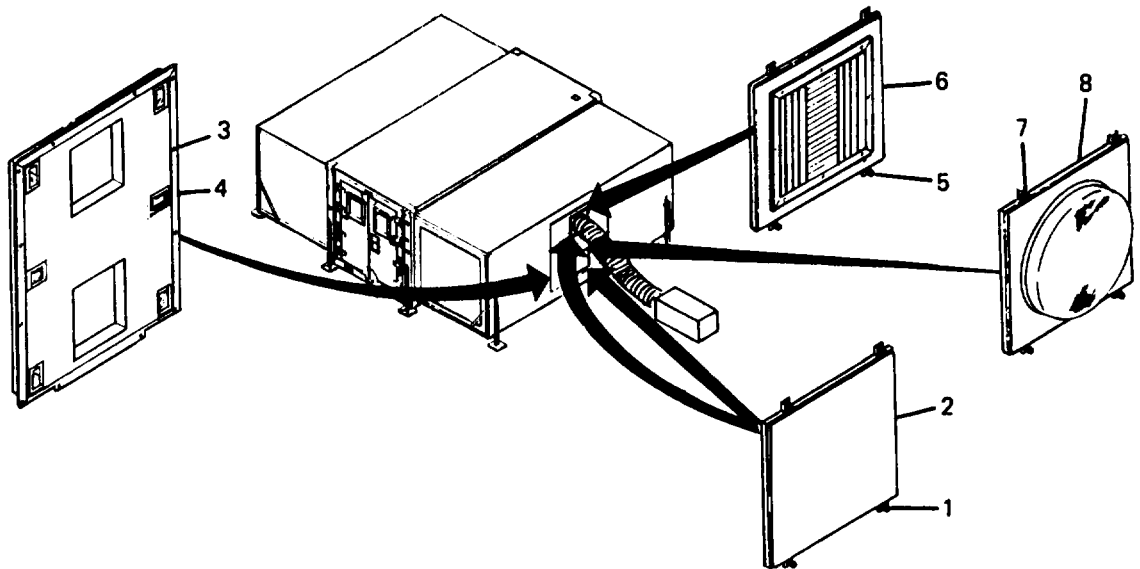

SideWall Closeout Panels

3. Inside shelter, loosen four captive screws (1) and remove small sidewall closeout panel (2).
4. Inside shelter, loosen twelve captive screws (3) and remove large sidewall closeout panel (4).

3-8. (cont)

ECU Intake Panel

Inside shelter, loosen four captive screws (5) and remove ECU intake panel (6).

ECU Return Panel

Inside shelter, loosen four captive screws (7) and remove ECU return panel (8).

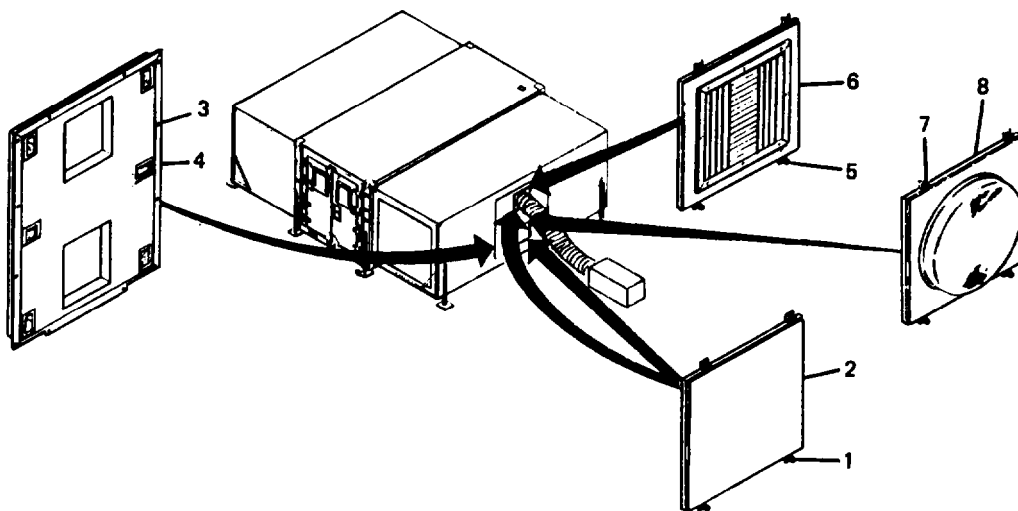

INSTALLATION

NOTE

ECU intake panel (6) and ECU return panel (8), or sidewall closeout panels (2) are stowed in roof panel when not in use. Sidewall closeout panels (4) are stowed on outside of hinged sidewall when not in use.

ECU Return Panel

Position ECU return panel (8) in frame opening and secure by tightening four captive screws (7).

3-8. (cont)

ECU Intake Panel

Position ECU intake panel (6) in frame opening and secure by tightening four captive screws (5).

Sidewall Closeout Panels

1. Position sidewall closeout panel (4) in frame opening bottom first and secure by tightening twelve captive screws (3).
2. Position sidewall closeout panels (2) in frame opening and secure by tightening four captive screws (1).
3. Connect ECU ducts and turn on ECU. (Refer to appropriate shelter system manual.)

3-9. CONTAINER LIFT JACK ASSEMBLY REPLACEMENT

This task covers:

- a. Removal
- b. Cleaning, Inspection
- c. Installation

INITIAL SETUP

Standard tools

General mechanics tool kit

Personnel - 2

REMOVAL

1. Place sufficient blocks under ISO fitting to prevent settling of shelter when jack is removed.

NOTE

Stencil on jack indicates handle rotation to raise or lower jack.

1. Remove safety pin (1).
2. Rotate handle (2) to lower jack until upper (3) and lower jack attachments (4) will disengage and jack is not supporting shelter.
3. Turn locking handle (5) to rotate insert (6) in ISO fitting (7),
4. Remove jack.

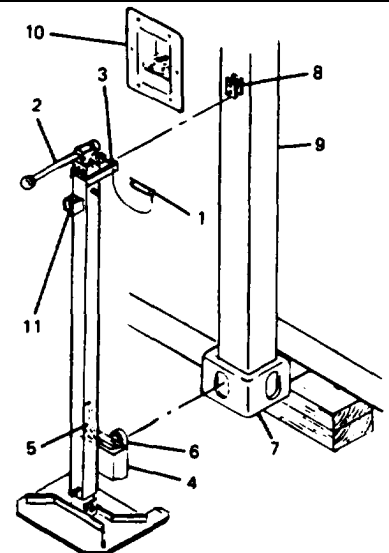

3-9. (cont)

CLEANING, INSPECTION

1. Clean jack assembly and component surfaces.
2. Inspect mounting surfaces for corrosion and damage.
3. Inspect for missing or damaged components.
Inspect for corrosion or paint damage.

INSTALLATION

1. Rotate handle (2) to raise jack until insert (6) will enter lower ISO fitting (7) and upper jack attachment (3) engages jack support bracket (8) on corner post (9).
2. Turn locking handle (5) to rotate insert (6) in ISO fitting (7).
3. Install safety pin (1) through jack support bracket (8) under upper jack attachment (3).
4. Watch level indicator (10), and rotate handle (2) to raise jack until shelter is leveled.
5. Swing handle (2) down and secure in locking clip (11).
6. Remove blocks.

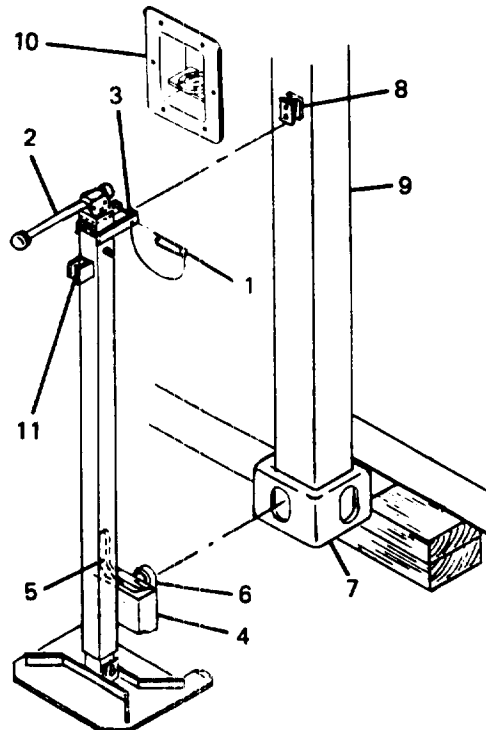

3-10. STORM CONFIGURATION COMPONENTS, SUPPORT BRACES, AND LEVELING JACK
EXTENSIONS REPLACEMENT

This task covers:

- a. Removal
 - b. Installation
-

INITIAL SETUP

Standard Tools

General mechanics tool kit
Personnel - 2

References

para. 2-21 Operation in High Winds

REMOVAL

Storm Configuration Components

1. Cut cable of eight anchor assemblies (1) as close to ground as possible. Discard cable components.
2. Unscrew four tiedown rings (3) from bottom of hinged floor panel (2). Retain the four tiedown rings and store in equipment container.

NOTE

Drive rod (4), drive head (5), and holding handle (6) can be removed from equipment container (7).

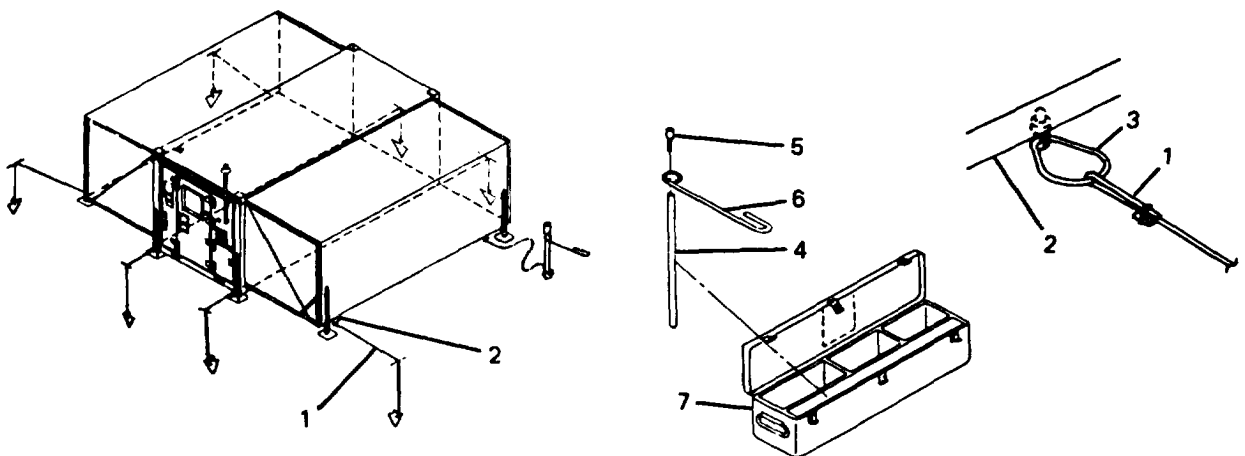

3-10. (cont)

Support Braces

Remove support braces (8) from hinged sidewalls (9) and hinged floor panel (2) by pulling straight out disengaging pins on braces from holes in panels.

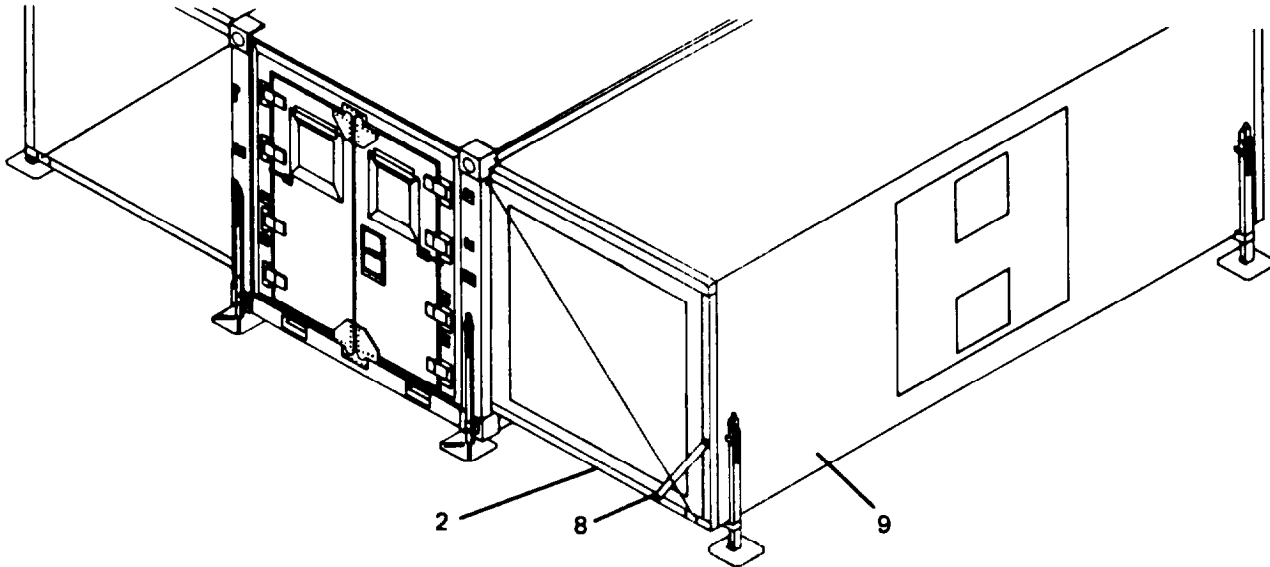

Leveling Jack Extensions

1. Remove two quick-disconnect pins (10) from outside tube of jack extension (11).
2. Lift jack assembly (12) off jack extension (11).
3. Remove pin (13) securing jack extension (11) to base (14) and lift jack extension off base.

INSTALLATION

Leveling Jack Extensions

1. Position jack extension (11) in base (14) and secure by installing pin (13).
2. Position jack assembly (12) on jack extension (11) and secure by installing two quick-disconnect pins (10) through tubes of jack extension and jack assembly.

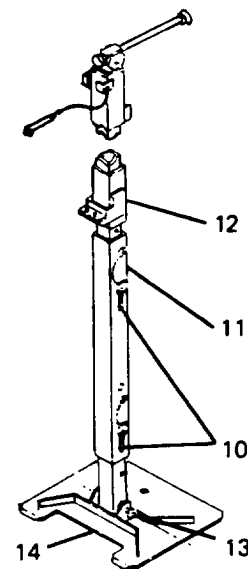

3-10. (cont)

Support Braces

Install support braces (8) in hinged sidewall (9) and hinged floor panel (2) by pushing straight in engaging pins on braces in holes on panels.

Storm Configuration Components

Refer to paragraph 2-21 for installation of storm configuration components.

CHAPTER 4
ORGANIZATIONAL MAINTENANCE INSTRUCTIONS

Section I. REPAIR PARTS, SPECIAL TOOLS, TMDE, AND SUPPORT EQUIPMENT

4-1. COMMON TOOLS AND EQUIPMENT.

- a. Appendix B, Section III contains the authorized common tools.
- b. For authorized equipment refer to Modified Table of Organization and Equipment (MTOE) applicable to your unit.

4-2. SPECIAL TOOLS, TMDE, AND SUPPORT EQUIPMENT.

- a. A special tool, hand blind riveter, Appendix B, Item 2 is used for shelter skin repair and general riveting utilizing blind rivets.
- b. Installation tools, Appendix B, Items 3 and 9 are used for installation of captive screws.
- c. Portable electric router, Appendix B, Item 15 is used to cut out panels. Use tripod base heat lamp, Appendix B, Item 16 during panel repair.
- d. Snap ring pliers, Appendix B, Item 10, is used to remove and install retaining rings on closeout panels.
- e. Fastener header, Appendix B, Item 7 or 8 and box end or adjustable wrench, Appendix B, Item 11 are used to install non-potted inserts.
- f. Multimeter, Appendix B, Item 4, is used to perform all continuity/voltage tests on shelter. Electric tool kit, Appendix B, Item 5 is used to repair wiring.
- g. Use portable electric drill, Appendix B, Item 6 to drive hinge pins.
- h. Blind bolt removal tool kit, Appendix B, Item 13, is used to remove rivets on hinge edge members of floor panel.
- i. Installation tool, Appendix B, Item 14 is used to install rivets on hinge edge members of floor panel.
- i. Use crimping tool, Appendix B, Item 12, to attach wires to receptacle pins on power entry panel.

4-3. REPAIR PARTS. Repair parts covering organizational maintenance for this shelter are listed and illustrated in TM 10-5411-200-24P.

Section II. TROUBLESHOOTING PROCEDURES

4-4. GENERAL. This Section contains organizational troubleshooting information for locating and correcting common malfunctions which may develop in shelter electrical system.

WARNING

The shelter contains voltages that are dangerous if contacted. Take appropriate precautions when troubleshooting. Before performing continuity checks or replacing electrical components, make sure that electrical power is disconnected from circuit involved.

4-5. TROUBLESHOOTING. Each malfunction for an individual component or unit is listed in paragraph 4-6. The malfunction is followed by a list of tests or inspections which help to determine probable causes and corrective actions to take. The tests or inspections and corrective actions are to be performed in the order listed in the table. All malfunctions that may occur and all tests or inspections and corrective actions may not be listed. If a malfunction is not listed or is not corrected by corrective action, notify your supervisor. Unless otherwise noted, when troubleshooting operation of shelter electrical system, all switches and circuit breakers shall be placed in operating positions with power connected. The electrical system schematic diagram (4-45) and wire list (4-46) are located at the end of Chapter 4, Section III.

4-6. ORGANIZATIONAL MAINTENANCE TROUBLESHOOTING

MALFUNCTION

TEST OR INSPECTION

CORRECTIVE ACTION

1. NO POWER DISTRIBUTION TO SHELTER.

Step 1. Check that outside power is properly connected to service entrance on power entry panel, check general condition of cable and connectors. Test operation of power entry panel.

- a. Replace defective wiring (paragraph 4-8).
- b. Replace defective connectors (paragraph 4-8).

Step 2. Test operation of main circuit breaker and wiring (paragraph 4-7).

- a. Replace defective wiring (paragraph 4-7).
- b. Replace defective circuit breaker (paragraph 4-7).

4-6. (cont)

MALFUNCTION	TEST OR INSPECTION	CORRECTIVE ACTION
2.	INCANDESCENT LIGHT FAILS TO COME ON.	
	Step 1.	Check visually for burned out bulb. Replace bulb (paragraph 4-10).
	Step 2.	Test operation of incandescent light switch (S3), blackout override switch (S1) and wiring (paragraph 4-10). a. Replace defective wiring (paragraph 4-10). b. Replace defective switch (paragraph 4-10).
	Step 3.	Check and reset circuit breaker CB6. Replace defective circuit breaker (paragraph 4-7).
3.	ALL FLUORESCENT LIGHTS FAIL TO COME ON.	
	step 1.	Check and reset circuit breaker CB6. Replace defective circuit breaker (paragraph 4-7).
	Step 2.	Test operation of fluorescent light switch (S4), blackout override switch (S1), and wiring (paragraph 4-7). a. Replace defective wiring (paragraph 4-7). b. Replace defective switch (paragraph 4-7).
4.	ONE OR MORE FLUORESCENT LIGHTS IN THE EXPANDED SECTIONS FAIL TO COME ON.	
	Step 1.	Check visually for burned out fluorescent lamps. Replace lamp, (paragraph 4-12).
	Step 2.	Check associated flexible cable connectors for proper connection or defects. Make proper connection or replace damaged connector or flexible cable (paragraph 4-11).
	Step 3.	Test operation of fluorescent light fixture and wiring (paragraph 4-11). a. Replace defective wiring (paragraph 4-11). b. Replace defective light fixture (paragraph 3-5).

4-6. (cont)

MALFUNCTION

TEST OR INSPECTION

CORRECTIVE ACTION

5. ONE OR MORE FLUORESCENT LIGHTS IN THE FIXED SECTION FAIL TO COME ON.

Step 1. Check visually for burned out fluorescent lamps.

Replace lamp, (paragraph 4-12).

Step 2. Test operation of fluorescent light fixture and wiring (paragraph 4-12).

a. Replace defective wiring (paragraph 4-12).

b. Replace defective light fixture (paragraph 4-12).

WARNING

In the event of lamp breakage, care must be taken in removal of broken glass fragments and white phosphorous dust that may be dispersed within fixture. Inhalation of phosphorous dust could cause dangerous injury.

6. NO POWER AT ONE OR MORE UTILITY OUTLETS IN THE EXPANDED SECTIONS.

Step 1. Check and reset associated circuit breaker CB3, CB5, CB7.

Replace defective circuit breaker (paragraph 4-7).

Step 2. Test operation of utility outlet and wiring (paragraph 4-13).

a. Replace defective wiring (paragraph 4-13).

b. Replace defective outlet (paragraph 4-13).

7. NO POWER AT ECU SUPPLY CONNECTOR.

Step 1. Check and reset circuit breaker CB1.

Replace defective circuit breaker (paragraph 4-7).

Step 2. Test operation of connector and wiring (paragraph 4-8).

a. Replace defective wiring (paragraph 4-8).

b. Replace defective connector (paragraph 4-8).

4-6. (cont)

MALFUNCTION	TEST OR INSPECTION	CORRECTIVE ACTION
8.	NO POWER AT ONE OR BOTH EXTERIOR UTILITY OUTLETS.	
	Step 1.	Check and reset circuit breaker CB8. Replace defective circuit breaker (paragraph 4-7).
	Step 2.	Test operation of associated exterior utility outlet and wiring (paragraph 4-13). a. Replace defective wiring (paragraph 4-13). b. Replace defective outlet (paragraph 4-13).

Section III. ORGANIZATIONAL MAINTENANCE PROCEDURES

This section contains the following maintenance procedures for the shelter.

LIST OF FUNCTIONS

Function No.	Function	Function Ref. (paragraph)
1	Circuit Breaker Panel Assembly Testing, Replacement and Repair (Models NQOB and NQOD)	4-7
2	Replacement of Obsolete NQOB Circuit Breaker Panel With New NQOD Circuit Breaker Panel	4-7.1
3	Power Entry Panel Assembly Testing, Replacement and Repair	4-8
4	Area Light Assembly Testing and Repair	4-9
5	Incandescent Light Assembly Testing, Replacement and Repair	4-10
6	Hinged Roof Area Ceiling Light Testing and Repair	4-11
7	Fixed Roof Area Ceiling Light Testing, Replacement and Repair	4-12
8	Receptacle Outlets Testing, Replacement, and Repair	4-13
9	Wall Switches Replacement	4-14
10	Blackout Switch Replacement, Repair, and Adjustment	4-15
11	Wiring Testing, Replacement, and Repair	4-16
12	Personnel and Right Cargo Door Replacement, Repair, and Alignment	4-17
13	Left Cargo Door Replacement, Repair, and Alignment	4-18
14	Hinged Panel Leveling Jack Assemblies Service and Repair	4-19
15	Hinged Roof Panels Service, Replacement, Repair, and Alignment	4-20
16	Hinged Endwall Replacement and Repair	4-21
17	Hinged Sidewalls Replacement and Repair	4-22
18	Hinged Floor Panel Replacement and Repair	4-23

LIST OF FUNCTIONS (CONT)

Function No.	Function	Function Ref. (paragraph)
19	Container Lift Jack Assemblies Service and Repair	4-24
20	Personnel Door End Endwall Panel Replacement and Repair	4-25
21	Cargo Door End Endwall Panel Replacement and Repair	4-26
22	Roof Panel Assembly Repair	4-27
23	Floor Panel Repair	4-28
24	Camlock and Latch Cam Handle Replacement and Repair	4-29
25	Equipment Container Replacement and Repair	4-30
26	Drying Water-Soaked Areas In Panels	4-31
27	Blind Rivet Removal and Installation	4-32
28	Repair of Small Dent or Depression	4-33
29	Repair of Depression or Small Puncture	4-34
30	Repair of Puncture With Minimal Damage to Core	4-35
31	Repair of Puncture With Core Fracture	4-36
32	Repair of Damage With Extended Cracks	4-37
33	Repair of Puncture Through One Skin and Core	4-38
34	Repair of Puncture Through Both Skins and Core	4-39
35	Shelter Body Seals Replacement	4-40
36	Threaded Inserts Replacement	4-41
37	Caulking Repair Areas	4-42
38	Paint Refinishing	4-43
39	Decal Removal /Replacement	4-44

4-7. CIRCUIT BREAKER PANEL ASSEMBLY TESTING, REPLACEMENT, AND REPAIR (MODELS NOOB AND NOOD)

This task covers:

- | | |
|-------------------------|-----------------|
| a. Testing | d. Repair |
| b. Removal | e. Installation |
| c. Cleaning, Inspection | |

INITIAL SETUP

Standard Tools

General Mechanics Tool Kit

Test Equipment

Multimeter, Appendix B, Item 4
Electrical Tool Kit, Appendix B,
Item 5

Personnel Required

Electrician

4-7. (cont)

TESTING

WARNING

Disconnect electrical power from shelter before testing. Failure to observe this warning may cause death or serious injury to personnel.

1. Tag and disconnect shelter electrical power.
2. Set all circuit breakers and switches to OFF position.

NOTE

This procedure covers the obsolete NQOB circuit breaker panel and the new NQOD circuit breaker panel. These units are distinguishable by the nameplates (9) attached to the panel boards.

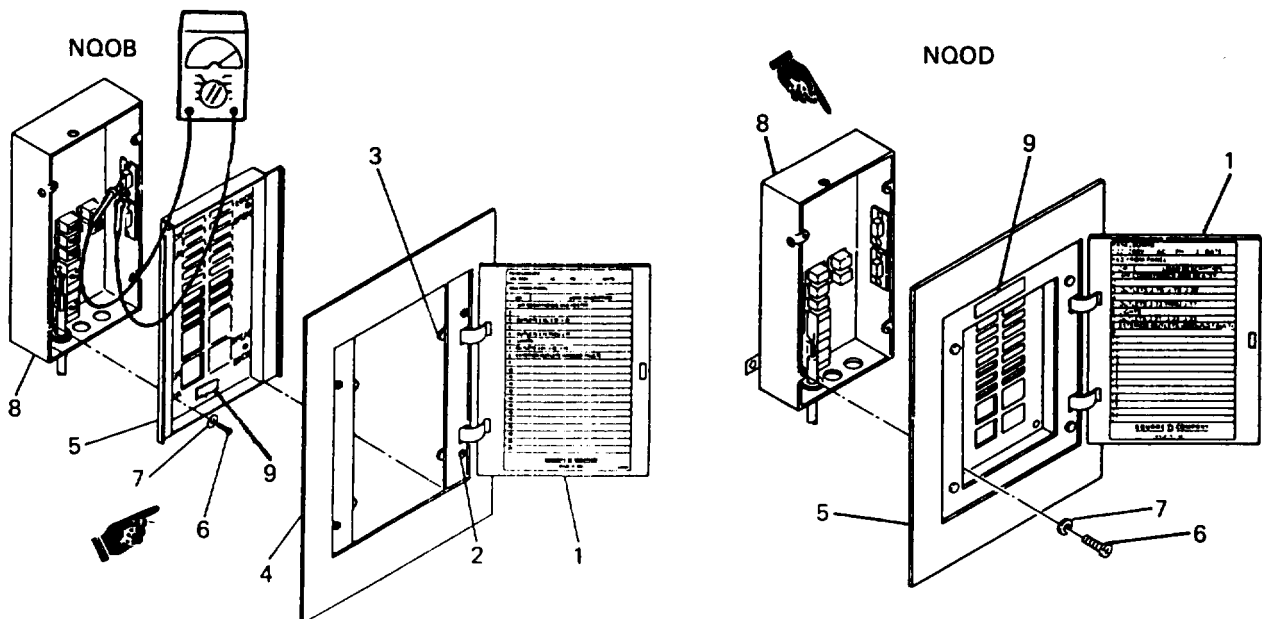

4-7. (cont)

3. Open circuit breaker panel door (1) on both models.
4. Loosen four captive screws (2) and move clamp fingers (3) to OPEN position on model NQOB.
5. Lift circuit breaker panel board (5) on model NQOB.
6. Remove four screws (6) and lift panel board (5) from circuit breaker box (8) on both models.

NOTE

Once the panelboards are removed, all further procedures are identical for both models.

7. Reconnect site power.
8. Set main circuit breaker to ON position.
9. Set branch circuit breakers to ON position and observe if any breakers pop to OFF position.
10. Disconnect site power.
11. Using multimeter, check for continuity of circuit breakers, light switches, and wiring.
12. If no continuity is present, replace defective circuit breaker, light switch, or panel wiring. (Refer to paragraph 5-2)

REMOVAL

WARNING

Disconnect electrical power from shelter before removing components. Failure to observe this warning may cause death or serious injury to personnel.

1. Tag and disconnect shelter electrical power.
2. Set all circuit breakers and switches to OFF position.

4-7. (cont)

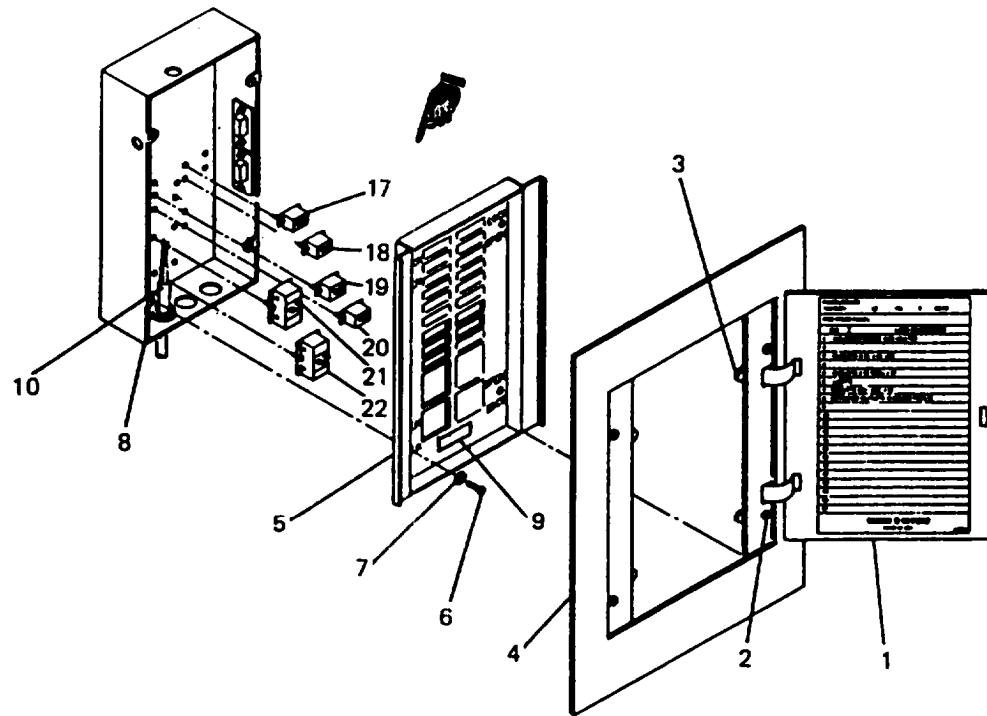

NOTE

This procedure covers the obsolete NQOB circuit breaker panel and the new NQOD circuit breaker panel. These units are distinguishable by the nameplates (9) attached to the panel boards.

3. Open circuit breaker panel door (1) on both models.
4. Loosen four captive screws (2) and move clamp fingers (3) to OPEN position on model NQOB.
5. Lift circuit breaker panel cover (4) from panel board (5) on model NQOB.
6. Remove four screws (6) and washers (7) and lift panel board (5) from circuit breaker box (8) on both models.

4-7. (cont)

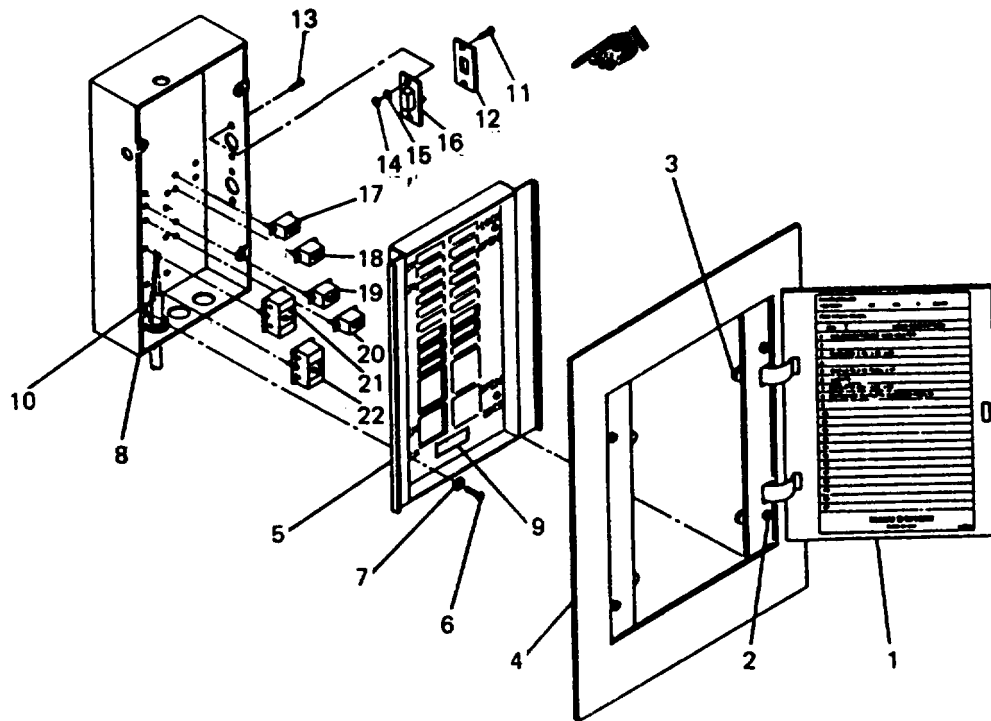

NOTE

Once the panel boards are removed, all further procedures are identical for both models.

7. Tag and disconnect wires (10) from light switches (16).
8. Remove four screws (11) and two switch covers (12).
9. Remove four screws (13), nuts (14), and lockwashers (15), and remove two light switches (16) from circuit breaker box (8).
10. Tag and disconnect wires (10) from circuit breakers (17 through 22).
11. Remove circuit breakers (17 through 22) from circuit breaker box (8).

CLEANING, INSPECTION

1. Clean circuit breaker panel and component surfaces.

4-7. (cont)

NOTE

Do not use water to clean circuit breaker panel assembly.

2. Inspect mounting surfaces for corrosion and damage.
3. Inspect for damaged circuit breakers or light switches.
4. Inspect panel wiring for cracks, tears, burns, or other damage.

REPAIR

1. Replace damaged circuit breakers or light switches.
2. Repair or replace damaged wiring.

INSTALLATION

Circuit Breaker

Install circuit breakers (17 through 22) in circuit breaker box (8).

Connect wires (10) to circuit breakers (17 through 22).

Light Switches

3. Position two light switches (16) in circuit breaker box (8) and secure with four screws (13), nuts (14), and lockwashers (15).
4. Position two switch covers (12) over light switches (16) and secure with four screws (11).
5. Connect wires (10) to light switches (16).
6. Attach panel board (5) to circuit breaker box (8) with screws (6) and washers (7).
7. Place panel cover (4) on model NQOB panel board (5), move clamp fingers (3) to LOCK position and tighten captive screws (2).
8. Close circuit breaker panel door (1).

4-7.1 REPLACEMENT OF OBSOLETE NQOB CIRCUIT BREAKER PANEL WITH NEW NQOD CIRCUIT BREAKER PANEL.

This task covers:

- a. Removal
- b. Disassembly
- c. Installation
- d. Assembly

INITIAL SETUP

Standard Tools

General Mechanics Tool Kit

Test Equipment

Blind Nut Assemblies (4),
Appendix E, Item 26
Conduit (P/N 5-4-5061-2)
New Circuit Breaker Panel
NQOD (P/N 5-4-3199)

Personnel Required

Electrician

WARNING

Disconnect electrical power from shelter before disassembling circuit breaker panel. Failure to observe this warning may cause death or serious injury to personnel.

NOTE

All parts removed from the obsolete NQOB circuit breaker panel are reusable in the installation of the new NQOD circuit breaker panel with the following exceptions: circuit breaker box, panel board, panel cover, and conduit entering the top of circuit breaker box. The new NQOD circuit breaker panel (P/N 5-4-3199) consists of breaker box and panel cover. The box is prepunched to accept light switches, wiring entry, and mounts for circuit breakers.

4-7.1 (cont)

REMOVAL

1. Tag and disconnect shelter electrical power.
2. Refer to paragraph 4-7 for removal of panel cover, panel board, light switches, circuit breakers.

DISASSEMBLY

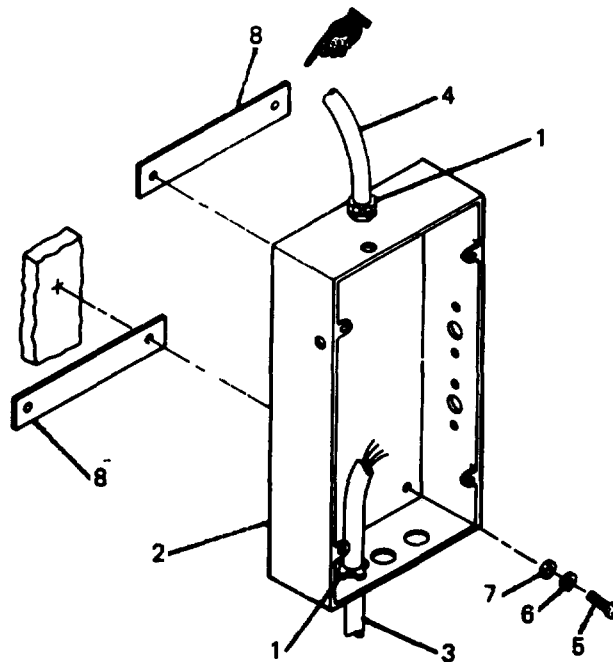

1. Remove insulated connectors (1) from inside circuit breaker box (2), pull conduit and wires, (3) and (4) away from box. Remove other end of conduit (4) from box on left side of roof beam. Slide conduit over wires and discard. A new piece of conduit which is 2-inches longer will be used during installation of new box.
2. Remove four screws (5), lockwashers (6), flat washers (7), and remove circuit breaker box (2) and spacers (8) from the wall.

4-7.1 (cont)

INSTALLATION

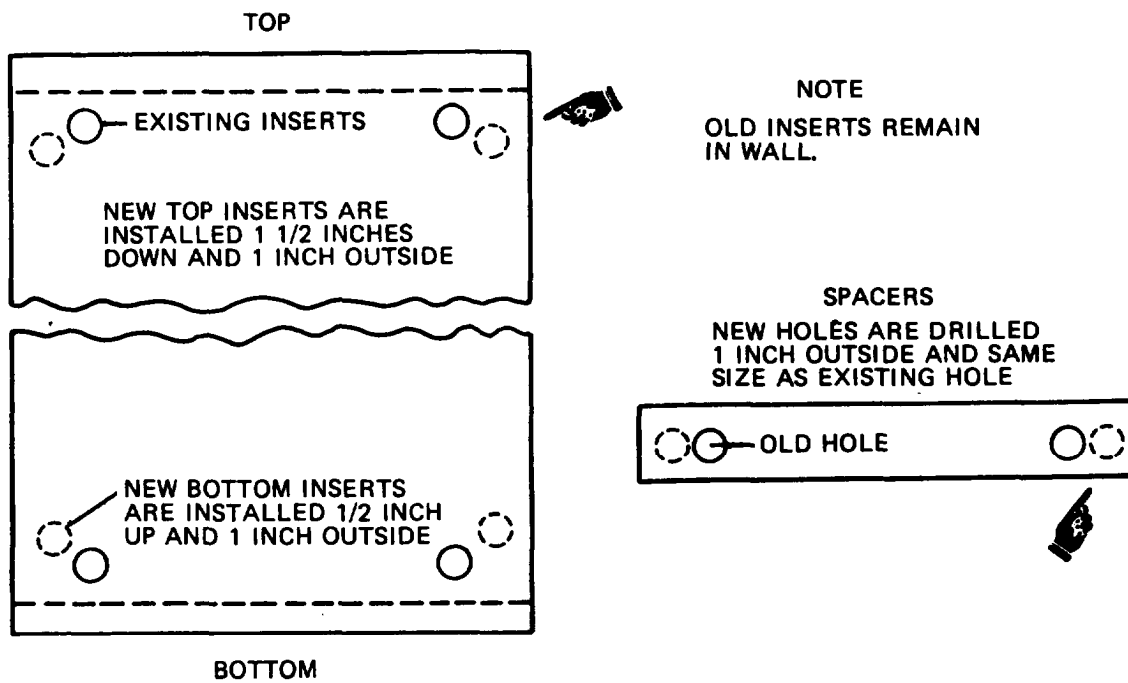

1. Install new inserts (refer to paragraph 4-41).
2. Drill new holes in spacers.

4-7.1 (cont)

ASSEMBLY

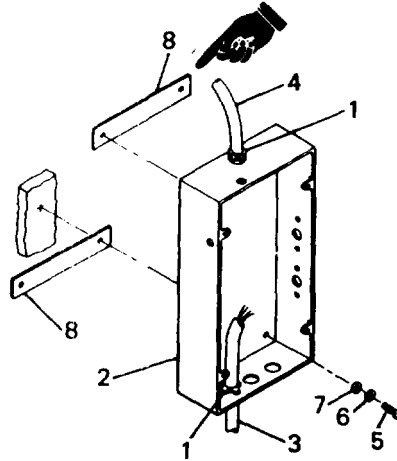

1. Align spacers (8) and circuit breaker box (2) with new inserts and secure with screws (5), lockwashers (6), and washers (7).
2. Slide new conduit (P/N 5-4-5061-2) over wires and secure in box on left side of roof beam.
3. Insert conduit (3) and (4) into circuit breaker box (2) and secure with insulated connectors (1).
4. Refer to paragraph 4-7 for installation of circuit breakers, light switches, wiring, and panel board with cover.
5. Connect shelter electrical power and remove tags.
6. Refer to paragraph 4-7 for testing.

4-8. POWER ENTRY PANEL ASSEMBLY TESTING, REPLACEMENT, AND REPAIR

This task covers:

- | | |
|-------------------------|-----------------|
| a. Testing | d. Repair |
| b. Removal | e. Installation |
| c. Cleaning, Inspection | |

INITIAL SETUP

Standard Tools

General Mechanics Tool Kit

Test Equipment

Multimeter, Appendix B, Item 4

Personnel Required

Electrician

4-8. (cont)

TESTING

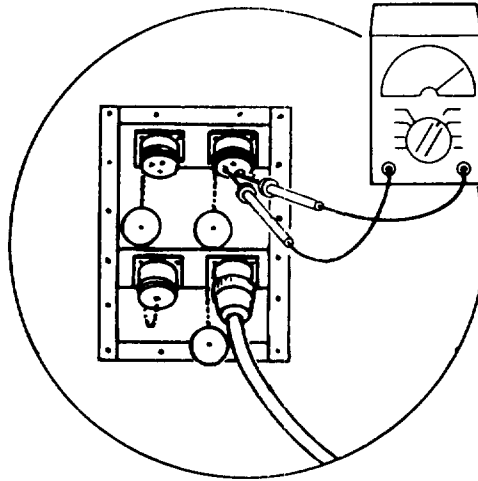

1. Connect site power.
2. Unscrew connector covers from connectors.
3. Set all circuit breakers in ON position.
4. Using multimeter, check for proper voltage at each receptacle pin.
5. If improper voltage is present, replace defective receptacles, terminals/connectors, or panel wiring. (Refer to paragraph 5-3)

Receptacles

1. Inside shelter, remove screws (1), lockwashers (2) and washers (3), and carefully lift cover assembly (4) away from personnel door end endwall panel as far as it will go.
2. Disconnect wires (20) from receptacles (10, 11, 17, and 18) at back of panel (5).

NOTE

Tag all wires for reconnection.

3. Remove screws (6), lockwashers (7), receptacle covers (8), and nuts (9).
4. Remove receptacles (10 and 11) and gaskets (12) from panel (5).
5. Remove screws (13), lockwashers (14), receptacle covers (15), nuts (16), and washers (19).
6. Remove receptacles (17 and 18) from panel (5).

4-8. (cont)

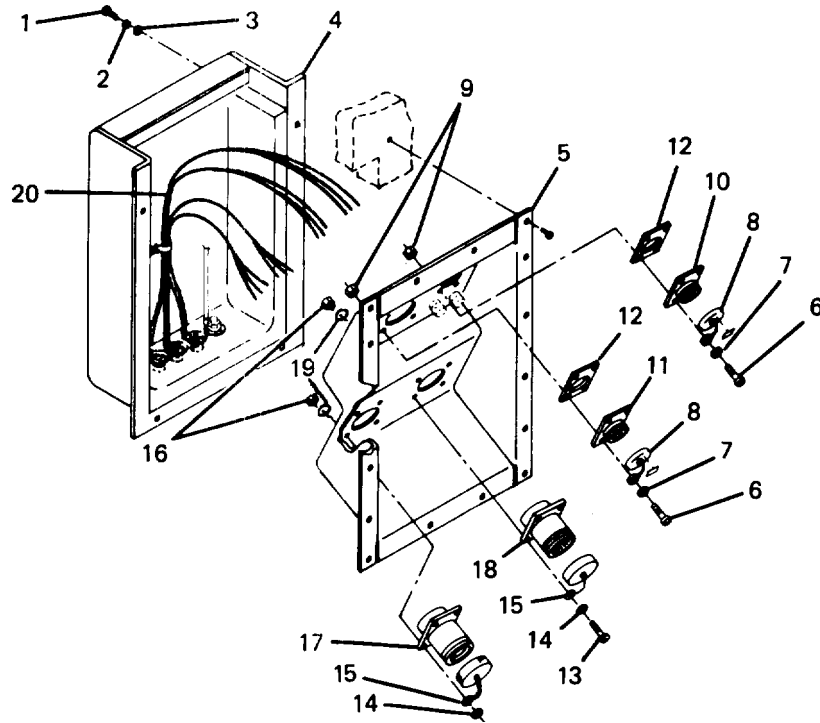

Terminal s/Connectors

7. Inside shelter, remove screws (1), lockwashers (2), and washers (3), and carefully lift cover assembly (4) away from personnel door end wall panel as far as it will go.

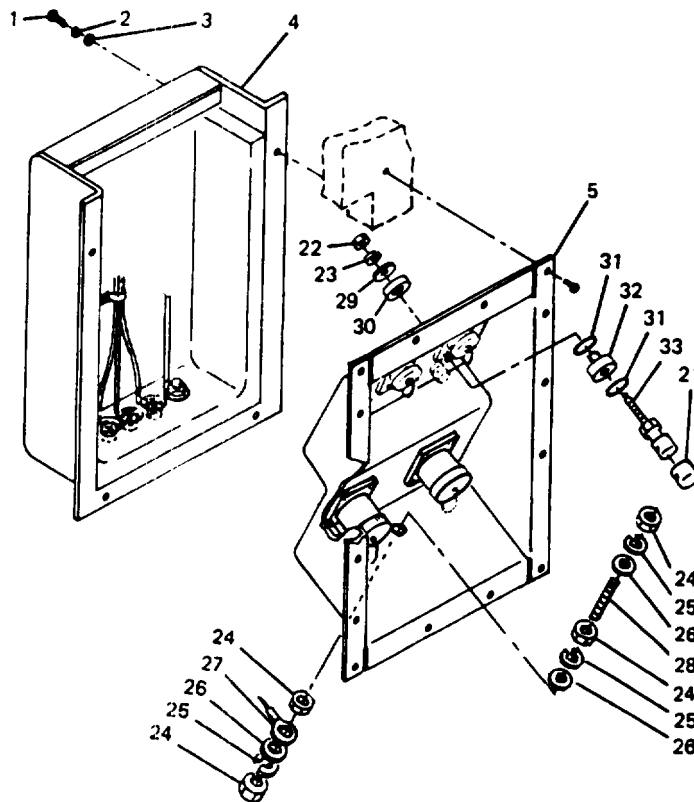

4-8. (cont)

8. Disconnect wires from terminals/connectors at rear of panel (5).

NOTE

Tag all wires for reconnection.

9. Remove rubber cap (21), nut (22), lockwasher (23), brass washer (29), nylon washer (30), two O-rings (31), nylon washer (32), and binding post body (33) from panel (5).
10. Remove four nuts (24), three lockwashers (25), three washers (26), terminal lug (27), and threaded stud (28) from panel (5).

CLEANING, INSPECTION

1. Clean power entry panel and component surfaces.
2. Inspect mounting surfaces for corrosion and damage.
3. Inspect for damaged receptacles, binding posts, terminals, or threaded stud.

Replace damaged receptacles, binding post, terminals, or threaded stud.

Terminals/Connectors

1. Install threaded stud (28), terminal lug (27), three washers (26), three lockwashers (25), and four nuts (24) in panel (5).
2. Install binding post body (33), nylon washer (32), two O-rings (31), nylon washer (30), brass washer (29), lockwasher (23), nut (22), and rubber cap (21) in panel (5).
3. Connect all wires to terminals/connectors at rear of panel (5). (Refer to paragraph 4-46)
4. Inside shelter, position cover assembly (4) against personnel door end wall panel and secure with washers (3), lockwashers (2), and screws (1).

4-8. (cont)

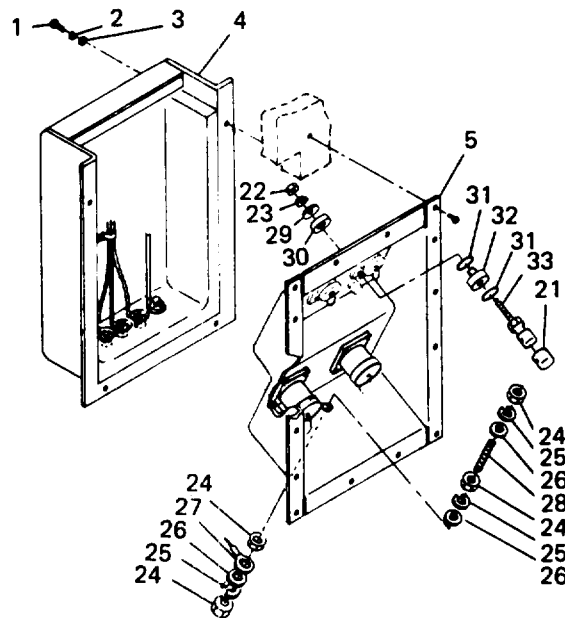

Receptacles

5. Install receptacles (17 and 18), nuts (16), washers (19), receptacle covers (15), lockwashers (14), and screws (13) in panel (5).
6. Install gaskets (12), receptacles (10 and 11), nuts (9), receptacle covers (8), lockwashers (7), and screws (6) in panel (5).
7. Connect all wires (20) to receptacles (10, 11, 17, and 18). (Refer to 4-46.)
8. Inside shelter, position cover assembly (4) against personnel door end wall panel and secure with washers (3), lockwashers (2), and screws (1).

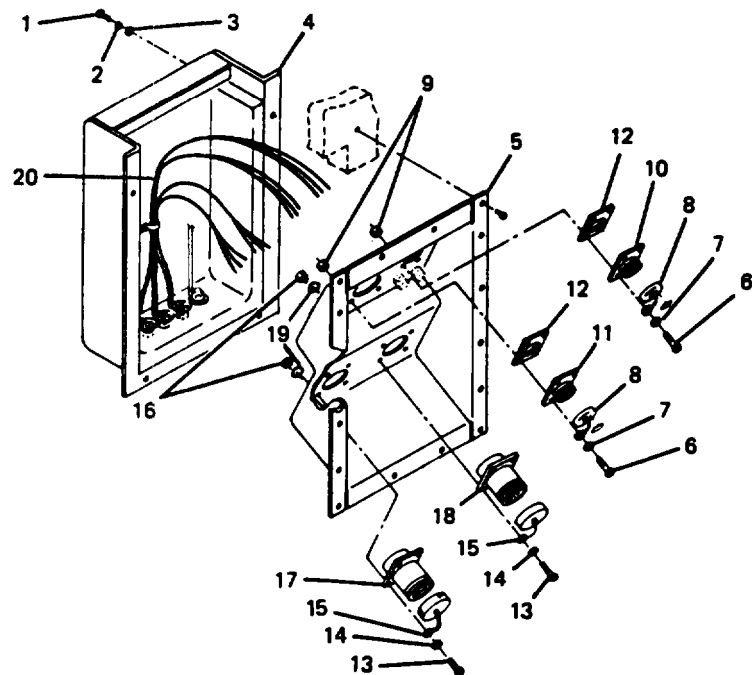

4-9. AREA LIGHT ASSEMBLY TESTING AND REPAIR

This task covers:

- a. Testing
- b. Disassembly
- c. Cleaning, Inspection
- d. Repair
- e. Assembly

INITIAL SETUP

Special Tools

Hand blind riveter, Appendix B, Item 2

Test Equipment

Multimeter, Appendix B, Item 4

Standard Tools

General mechanics tool kit

Personnel

Electrician

Sheet metal worker

Equipment Condition

Area light assembly removed (3-4)

All circuit breakers and switches in OFF position

TESTING

1. Remove flood light (1) from lamp holder (2).
2. Unscrew two captive screws (3) and remove conduit outlet cover (4) and gasket (5) from exterior light post (6).
3. Using multimeter, check for continuity at lamp socket and wiring.
4. If no continuity is present, replace defective lamp or wiring.

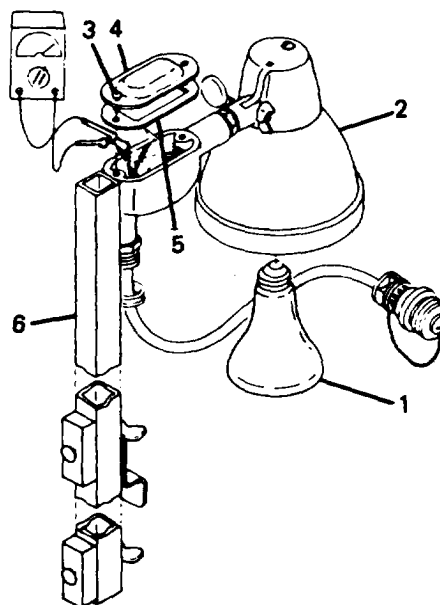

DISASSEMBLY

1. Unscrew flood light (1) from lamp holder (2).
2. Remove wing nut (3) and thumb screw (4) from lamp holder (2).
3. Unscrew two captive screws (5) and remove conduit outlet cover (6) and gasket (7).
4. Remove three wire nuts (8) and separate three wires in lamp holder (2) from three wires of electrical cord (9) in exterior light post (10).
5. Separate lamp holder (2) from exterior light post (10).
6. Remove locknut (21).

4-9. (cont)

7. Rotate screw on clamp (12) one-quarter turn, open clamp (12), and remove electrical cord (9).
8. Drill out two rivets (11) and remove clamp (12) from exterior light post (10). (Refer to paragraph 4-32)
9. Remove electrical cord (9) from exterior light post (10).
10. Separate liquid tight connector (13) and connector (14) from electrical cord (9).
11. Remove three terminal lugs (15) from three wires in electrical cord (9).
12. Remove two wing nuts (16), washers (17), and bolts (18) from exterior light post (10).
13. Drill out four rivets (19) and remove two cord storage brackets (20) from exterior light post (10). (Refer to paragraph 4-32)

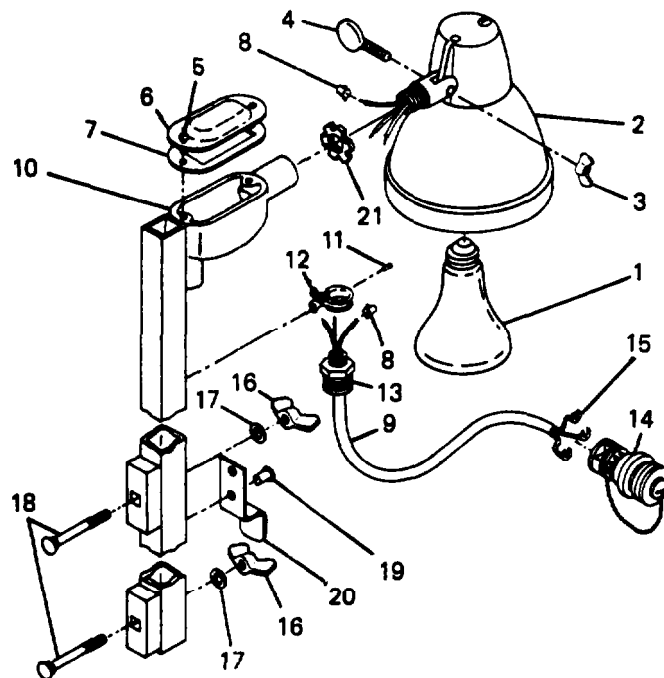

4-9. (cont)

CLEANING, INSPECTION

1. Clean area light assembly and component surfaces.
2. Inspect mounting surfaces for corrosion and damage.
3. Inspect for and replace if necessary:
 - a. Missing or damaged component
 - b. Corrosion or paint damage.

REPAIR

Repair corrosion or paint damage. (Refer to paragraph 4-43)

ASSEMBLY

1. Position two cord stowage brackets (20) on exterior light post (10) and install four rivets (19). (Refer to paragraph 4-32)
2. Install two bolts (18), washers (17), and wing nuts (16) in exterior light post (10).
3. Assemble three terminal lugs (15) to three wires on one end of electrical cord (9) and attach connector (14) at that end.
4. Place electrical cord (9) through clamp (12) and attach clamp to exterior light post with two rivets (11) and close clamp. (Refer to 4-32.)
5. Assemble liquid tight connector (13) to opposite end of electrical cord (9) and install assembly in exterior light post (10). Make sure three wires extend through opening at top of exterior light post (10).
6. Assemble locknut (21) on lamp holder (2).
7. Assemble lamp holder (2) to exterior light post (10) and install thumb screw (4) and wing nut (3). Make sure three wires extend through opening at top of exterior light post (10).
8. Connect three wires from electrical cord (9) to three wires from lamp holder (2) as follows:

From
Electrical Cord

Black Wire
White Wire
Green Wire

To
Lamp Holder

Black Wire
White Wire
Bare Wire

4-9. (cont)

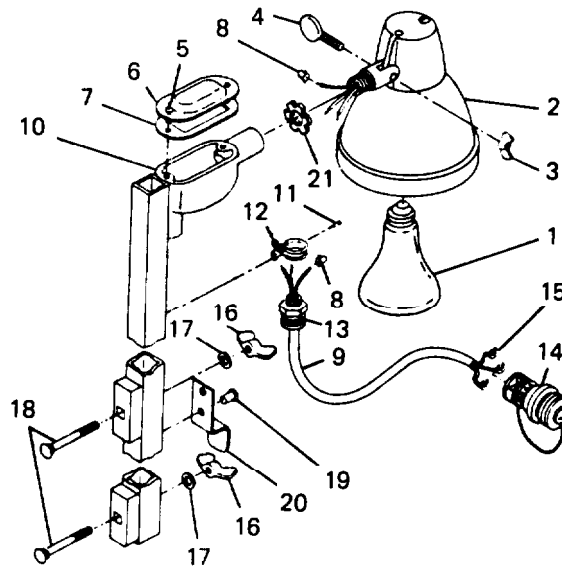

9. Secure these wires with three wire nuts (8).
10. Make sure connected wires are positioned in opening at top of exterior light post (10) and assemble gasket (7) and outlet cover (6) to top of exterior light post (10) with two captive screws (5).
11. Install flood light (1) in lamp holder (2).

4-10. INCANDESCENT LIGHT ASSEMBLY TESTING, REPLACEMENT AND REPAIR

This task covers.

- | | |
|-------------------------|-----------------|
| a. Testing | d. Repair |
| b. Removal | e. Installation |
| c. Cleaning, Inspection | |

INITIAL SETUP

Standard Tools

General mechanics tool kit

Test Equipment

Multimeter, Appendix B, Item 4

Personnel

Electrician

This fixture contains voltage that is dangerous if contacted. Before replacing incandescent light assembly, set all circuit breakers and switches to OFF position.

4-10. (cont)

TESTING

1. Set all circuit breakers and switches to OFF position.
2. Remove two screws (1) and cover (2).
3. Unscrew bulb (3) from light fixture (4).
4. Remove screw (5) and separate light fixture (4) from light fixture adapter (6) as far as it will go.
5. Using multimeter, check for continuity at bulb socket and wiring.
6. If no continuity is present, replace defective light fixture or wiring.

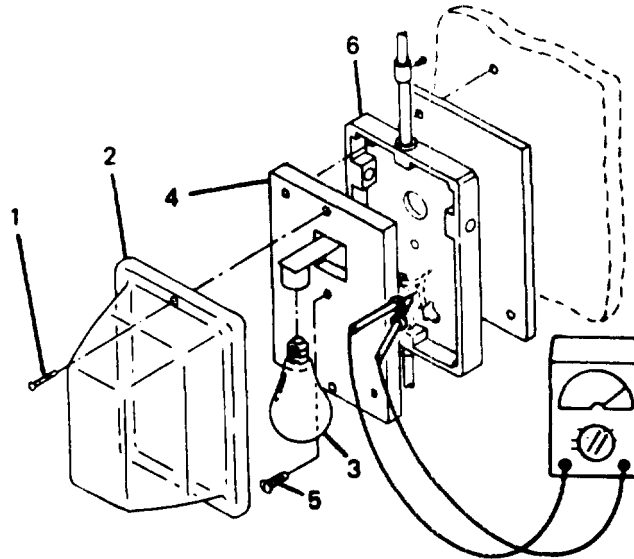

1. Remove two screws (1) and switch cover (2).
2. Remove two screws (3) and pull switch (4) from outlet box (27) as far as it will go.

4-10. (cont)

3. Disconnect wires at rear of switch (4).

NOTE

Tag wires for reconnection.

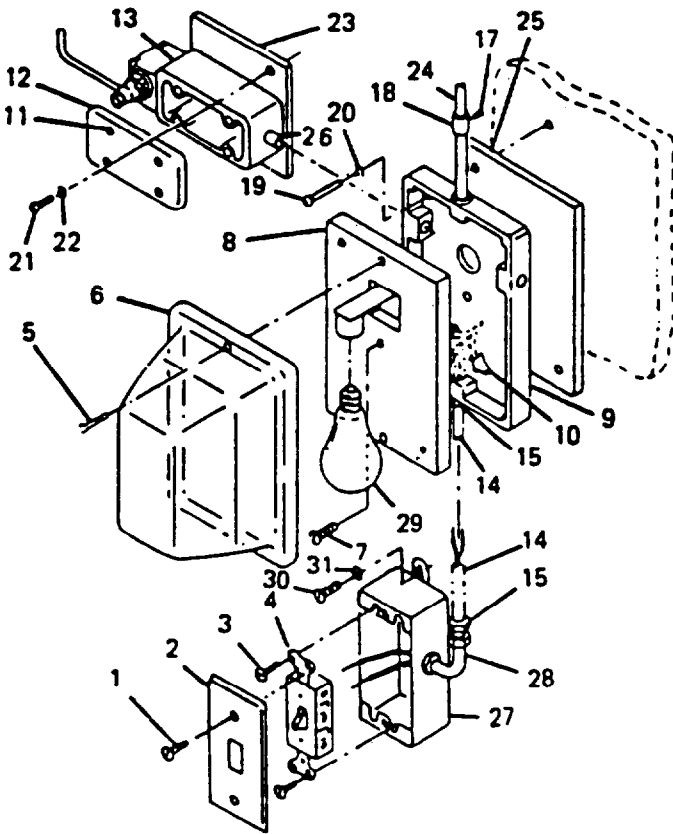

PRIOR TO S/N 1089

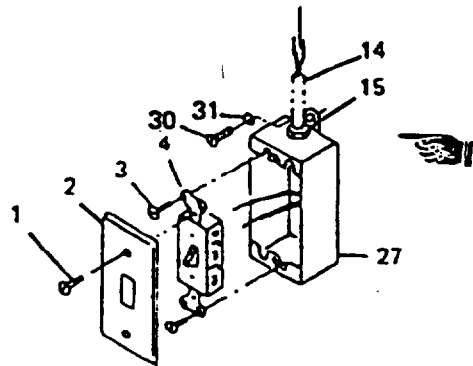

S/N 1089 AND SUBSEQUENT

4. Remove two screws (5) and light fixture cover (6). Remove bulb (29).
5. Remove screw (7) and separate light fixture (8) from light fixture adapter (9) as far as it will go.
6. Remove wire nuts (10) and disconnect wires from rear of light fixture (8).

NOTE

Tag wires for reconnection.

4-10. (cont)

7. Loosen four captive screws (11) and remove limit switch cover (12).
8. Disconnect three sets of wires plus one ground wire inside limit switch (13).

NOTE

Tag wires for reconnection.

9. Pull wires up through lower conduit (14) and into light fixture adapter (9).
10. Remove two screws (30) and lockwashers (31) and separate outlet box (27) from wall.
11. Loosen two insulating connectors (15) below light fixture adapter (9) and:
 - a. For units prior to S/N 1089, loosen insulating conduit connector (15) at elbow (28) and remove conduit (14).
 - b. For units with S/N 1089 and subsequent, loosen insulating conduit connector (15) at switch box (27) and remove conduit (14).
12. Loosen screw (17) at rear of offset connector (18).
13. Remove two screws (19) and lockwashers (20) from light fixture adapter (9).

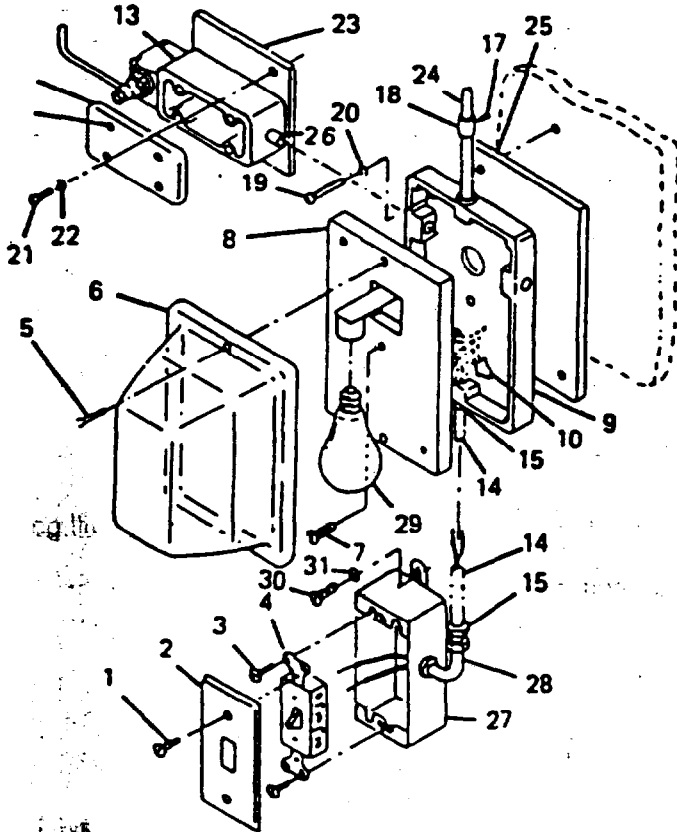

PRIOR TO S/N 1089

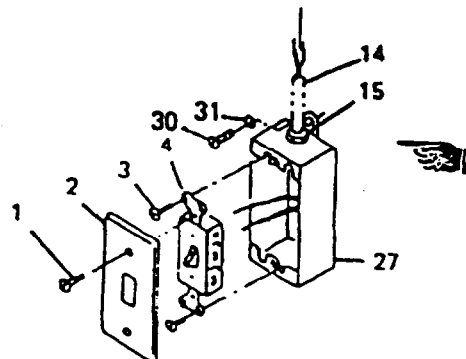

S/N 1089 AND SUBSEQUENT

4-10. (cont)

14. Remove two screws (21) and lockwashers (22) from limit switch mounting plate (23).
15. Lower light fixture adapter (9) and offset connector (18) together with limit switch (13) and limit switch mounting plate (23) from upper conduit (24).
16. Remove incandescent light spacer (25).
17. Separate light fixture adapter (9) from limit switch (13) and limit switch mounting plate (23) by unscrewing close nipple (26).

CLEANING, INSPECTION

1. Clean incandescent light assembly and component systems.
2. Inspect mounting surfaces for corrosion and damage.
3. Inspect for and replace if necessary:
 - a. Missing or damaged components.
 - b. Corrosion or paint damage.

REPAIR

Corrosion or paint damage. (Refer to paragraph 4-43)

INSTALLATION

1. Assemble limit switch (13) to limit switch mounting plate (23) to light fixture adapter (9) using close nipple (26).
2. Pass wiring through close nipple (26) into limit switch (13).
3. Connect wiring. (Refer to paragraph 4-46)
4. Position limit switch cover (12) on limit switch (13) and tighten four captive screws (11).
5. Pass wiring from upper conduit (24) through offset connector (18) at top of light fixture adapter (9) and position limit switch mounting plate (23) and light fixture adapter (9) with incandescent light spacer (25) behind it against endwall panel.
6. Install two screws (21) and lockwashers (22) securing limit switch (13) and limit switch mounting plate (23) to endwall panel.
7. Install two screws (19) and lockwashers (20) securing light fixture adapter (9) and incandescent light spacer (25) to endwall panel.

4-10. (cont)

8. Pull wiring down into light fixture adapter (9), position upper conduit (24) in hole at top of adapter, and tighten offset connector (16).
9. Tighten screw (17) at rear of offset connector (18).
10. Pass wiring for switch (4) through lower hole of light fixture adapter (9) and thread through lower conduit (14).
11. Position lower conduit (14) in hole at bottom of light fixture adapter (9) and tighten upper insulating connector (15).
12. Pull wiring through conduit (14) and:
 - a. For units prior to S/N 1089, pull wiring through elbow connector (26) and into outlet box (27).
 - b. For units with S/N 1069 and subsequent, pull wiring into outlet box (27).
13. Position lower conduit (14) into:
 - a. Elbow connector (26) (for units prior to S/N 1069) and tighten lower insulating connector (15).
 - b. Conduit outlet box (27) (for units with S/N 1069 and subsequent) and tighten lower insulating connector (15).
14. Position outlet box (27) against wall and secure with two screws (30) and lockwashers (31).
15. Position switch (4) near outlet box (27) and connect wires. (Refer to paragraph 4-46.)

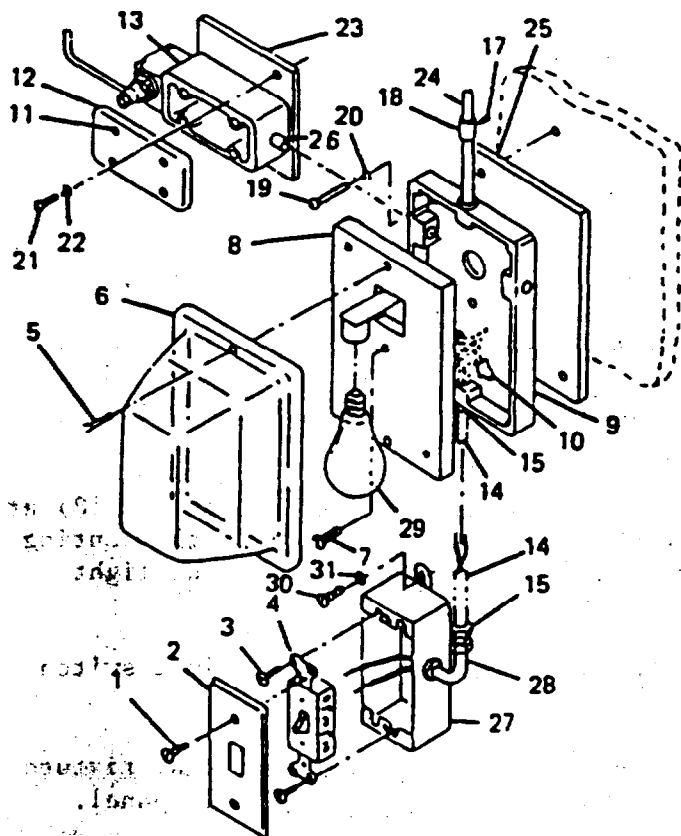

PRIOR TO S/N 1089

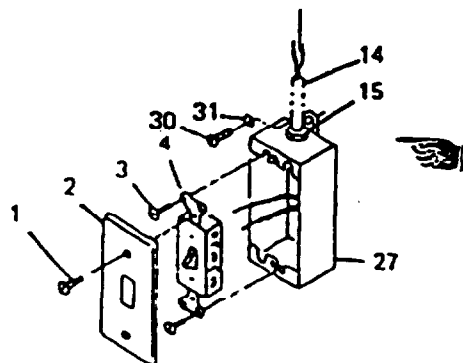

S/N 1089 AND SUBSEQUENT

4-10. (cont)

16. Position switch (4) in outlet box (27) and secure with two screws (3).
17. Position switch cover (2) on switch (4) and secure with two screws (1).
18. Position light fixture (8) near light fixture adapter (9) and connect wires. (Refer to paragraph 4-46)
19. Position light fixture (8) on light fixture adapter (9) and secure with one screw (7). Install bulb (29).
20. Position light fixture cover (6) on light fixture (8) and secure with two screws (5).

4-11. HINGED ROOF AREA CEILING LIGHT TESTING AND REPAIR

This task covers:

- | | |
|-------------------------|-------------|
| a. Testing | d. Repair |
| b. Disassembly | e. Assembly |
| c. Cleaning, Inspection | |

INITIAL SETUP

Special Tools

Hand blind riveter, Appendix B, Item 2

Test Equipment

Multimeter, Appendix B, Item 4

Standard Tools

General mechanics tool kit

Personnel

Electrician

Equipment Condition

Hinged roof area ceiling light removed (paragraph 3-5) All circuit breakers and switches in OFF position

TESTING

WARNING

In the event of lamp breakage, care must be taken in the removal of broken glass fragments and white phosphorus dust that may be dispersed within the fixture. Inhalation of phosphorus dust could cause dangerous injury. Set all circuit breakers and switches to OFF position.

4-11. (cont)

1. Remove three screws (1) and cover (2).
2. Using multimeter, check for continuity at fluorescent lamps, ballast and electrical cord.
3. If no continuity is present, replace defective fluorescent lamp, ballast or electrical cord.

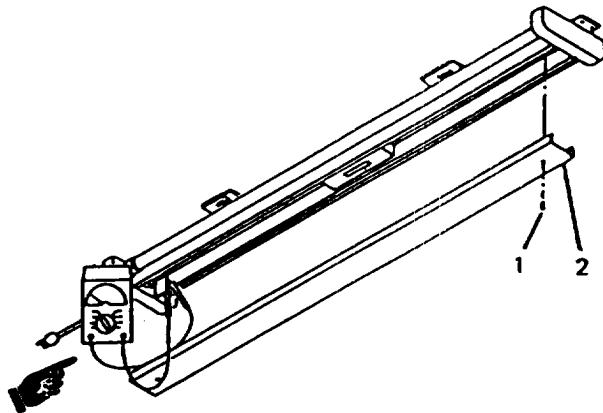

DISASSEMBLY

1. Remove screws (1) and cover (2) from light frame (6).

CAUTION

When removing end caps, hold safety tube level to prevent fluorescent tube from accidentally sliding out and dropping.

2. Remove split retaining rings (3) from one end of fluorescent lamps (4).
3. Remove two fluorescent lamps (4) with light shields (5) by rotating and sliding out of light frame (6). Remove light shields (5) from fluorescent lamps (4).
4. Tag all wires and remove wire nuts (7).
5. Separate all connecting wires to the ballast (15), electrical cord, and light frame (6).

4-11. (cont)

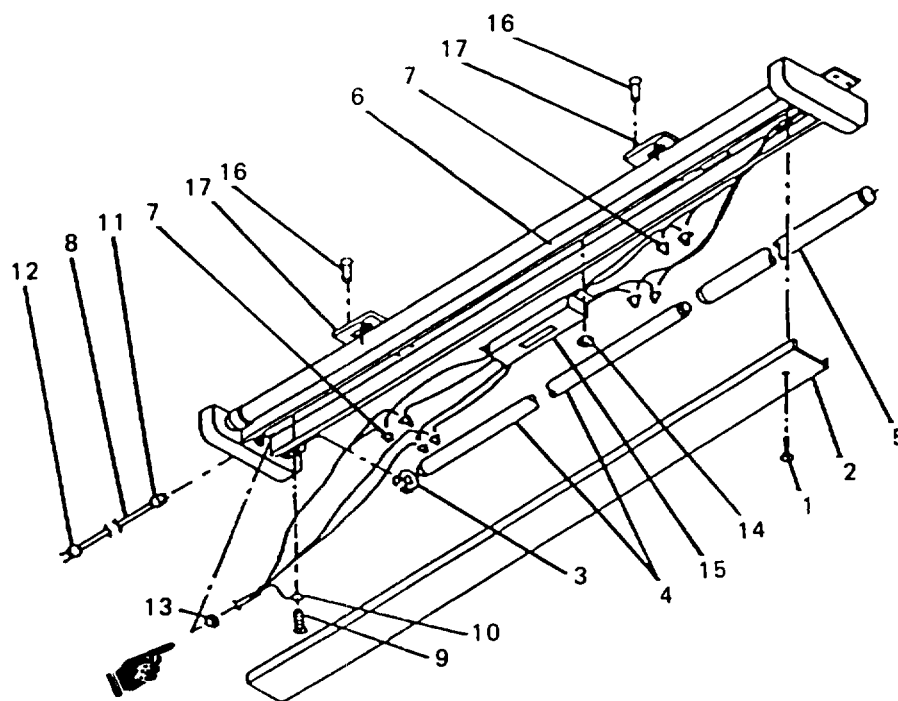

6. Remove installation screw (9) attaching terminal lug (10) on third wire from electrical cord (8).
7. Remove locknut (13) and remove electrical cord (8) with liquid tight connector (11) and plug (12) from light frame (6).
8. Remove nuts (14) and remove ballast (15) from light frame (6).
9. Drill out rivets (16) and remove two light support plates (17) from light frame (6). (Refer to paragraph 4-32)

CLEANING, INSPECTION

1. Clean hinged roof area ceiling light and component surfaces.

NOTE

Do not use water to clean hinged roof area ceiling lights.

2. Inspect mounting surfaces for corrosion and damage.

4-11. (cont)

3. Inspect for and replace if necessary:
 - a. Hissing or damaged components.
 - b. Corrosion or paint damage.

REPAIR

Repair corrosion or paint damage. (Refer to paragraph 4-43)

ASSEMBLY

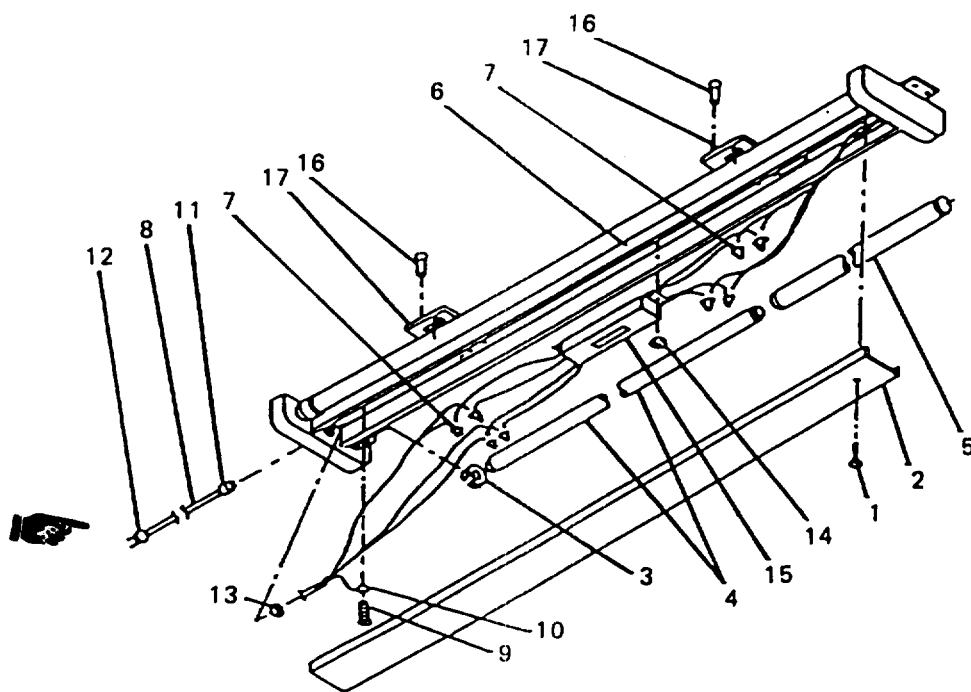

1. Position two light support plates (17) on light frame (6) and install rivets (16). (Refer to paragraph 4-32)
2. Position ballast (15) in light frame (6) and secure with nuts (14).
3. Install electrical cord (8) with liquid tight connector (11) and plug (12).
4. Attach terminal lug (10) of electrical cord (8) and secure with installation screw (9).
5. Connect all wires and secure with wire nuts (7) and remove all tags.

4-11. (cont)

CAUTION

When installing end caps, hold safety tube level to prevent fluorescent tube from accidentally sliding out and dropping.

6. Assemble light shields (5) on fluorescent lamps (4) and install in light frame (6) by sliding in and rotating.
7. Install split retaining rings (3) on end of fluorescent lamps (4).
8. Attach cover (2) to light frame (6) with screws (1).

NOTE

Replace hinged roof area ceiling light in accordance with paragraph 3-5. Place all circuit breakers to the ON position.

4-12. FIXED ROOF AREA CEILING LIGHT TESTING, REPLACEMENT, AND REPAIR

This task covers:

- | | |
|-------------------------|-----------------|
| a. Testing | e. Repair |
| b. Removal | f. Assembly |
| c. Disassembly | g. Installation |
| d. Cleaning, Inspection | |

INITIAL SETUP

Special Tools

Hand blind riveter, Appendix B, Item 2

Test Equipment

Multimeter, Appendix B, Item 4

Standard Tools

General mechanics tool kit

Personnel

Electrician

Equipment Condition

All circuit breakers and switches in OFF position

4-12. (cont)
TESTING

1. Remove three screws (1) and cover (2).
2. Using multimeter, check for continuity of fluorescent lamps, ballast, and wiring.
3. no continuity is present, replace defective fluorescent lamp, ballast, or wiring.

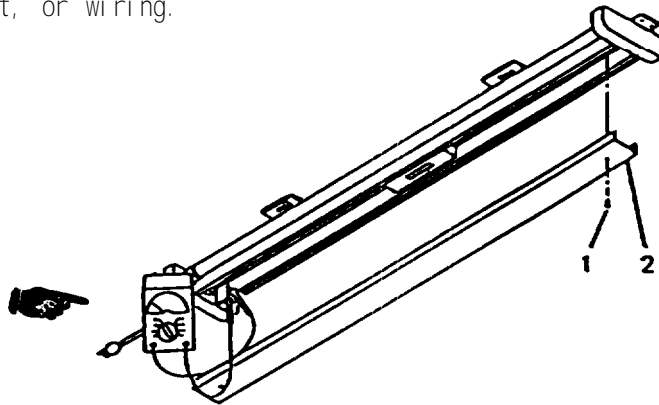

WARNING

This fixture contains voltage that is dangerous if contacted. Before replacing fixed roof area ceiling light, set all circuit breakers and switches to OFF position.

REMOVAL

1. Remove three screws (1) and cover (2) from fixed roof area ceiling light (3).

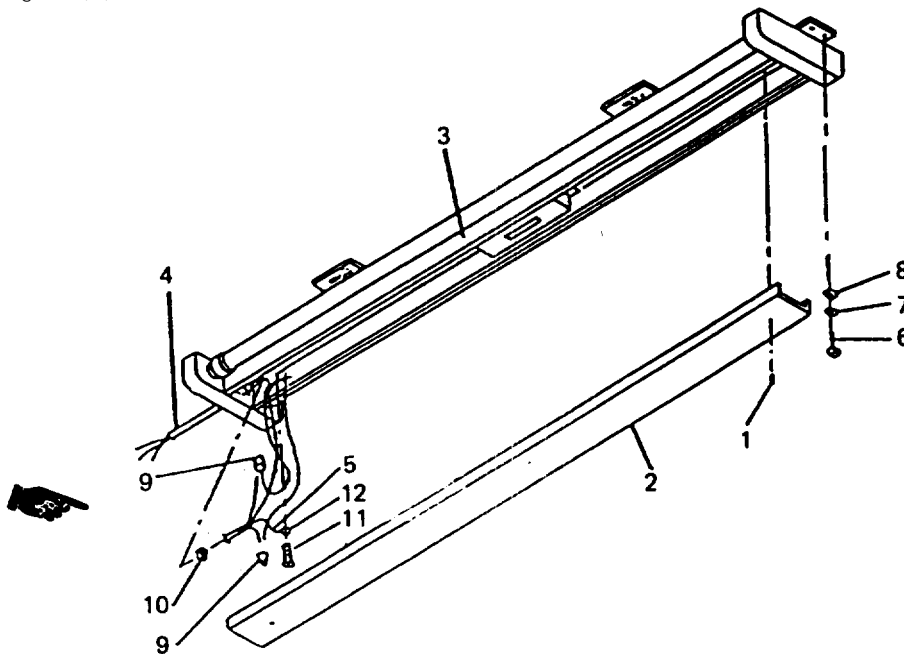

4-12. (cont)

NOTE

Tag wires for reconnection.

2. Remove wire nuts (9), separate conduit wiring.
3. Remove installation screw (11) attaching terminal lug (12) on third wire (5) from conduit (4).
4. Loosen locknut (10), and separate conduit (4) and its wiring from fixed roof area ceiling light.
5. Remove four screws (6), lockwashers (7), and washers (8), and remove fixed roof area ceiling light (3) from fixed roof.

WARNING

In the event of lamp breakage, care must be taken in the removal of broken glass fragments and white phosphorus dust that may be dispersed within the fixture. Inhalation of phosphorus dust could cause serious injury.

DISASSEMBLY

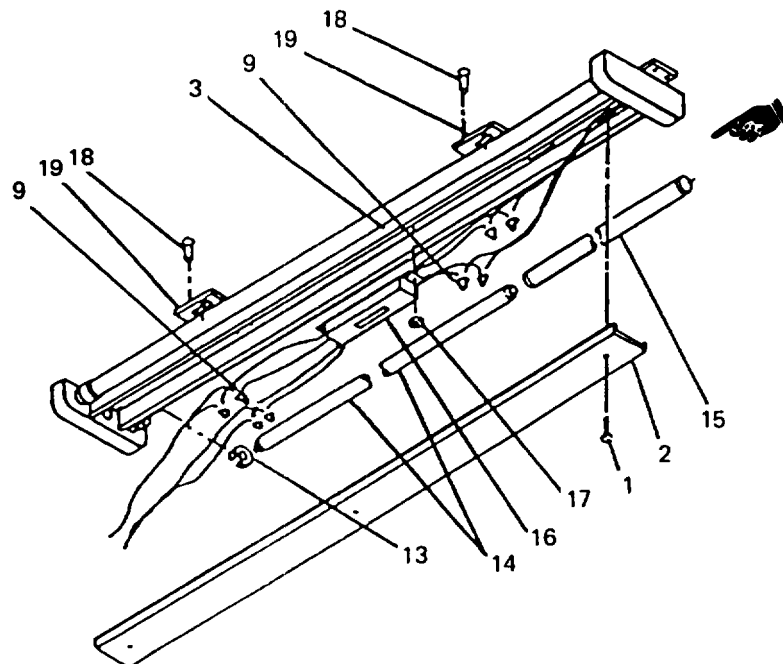

1. Remove screws (1) and cover (2) from light frame (3).

4-12. (cont)

CAUTION

When removing end caps, hold safety tube level to prevent fluorescent tube from accidentally sliding out and dropping.

2. Remove split retaining rings (13) from one end of fluorescent lamps (14).
3. Remove two fluorescent lamps (14) with light shields (15) by rotating and sliding out of light frame (3). Remove light shields (15) from fluorescent lamps (14).

NOTE

Tag all wires for reconnection.

4. Remove two wire nuts (9) and separate two sets of wires between ballast (16) and contacts on light frame (3).
5. Remove four wire nuts (9) and separate four sets of wires between ballast (16) and contacts at opposite end of light frame (3).

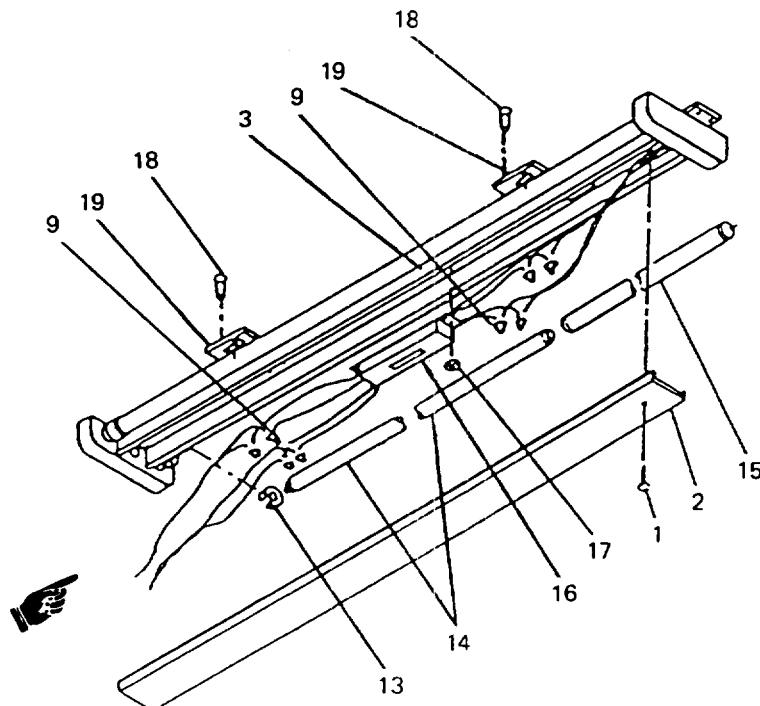

4-12. (cont)

6. Remove nuts (17) and remove ballast (16) from light frame (3).
7. Drill out rivets (18) and remove two light support plates (19) from light frame (3). (Refer to paragraph 4-32)

CLEANING, INSPECTION

1. Clean hinged roof area ceiling light and component surfaces.
2. Inspect mounting surfaces for corrosion and damage.
3. Inspect for and replace if necessary:
 - a. Missing or damaged components.
 - b. Corrosion or paint damage.

REPAIR

Repair corrosion or paint damage. (Refer to paragraph 4-43)

ASSEMBLY

1. Position two light support plates (19) on light frame (3) and install rivets (18). (Refer to paragraph 4-32)
2. Position ballast (16) in light frame (3) and secure with nuts (17).
3. Connect two wires from ballast (16) to contacts on light frame (3) as follows:

Yellow to Yellow
Yellow to Black
4. Connect four wires from ballast (16) to contacts at opposite end of light frame (3) as follows:

Red to Black
Red to Black
Blue to White
Blue to White

4-12. (cont)

7. Secure all wires with wire nuts (9),
8. Assemble light shields (15) on fluorescent lamps (14) and install in light frame (3) by sliding in and rotating.
9. Install split retaining rings (13).
10. Attach cover (2) to light frame (3) with screws (1).

INSTALLATION

1. Position fixed roof area ceiling light (3) against fixed roof and install washers (8), lockwashers (7), and screws (6).
2. Pull wires from conduit (4) into fixed roof area ceiling light (3) and connect two wires to two wires from light ballast (16) as follows:

 Black to Black
 White to Yellow/Green
3. Secure wires with wire nuts (9).
4. Attach terminal lug (12) on end of green wire (5) to fixed roof area ceiling light (3) with installation screw (11).
5. Attach conduit (4) to fixed area ceiling light (3) with locknut (10).
6. Attach cover (2) to fixed roof area ceiling light (3) with screws (1).

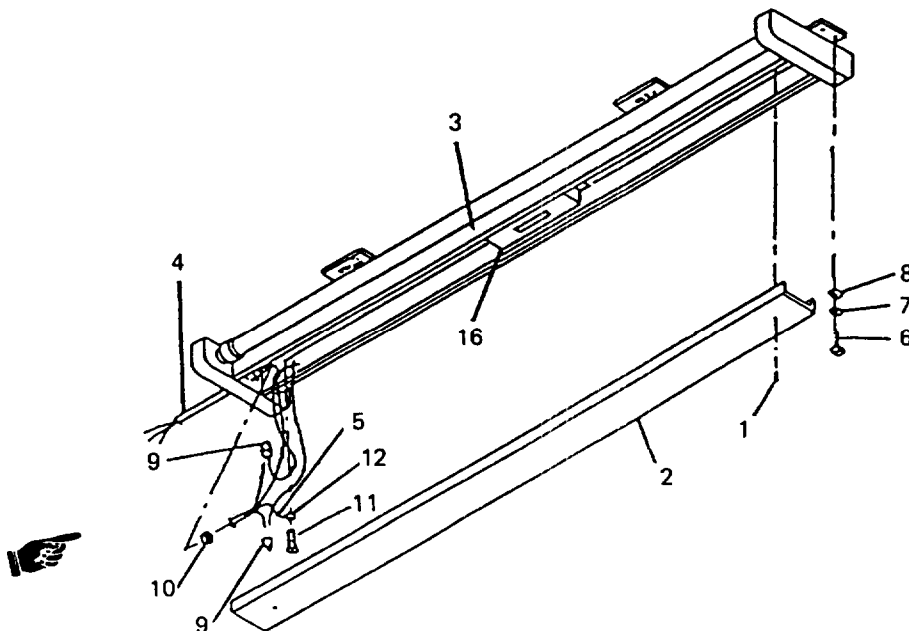

4-13. RECEPTACLE OUTLETS TESTING, REPLACEMENT, AND REPAIR

This task covers:

- | | |
|-------------------------|-----------------|
| a. Testing | e. Repair |
| b. Removal | f. Assembly |
| c. Disassembly | g. Installation |
| d. Cleaning, Inspection | |

INITIAL SETUP

Special Tools

Installation tool, Appendix B, Item 9
Electrical tool kit, Appendix B, Item 5

Standard Tools

General mechanics tool kit

Test Equipment

Multimeter, Appendix B, Item 4

Personnel

Electrician
Sheet metal worker

WARNING

Remove all electrical power from circuits before removing cable and receptacle assemblies.

TESTING

1. Set all circuit breakers to OFF position.
2. Using multimeter, check for continuity in cable and receptacle assemblies.

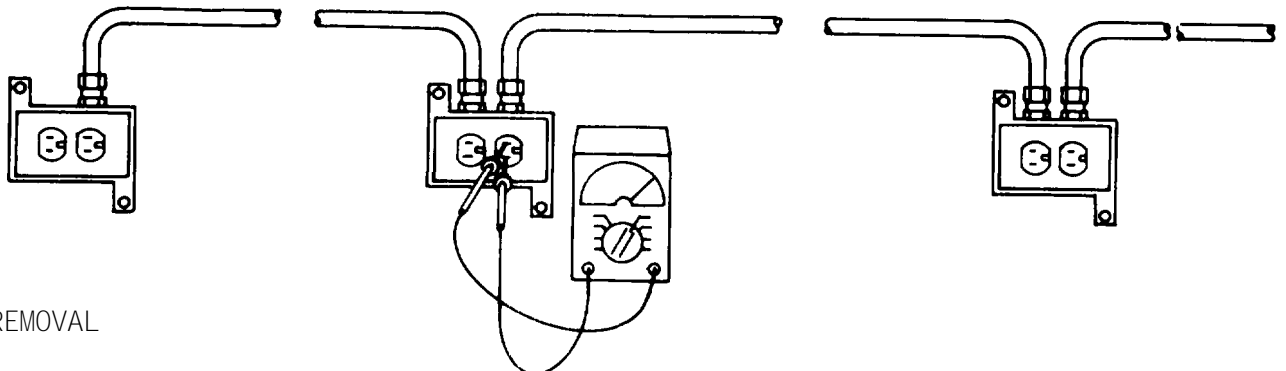

REMOVAL

1. Open velcro straps (1) securing electrical cords (2) to walls.

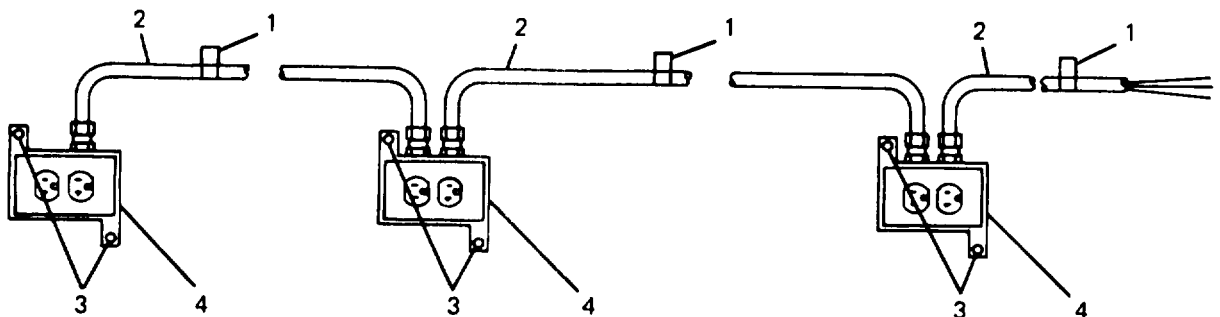

4-13. (cont)

2. Disconnect wires from cable and receptacle assemblies at circuit breakers CB3, CB5, and CB7. (Refer to paragraph 4-46 and 4-47)

NOTE

Tag wires for reconnection

3. Using screwdriver, back out two captive screws (3) on each junction box assembly (4) and remove cable and receptacle assemblies from walls.

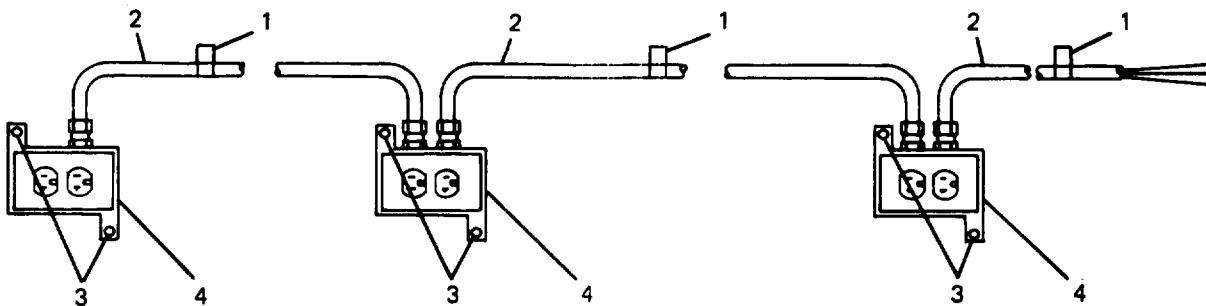

DISASSEMBLY

1. Remove screws (1) and duplex covers (2).
2. Remove screws (3) and duplex receptacles (4) from junction boxes (5) as far as they will go.
3. Remove wire nuts (8) and terminals, and disconnect wires from rear of receptacles (4), where applicable.

NOTE

Tag wires for reconnection

4. Remove liquid tight connectors (6) from junction boxes (5) and separate connectors from electrical cords (7).
5. Remove captive screws (9) from junction boxes (5).

4-13. (cont)

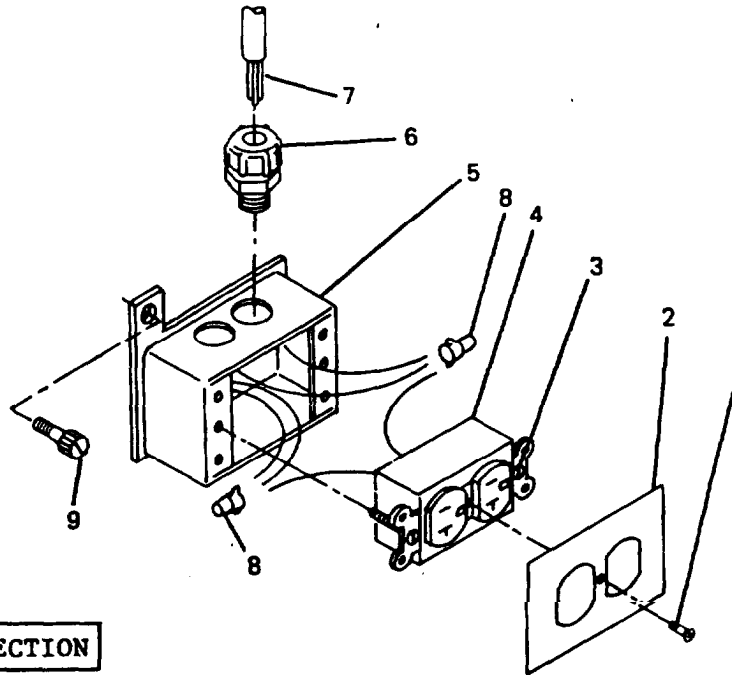

CLEANING, INSPECTION

1. Clean cable and receptacle assembly and component surfaces.
2. Inspect mounting surfaces for corrosion and damage.
3. Inspect for and replace if necessary:
 - a. Missing or damaged components.
 - b. Corrosion or paint damage.

REPAIR

1. Repair or replace damaged wiring.
2. Corrosion or paint damage. (Refer to para. 4-43)

ASSEMBLY

1. Using installation tool, install captive screws (9) in junction boxes (5).
2. Assemble liquid tight connectors (6) on electrical cords (7).
3. Install liquid tight connectors (6) in junction boxes (5).
4. Connect wires to receptacles (4) and attach wire nuts (8) and terminals, where applicable. (Refer to paragraph 4-46)
5. Position receptacles (4) on junction boxes (5) and install screws (3).
6. Position covers (2) on duplex receptacles (4) and install screws (1).

4-13. (cont)

INSTALLATION

1. Position cable and receptacle assemblies against walls with power cord facing up and secure junction box assemblies (4) by using screwdriver and tightening two captive screws (3) on each box.
2. Connect wires from cable and receptacle assemblies to circuit breakers CB3, C85, and CB7. (Refer to paragraph 4-46)
3. Secure electrical cords (2) to walls with velcro straps (1).

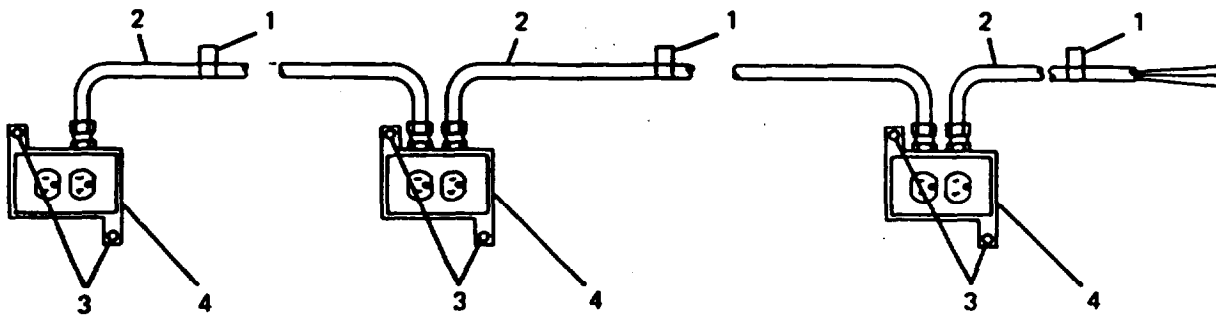

4-14. WALL SWITCH REPLACEMENT

This task covers:

- a. Removal
- b. Installation

INITIAL SETUP

Standard Tools

General mechanics tool kit

Personnel

Electrician

REMOVAL

1. Set all circuit breakers and switches to OFF position.
2. Remove two screws (1) and switch cover (2).
3. Remove two screws (3) and carefully pull wall switch (4) out of switch box (5) as far as it will go.
4. Disconnect wires from wall switch (4).
5. Remove two screws (6) and lo&washers (7) and remove switch box (5) from wall.

4-14. (cont)

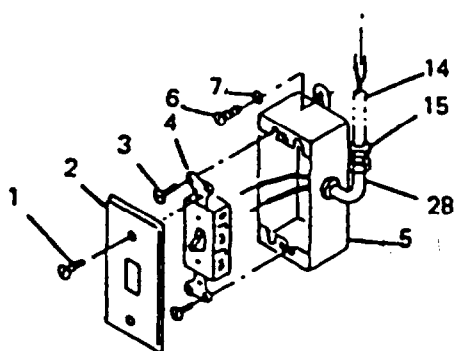

PRIOR TO S/N 1089

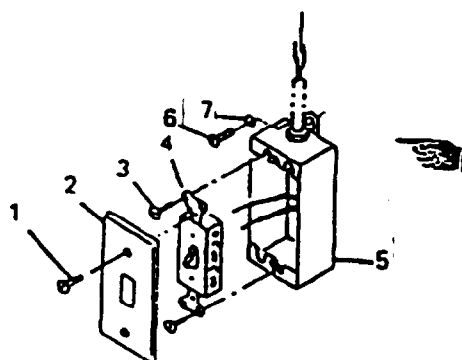

S/N 1089 AND SUBSEQUENT

INSTALLATION

1. Position switch box (5) on wall and secure with two lo&washers (7) and screws (6).
2. Position wall switch (4) near switch box (5) and connect wires to rear of switch. (Refer to paragraph 4-46.)
3. Position wall switch (4) in switch box (5) and secure with two screws (3).
4. Position switch cover (2) against switch box (5) and secure with two screws (1).

4-15. BLACKOUT SWITCH REPLACEMENT, REPAIR, AND ADJUSTMENT

This task covers:

- | | |
|-------------------------|-----------------|
| a. Removal | d. Installation |
| b. Cleaning, Inspection | e. Adjustment |
| c. Repair | |
-

INITIAL SETUP

Standard Tools

General mechanics tool kit

Personnel

Electrician

4-15. (cont)

REMOVAL

1. Remove two screws (1) and switch cover (2).
2. Remove two screws (3) and pull switch (4) from outlet box (27) as far as it will go.

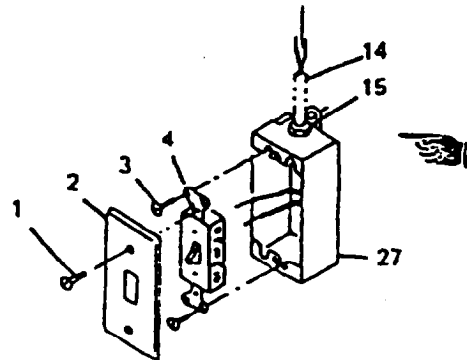
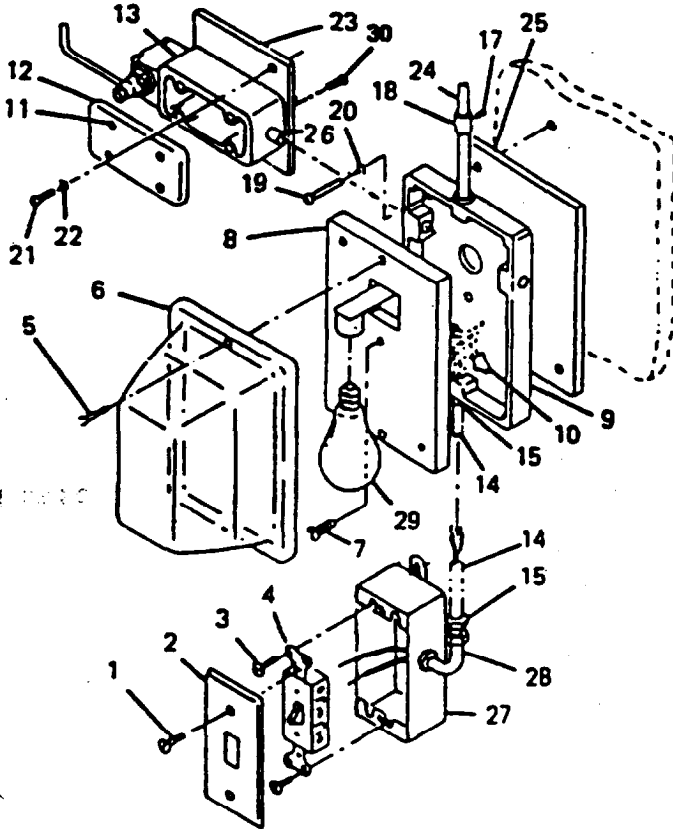

PRIOR TO S/N 1089

S/N 1089 AND SUBSEQUENT

3. Disconnect wires at rear of switch (4).

NOTE

Tag wires for reconnection.

4. Remove two screws (5) and light fixture cover (6). Remove bulb (29).
5. Remove screw (7) and separate light fixture (8) from light fixture adapter (9) as far as it will go.
6. Remove wire nuts (10) and disconnect wires from rear of light fixture (6).

4-15. (cont)

NOTE

Tag wires for reconnection.

7. Loosen four captive screws (11) and remove limit switch cover (12).
- a. Disconnect three sets of wires plus one ground wire inside limit switch (13).

NOTE

Tag wires for reconnection.

9. Pull individual wires up through lower conduit (14) and into light fixture adapter (9).
10. Loosen two insulating connectors (15) below light fixture adapter (9) and:
 - a. For units prior to S/N 1069, loosen insulating conduit connector (15) at elbow (26) and remove conduit (14).
 - b. For units with S/N 1069 and subsequent, loosen insulating conductor (15) at switch box (27) and remove conduit (14).
11. Loosen screw (17) at rear of offset connector (1a).
12. Remove two screws (19) and lockwashers (20) from light fixture adapter (9).
13. Remove two screws (21) and lockwashers (22) from limit switch mounting plate (23).
14. Lower light fixture adapter (9) together with limit switch (13) and limit switch mounting plate (23) from upper conduit (24).
15. Remove incandescent light spacer (25).
16. Separate light fixture adapter (9) from limit switch (13) and limit switch mounting plate (23) by unscrewing close nipple (26).
17. Remove two screws (30) and separate limit switch (13) from limit switch mounting plate (23).

CLEANING, INSPECTION

1. Clean blackout switch and component surfaces.
2. Inspect mounting surfaces for corrosion and damage.
3. Inspect for and replace if necessary:
 - a. Missing or damaged components.
 - b. Corrosion or paint damage.

4-15. (cont)

REPAIR

Corrosion or paint damage. (Refer to paragraph 4-43)

INSTALLATION

1. Assemble light switch (13) to limit switch mounting plate (23) with two screws (30).
2. Assemble light switch (13) with limit switch mounting plate (23) to light fixture adapter (9) using close nipple (26).
3. Pass wiring through close nipple (26) into limit switch (13).
4. Connect wiring. (Refer to paragraph 4-46.)
5. Position limit switch cover (12) on limit switch (13) and tighten four captive screws (11).
6. Pass wiring from upper conduit (24) through offset connector (18) at top of light fixture adapter (9) and position limit switch mounting plate (23) and light fixture adapter (9) with incandescent light spacer (25) behind it against endwall panel.

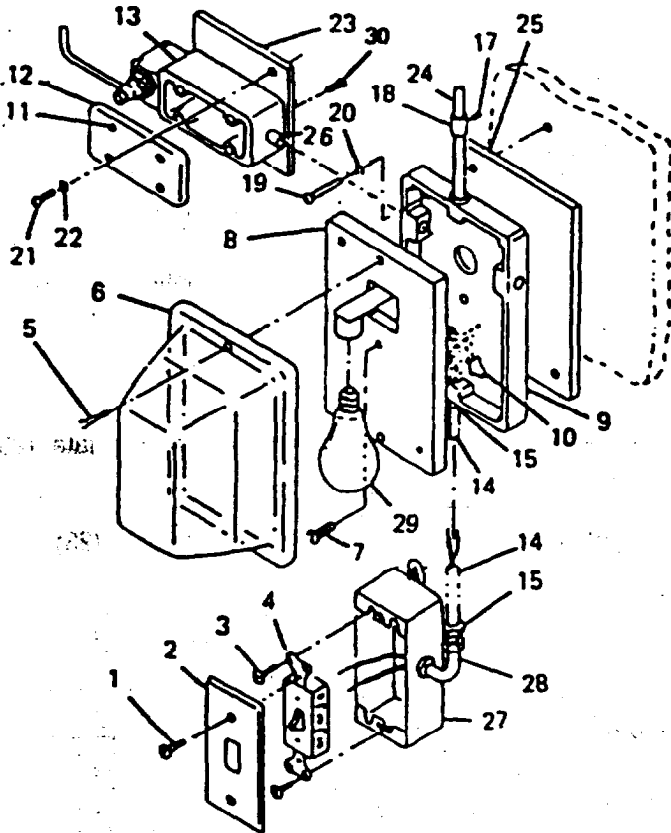

PRIOR TO S/N 1089

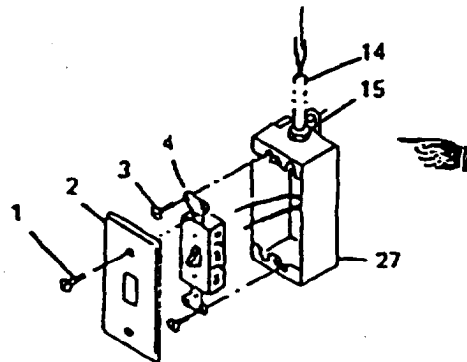

S/N 1089 AND SUBSEQUENT

7. Install two screws (21) and lockwashers (22) securing limit switch (13) and limit switch mounting plate (23) to endwall panel.

4-15. (cont)

8. Install two screws (19) and lockwashers (20) securing light fixture adapter (9) and incandescent light spacer (25) to endwall panel.
9. Pull wiring down into light fixture adapter (9), position offset connector (18) at top of adapter, and tighten.
10. Tighten screw (17) at rear of offset connector (18).
11. Pass wiring for switch (4) through lower hole of light fixture adapter (9) and thread through lower conduit (14).
12. Position lower conduit (14) in hole at bottom of light fixture adapter (9).
13. Pull wiring through conduit (14) and:
 - a. For units prior to S/N 1089, pull wiring through elbow connector (28) and into outlet box (27).
 - b. For units with S/N 1089 and subsequent, pull wiring into outlet box (27).
14. Position lower conduit (14) into:
 - a. Elbow connector (28) (for units prior to S/N 1089) and tighten lower insulating connector (15).
 - b. Conduit outlet box (27) (for units with S/N 1089 and subsequent) and tighten lower insulating connector (15).
15. Position switch (4) near outlet box (27) and connect wires. (Refer to paragraph 4-46)
16. Position switch (4) in outlet box (27) and secure with two screws (3).
17. Position switch cover (2) on switch (4) and secure with two screws (1).
18. Position light fixture (8) near light fixture adapter (9) and connect wires using wire nuts (10). (Refer to wire list.)
19. Position light fixture (8) on light fixture adapter (9) and secure with screw (7). Install bulb (29).
20. Position light fixture cover (6) on light fixture (8) and secure with two screws (5).

ADJUSTMENT

There are three possible adjustments which can be made on the blackout switch.

1. Bend limit switch arm (1) towards or away from the endwall panel.

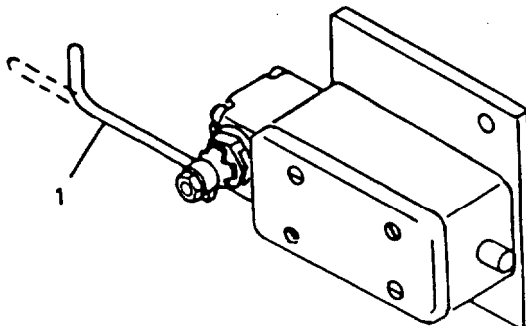

4-15. (cont)

2. Loosen two setscrews (2) and slide limit switch arm (1) in or out of collar (3).
3. Loosen nut (4) and rotate collar (3) with limit switch arm (1) up or down.

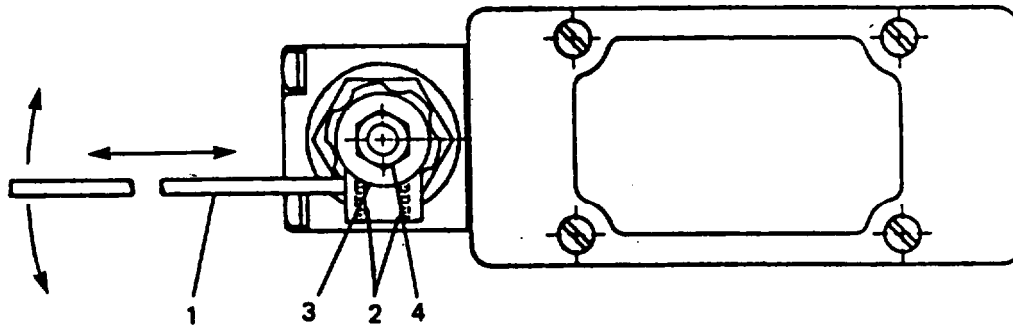

4-16. WIRING TESTING, REPLACEMENT, AND REPAIR

This task covers:

- | | |
|-------------------------|-----------------|
| a. Testing | e. Repair |
| b. Removal | f. Assembly |
| c. Disassembly | g. Installation |
| d. Cleaning, Inspection | |

INITIAL SETUP

Special Tools

Hand blind riveter, Appendix B, Item 2
Electrical tool kit, Appendix B, Item 5

Standard Tools

General mechanics tool kit

Test Equipment

Multimeter, Appendix B, Item 4.

Personnel - 4

Electrician

Equipment Condition

Hinged roof area ceiling
lights removed, paragraph
3-5

WARNING

Wiring in roof beams contains voltage that is dangerous if contacted. Before replacing wiring, make sure all circuit breakers and switches are set to OFF position.

4-16. (cont)

TESTING

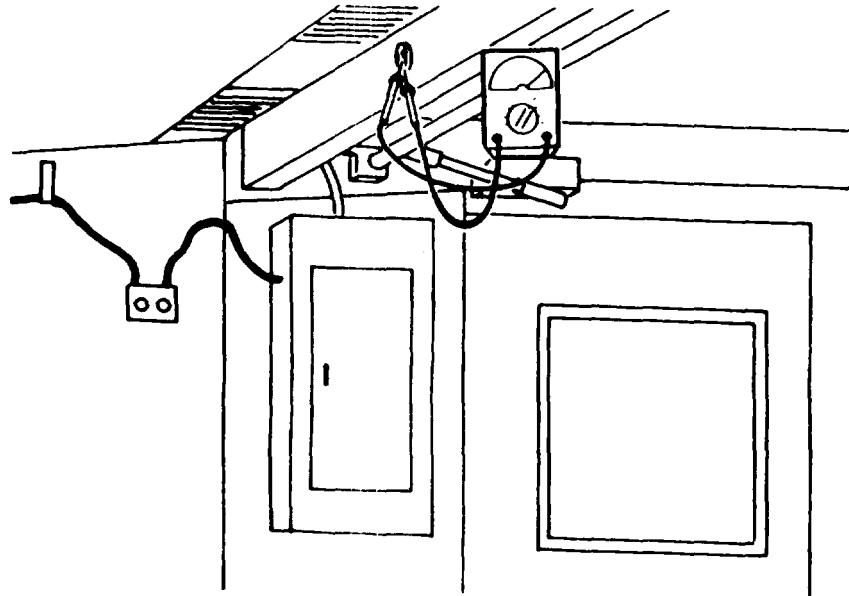

1. Set all circuit breakers and switches to OFF position.
2. Using multimeter, check for continuity at outlet receptacles and wiring in roof beams.
3. If no continuity is present, replace defective outlet receptacles or wiring in roof beams.

NOTE

Left and right side roof beams are identified looking toward personnel door from inside shelter.

REMOVAL

Right Side Roof Beam Wiring

1. Remove four screws (1) and remove junction box cover (2) from junction box (3).
2. Disconnect wires from right side roof beam (4) in junction box (3).

4-16. (cont)

NOTE

Tag wires for reconnection.

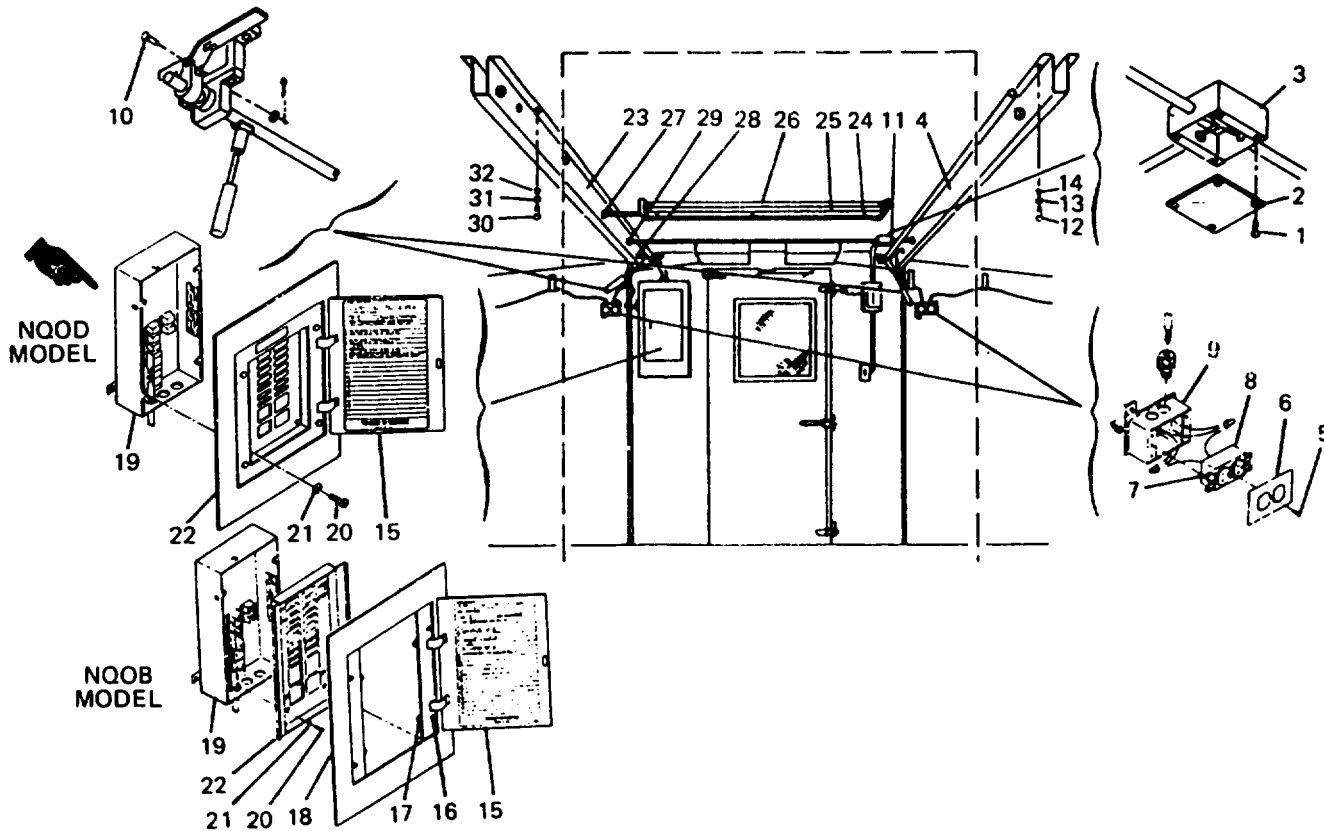

3. Remove screw (5) and receptacle cover (6) at each end of right side roof beam (4).
4. Remove four screws (7) and two receptacles (8) from two outlet boxes (9) as far as they will go.
5. Disconnect wires from right side roof beam (4) at rear of two receptacles (8).

NOTE

Tag wires for reconnection.

4-16. (cont)

6. Remove three push bar assembly pins (10).
7. Loosen conduit locknuts (11) between junction box (3) and right side roof beam (4).
8. Remove bolts (12), lockwashers (13), and washers (14) from right side roof beam (4).
9. Remove right side roof beam (4) from roof panel.

Left Side Roof Beam Wiring

NOTE

This portion of the procedure is applicable to both models of circuit breaker panels. Older models (NQOB) allow individually removing the panel cover or the panelboard. Newer model (NQOD) has the panel cover and panelboard attached and is removed as a single unit.

10. Open circuit breaker panel doors (15).
11. On model NQOB, loosen four captive screws (16) and move four clamp fingers (17) to the open position.
12. On model NQOB, lift panel cover (18) from the circuit breaker panel board (22).
13. On both models, remove four screws (20) and washers (21) and lift panel board (22) from circuit breaker box (19).
14. Disconnect wires from left side roof beam (23) in circuit breaker box (19).

NOTE

Tag wires for reconnection.

4-16. (cont)

15. Remove four screws (1) and remove junction box cover (2) from junction box (3).
16. Disconnect wires from left side roof beam (12) in junction box (3).

NOTE

Tag wires for reconnection.

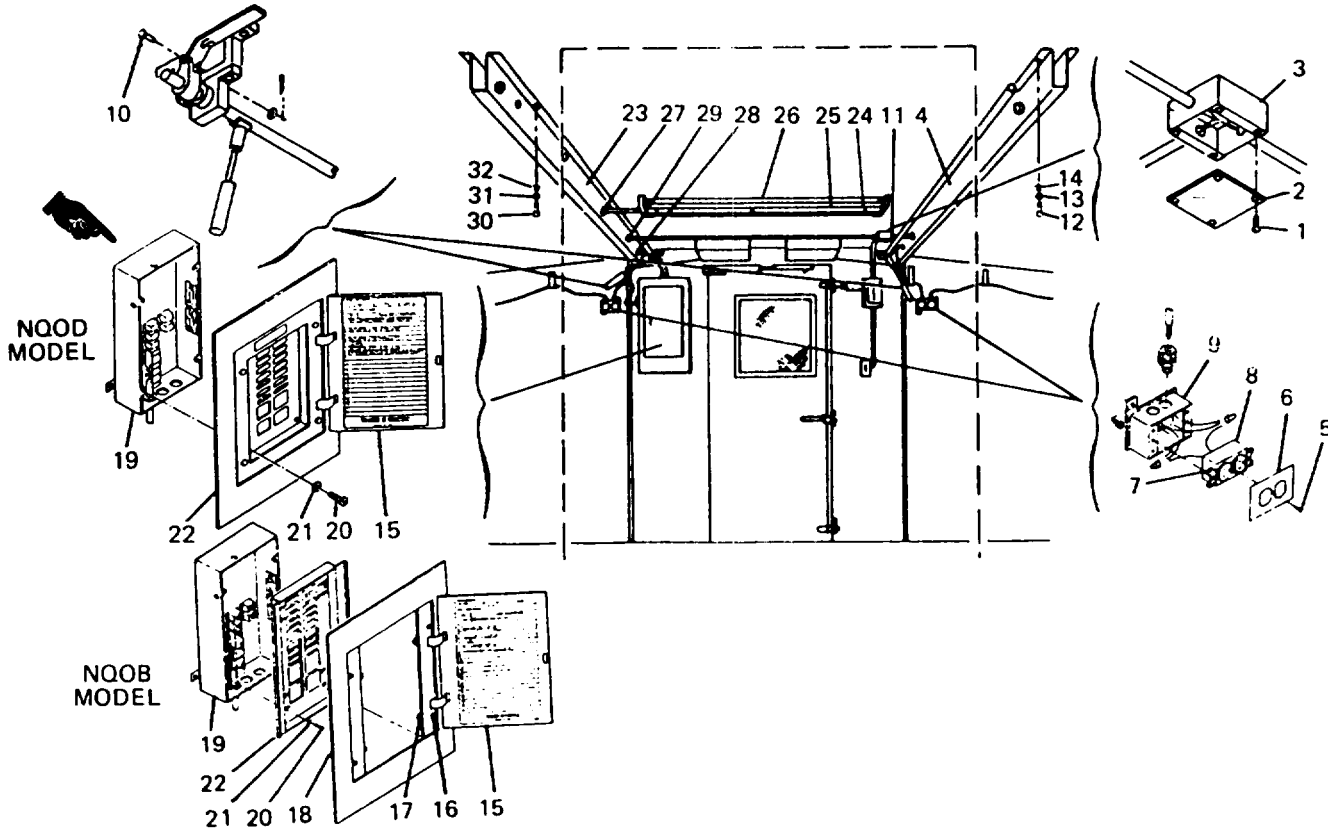

17. Remove nine screws (24) and three fixed roof area ceiling light covers (25).
18. Disconnect wires from left side roof beam (23) in each of three fixed roof area ceiling lights (26).

NOTE

Tag wires for reconnection. Perform next three steps at cargo door end.

4-16. (cont)

19. Remove screw (5) and receptacle cover (6).
20. Loosen two captive screws (7) and remove receptacle (8) from outlet box (9) as far as it will go.
21. Disconnect wires from left side roof beam (23) at rear of receptacle (8).
22. Disconnect conduit locknuts (27) at roof beam area between left side roof beam (23) and each of three fixed roof area ceiling lights (26).
23. Disconnect conduit locknut (28) at roof beam area between left side roof beam (23) and top of circuit breaker box (19).
24. Disconnect conduit locknut (29) at roof beam area between left side roof beam (23) and junction box (3).
25. Remove push bar assembly pins (10) at each of three push bar assemblies.
26. Remove bolts (30), lockwashers (31), and washers (32) from left side roof beam (23).
27. Remove left side roof beam (23) from roof panel.

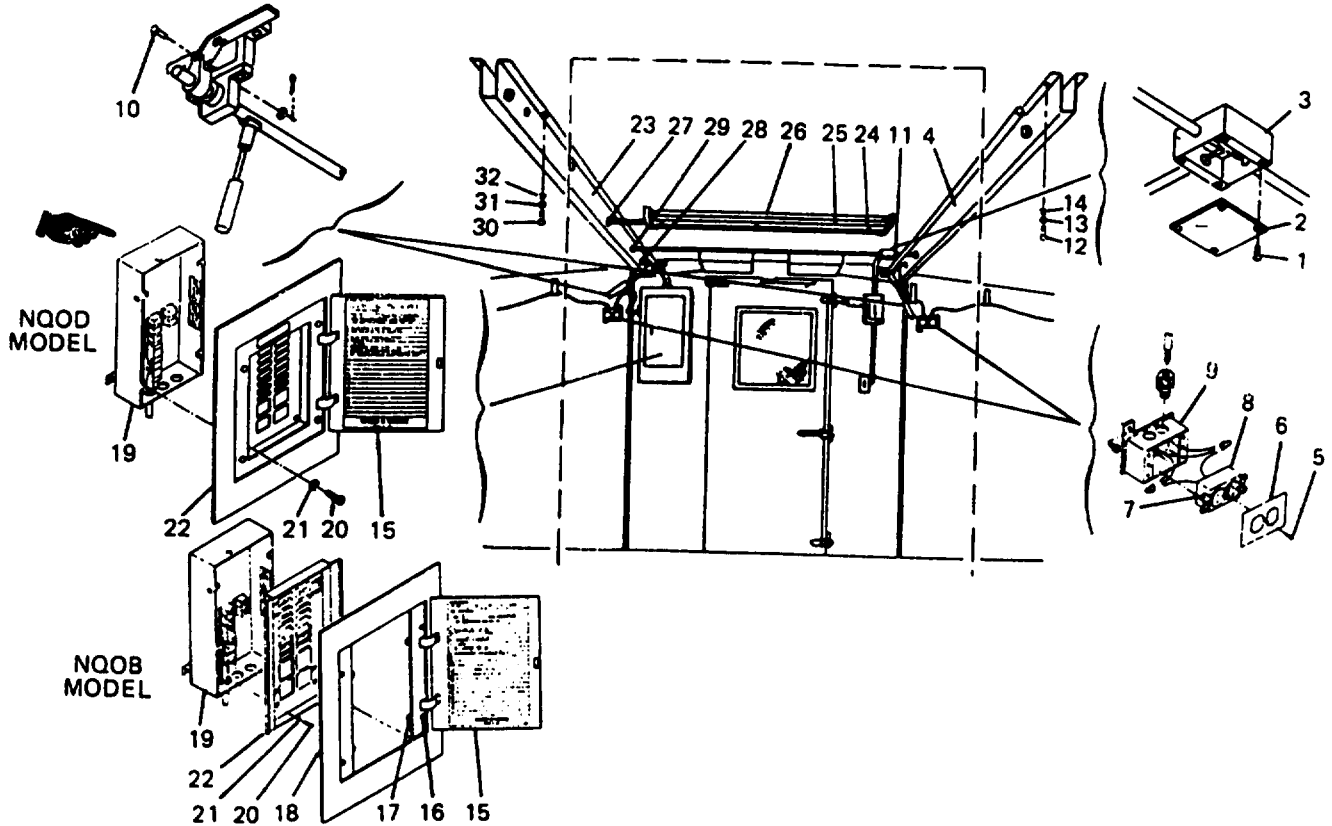

4-16. (cont)

DISASSEMBLY

Right Side Roof Beam Assembly

1. Remove nine wire nuts (1), and four cable ties (2).
2. Remove six screws (4), nuts (5), lockwashers (6), and three receptacles (7) from right side roof beam (13).
3. Remove two liquid tight connectors (8) and locknuts (9).
4. Remove electrical cord (10) and connector (11).
5. Remove wires (12) from receptacles (7).

NOTE

Tag wires for reconnection.

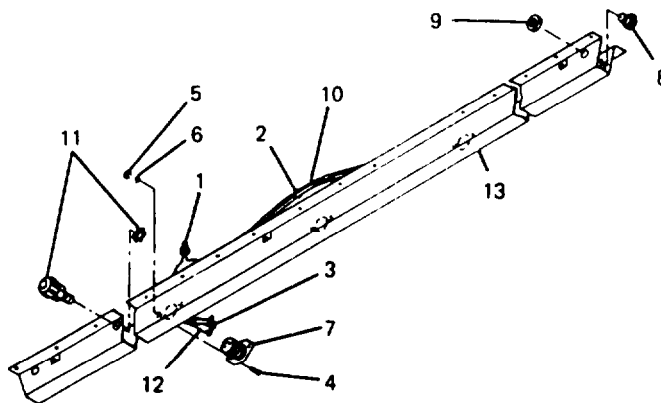

Left Side Roof Beam Assembly

6. Remove twenty-four wire nuts (14), twenty cable ties (15), and eleven terminal lugs (16).
7. Remove six screws (17), nuts (18), lockwashers (19), and three receptacles (20) from left side roof beam (27).
8. Remove liquid tight connector (21) and locknut (22).
9. Remove three insulated connectors (23), two connectors (24), and electrical cord (25).
10. Remove wires (26) from receptacles (20).

4-16. (cont)

NOTE

Tag wires for reconnection.

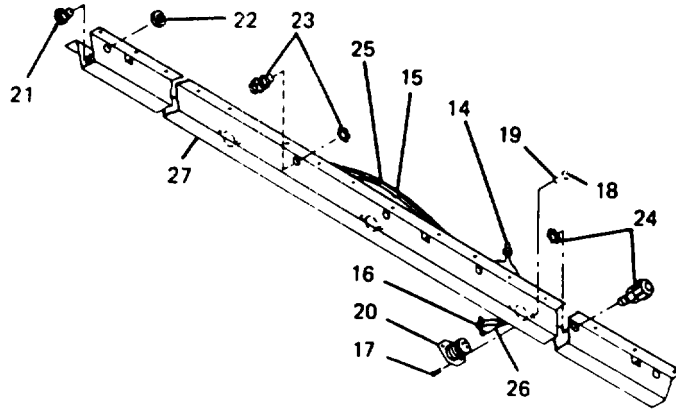

CLEANING, INSPECTION

1. Clean left and right side roof beam assemblies and components.
2. Inspect mounting surfaces for corrosion and damage.
3. Inspect for and replace if necessary:
 - a. Missing or damaged components.
 - b. Corrosion or paint damage.

REPAIR

1. Replace damaged wiring.
2. Corrosion or paint damage, (Refer to paragraph 4-43)

4-16. (cont)

ASSEMBLY

Left Side Roof Beam Assembly

1. Connect wires (26) to receptacles. (Refer to paragraph 4-46)
2. Install three insulated connectors (23), two connectors (24), and electrical cord (25) in left side roof beam (27).
3. Install liquid tight connector (21) and locknut (22) in left side roof beam (27).
4. Install three receptacles (20) in left side roof beam (27) and secure with six screws (17), nuts (18), and lockwashers (19).
5. Attach twenty-four wire nuts (14), twenty cable ties (15), and eleven terminal lugs (16).

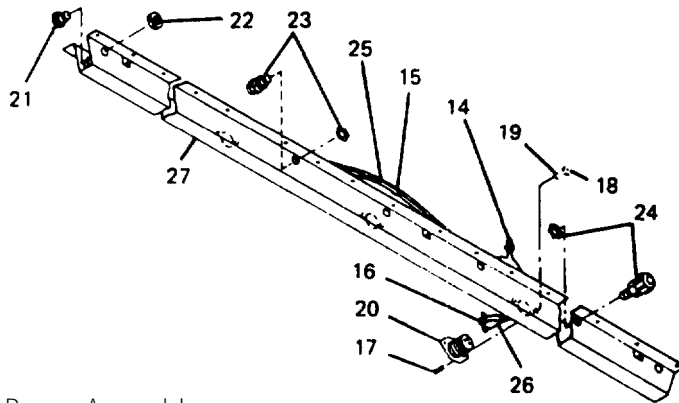

Right Side Roof Beam Assembly

6. Connect wires (12) to receptacles (7). (Refer to paragraph 4-46)
7. Install electrical cord (10) and connector (11).

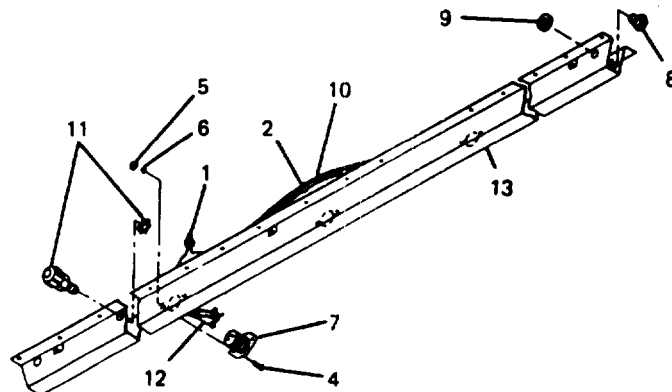

4-16. (cont)

8. Install two liquid tight connectors (8) and locknuts (9).
9. Install three receptacles (7) in right side roof beam (13) and secure with six screws (4), nuts (5), and lockwashers (6).
10. Attach nine wire nuts (1), and four cable ties (2).

INSTALLATION

NOTE

Position left side roof beams are identified by looking toward personnel door from inside shelter.

Left Side Roof Beam Wiring

1. Position left side roof beam (23) against roof and install washers (32), lockwashers (31), and bolts (30).

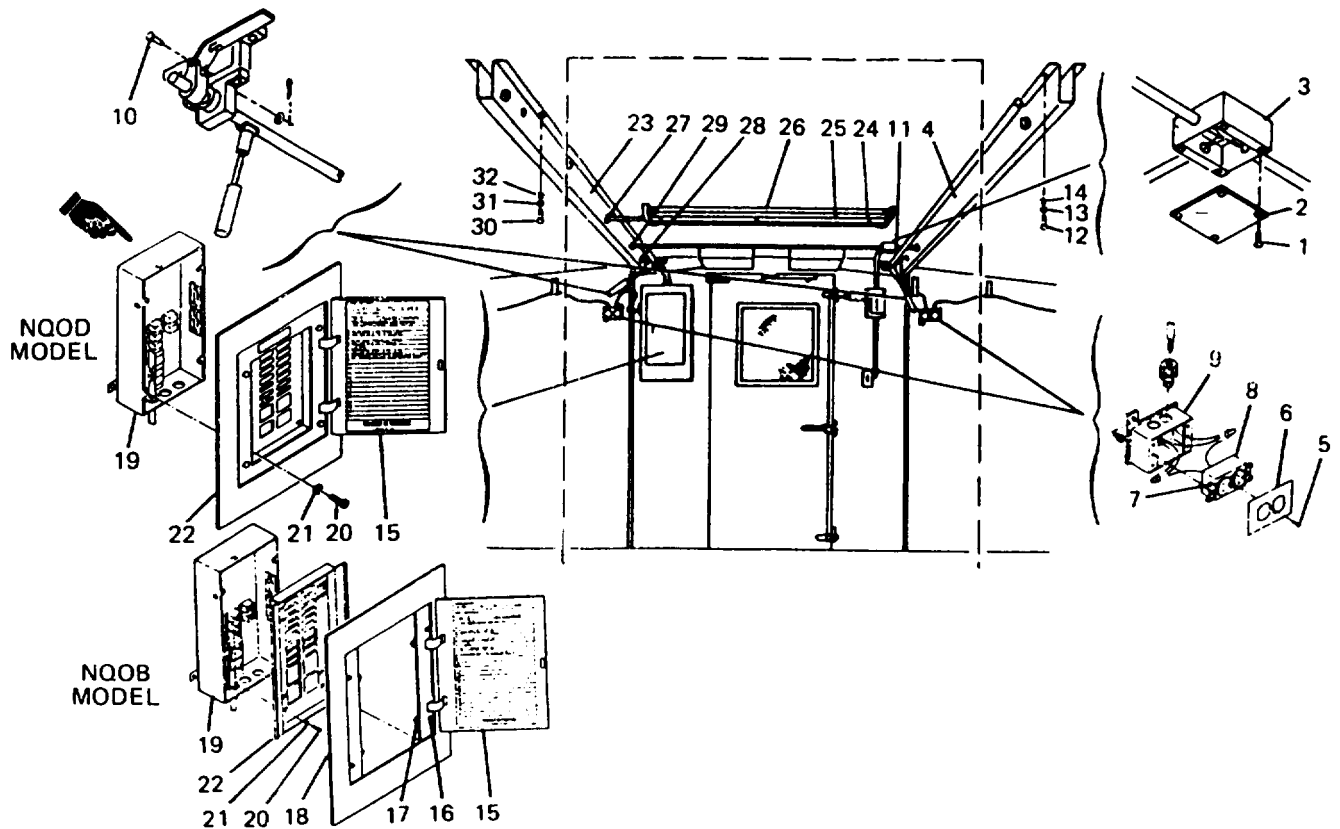

4-16. (cont)

2. Install push bar assembly pins (10) at each of three push bar assemblies.
3. Connect conduit locknut (29) at roof beam area between left side roof beam (23) and junction box (3).
4. Connect conduit locknut (28) at roof beam area between left side roof beam (23) and top of circuit breaker box (19).
5. Connect conduit locknuts (27) at roof beam area between left side roof beam (23) and each of three fixed roof area ceiling lights (26).
6. Connect wires from left side roof beam (23) to rear of receptacle (8).
(Refer to paragraph 4-46)
7. Install receptacle (8) in outlet box (9) and tighten two captive screws (7).
8. Attach duplex receptacle cover (6) to outlet box (9) with screw (5).

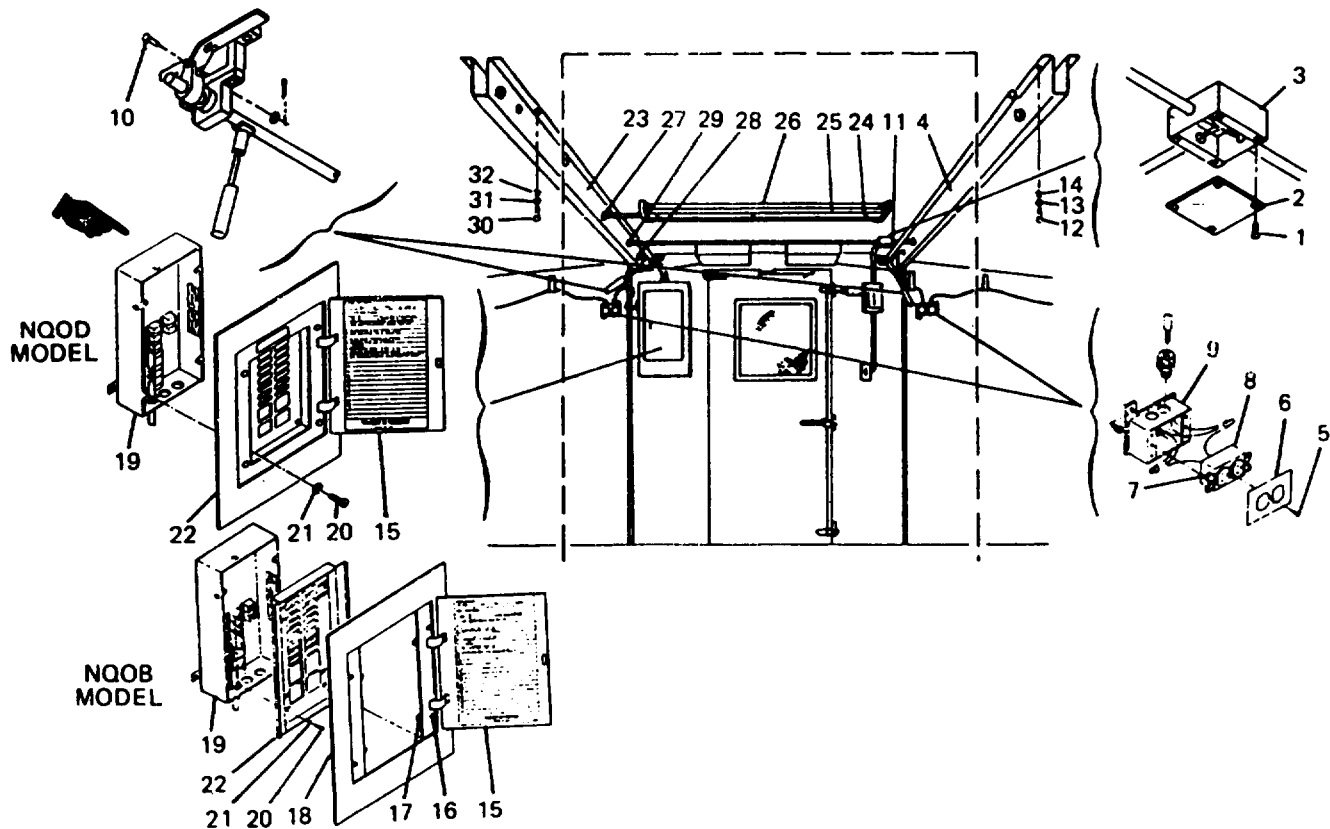

4-16. (cont)

9. Connect wires from left side roof beam (23) to each of three fixed roof area ceiling lights (26). (Refer to paragraph 4-46.)
10. Attach three fixed roof area ceiling light covers (25) to three fixed area ceiling lights (26) with nine screws (24).
11. Connect wires from left side roof beam (23) to junction box (3). (Refer to paragraph 4-46)
12. Attach junction box cover (2) to junction box (3) by installing four screws (1).
13. Connect wires from left side roof beam (23) to circuit breaker box (19). (Refer to paragraph 4-46)
14. On both models, position panel board (22) over circuit breakers in circuit breaker box (19) and secure with four screws (20) and washers (21).
15. On model NQOB, install panel cover (18) on the circuit breaker panel board (22), move four clamp fingers (17) to the CLOSE position and tighten captive screws (16).
16. Close circuit breaker panel door (15).

Right Side Roof Beam Wiring

1. Position right side roof beam (4) against roof and install washers (14), lockwashers (13), and bolts (12).
2. Connect conduit locknuts (11) between junction box (3) and right side roof beam (4).
3. Install three push bar assembly pins (10).
4. Connect wires from right side roof beam (4) to rear of two receptacles (8). (Refer to paragraph 4-46)
5. Install two receptacles (8) in two outlet boxes (9) and secure with four screws (7).
6. Attach receptacle cover (6) to outlet box (9) with screw (5) at each end of right side roof beam (4).
7. Connect wires from right side roof beam (4) to junction box (3). (Refer to paragraph 4-46)
8. Attach junction box cover (2) to junction box (3) by installing four screws (1).

4-17. PERSONNEL AND RIGHT CARGO DOOR REPLACEMENT, REPAIR, AND ALIGNMENT

This task covers:

- | | |
|-------------------------|-----------------|
| a. Removal | e. Assembly |
| b. Disassembly | f. Installation |
| c. Cleaning, Inspection | g. Alignment |
| d. Repair | |

INITIAL SETUP

Special tools

Hand blind riveter, Appendix B, Item 2

Personnel - 2

Materials

Sealing compound, Item 19,
Appendix E

Standard tools

General mechanics tool kit

REMOVAL

Personnel and Right Cargo Door

1. Remove hairpin (1), and pin (2), and swing back bracket (3).
2. Close door (4).
3. Remove four bolts (5), lockwashers (6), and washers (7) securing each of four hinge base plates (8) to endwall.

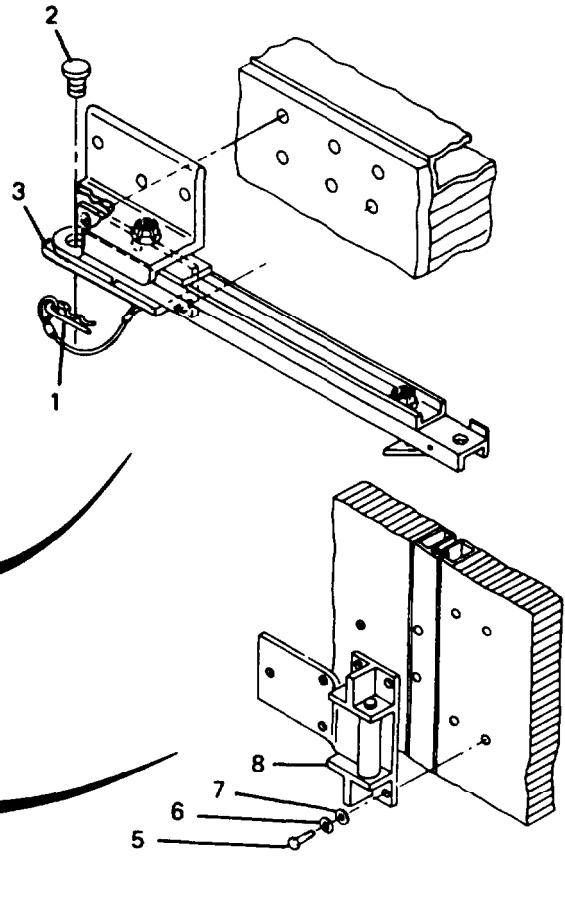

Door Vent

4. Drill out rivets (9) and remove four vent retainer strips (10). (Refer to paragraph 4-32)
5. Drill out rivets (11) and remove retainer strip (12) and rain strip (13). (Refer to paragraph 4-32)
6. Drill out rivets (14) and remove door vent (15). (Refer to paragraph 4-32)

4-17. (cont)

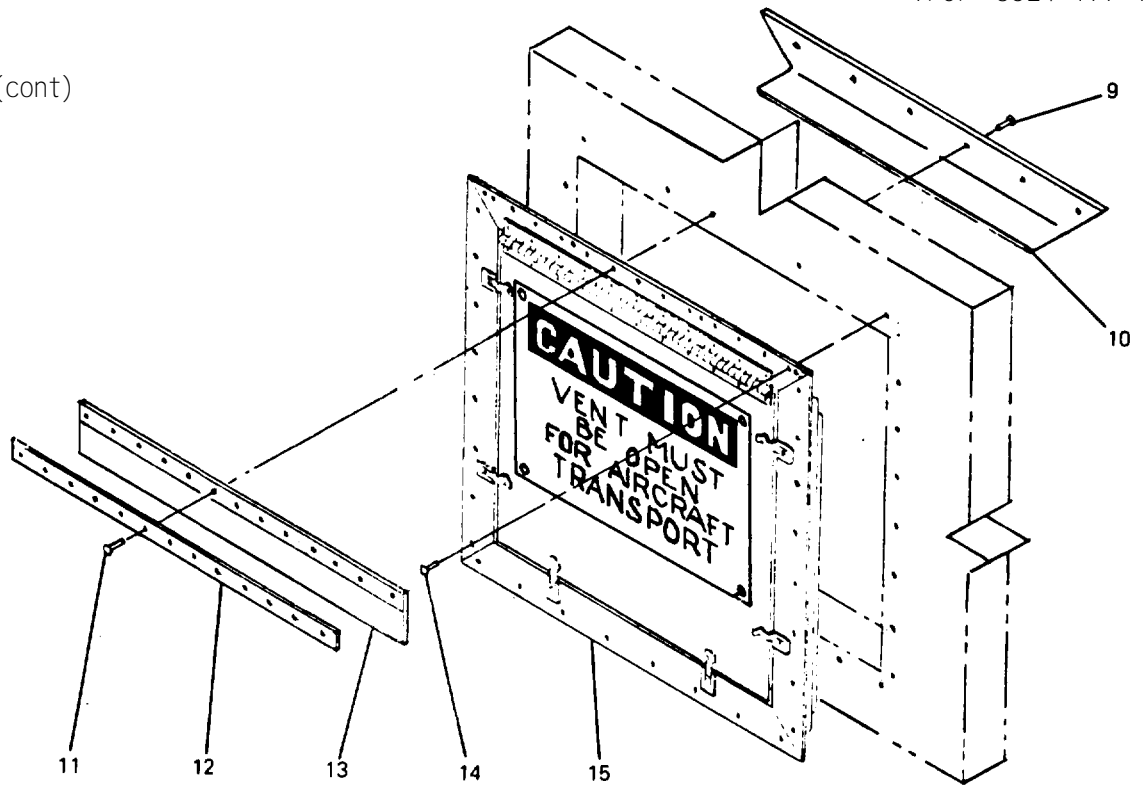

Door Lock Assembly

7. Remove three retaining rings (16), four flanged bearings (17), and top rod (18).
8. Remove four screws (32), four bolts (33), lockwashers (34), washers (35), mounting plates (36 and 37), and screw (38).

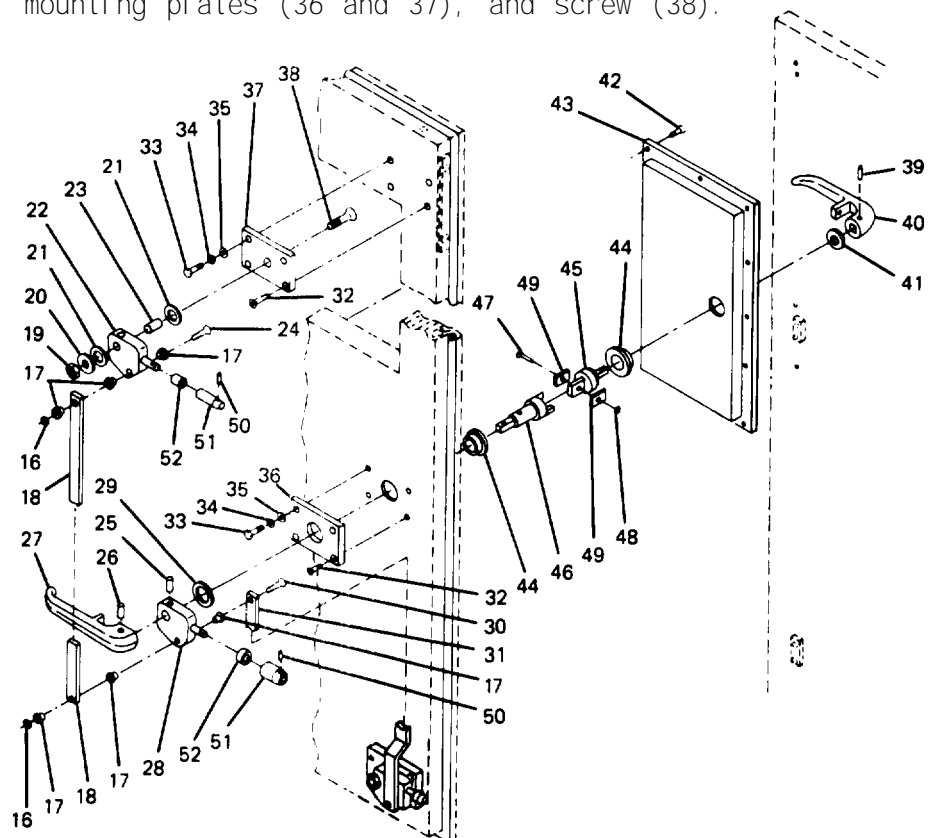

4-1.7. (cont)

9. Remove nuts (19), washers (20 and 21), latch arms (22), spacers (23), and pins (24).
10. Drive out dowel pins (25 and 26) and remove inside handle (27), latch arm (28), washer (29), pin (30) and bottom rod (31).
11. Repeat steps 7 through 10 to remove lower latch arm.
12. Drive out dowel pin (39) and remove outside handle (40) and washers (41).
13. Drill out rivets (42) and remove pan (43). (Refer to paragraph 4-32)
14. Remove flanged bearings (44) and shafts (45 and 46).
15. Drill out rivet (47) and remove washer (48) and spacers (49).
16. Drive out dowel pins (50) and remove rollers (51) and roller extensions (52).

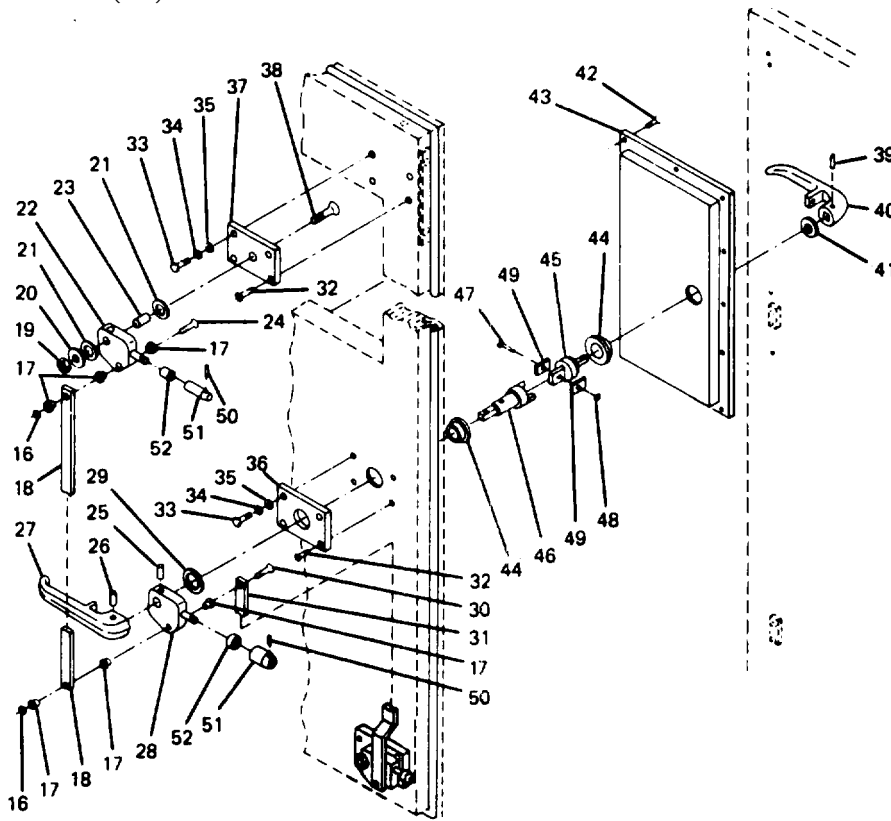

Door Stop Assembly

17. Remove six bolts (53 and 54), lockwashers (55), and washers (56).
18. Remove door stop assembly (57) from door.

4-17. (cont)

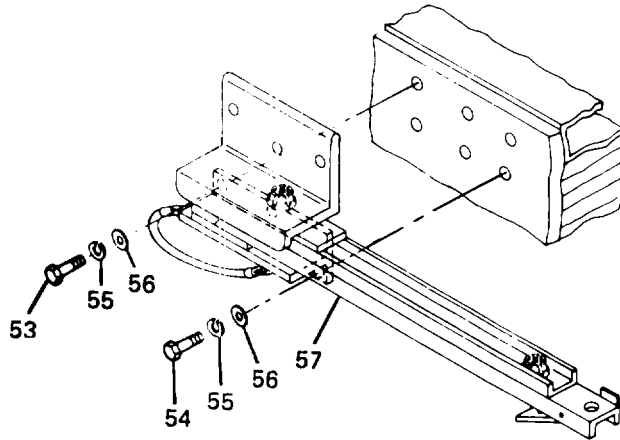

DISASSEMBLY

Personnel and Right Cargo Door

RIGHT CARGO DOOR PERSONNEL DOOR

NOTE
Letters locate detail
views described in
following procedures.

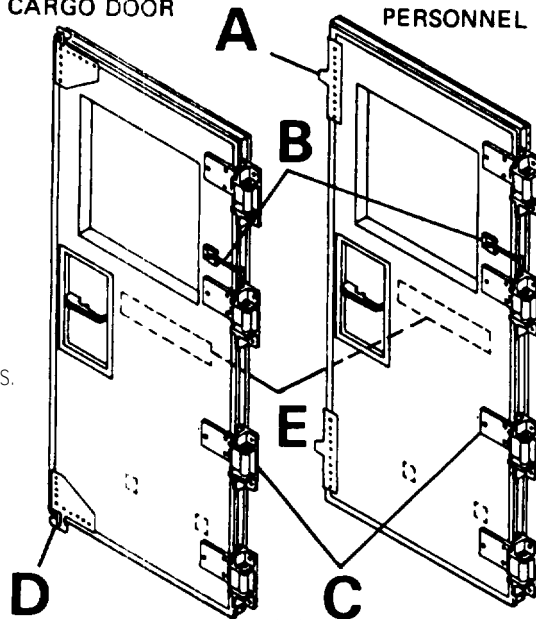

1. Remove screws (1) and lockwashers (2) securing personnel door shear plate (3) or cargo door shear plate (4) to door.

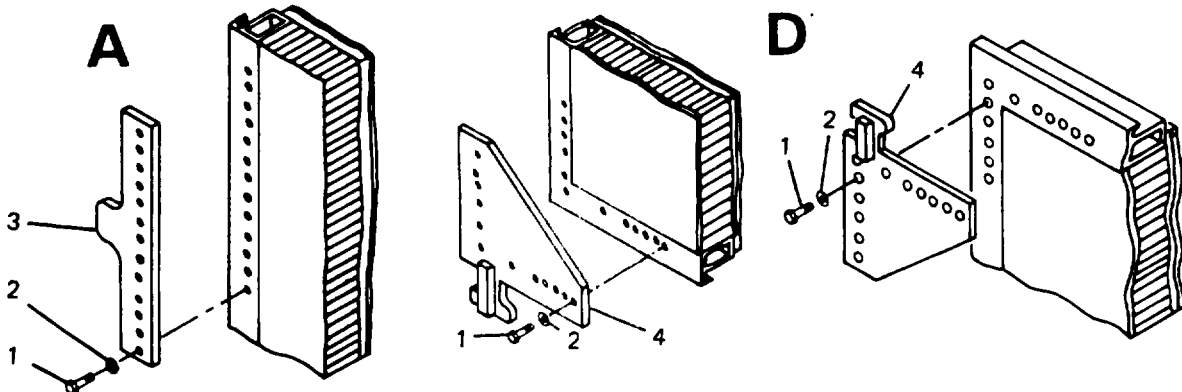

4-17. (cont)

2. Remove screws (5), lockwashers (6), and washers (7) securing door holder (8) to door.
3. Remove bolts (9), lockwashers (10), and washers (11) securing hinge (12) to door.
4. Remove screws (13) and lockwashers (14) securing jack storage bracket (15) to door.
5. Remove screws (16) securing jack support bracket (17) and spacer (18) to door.

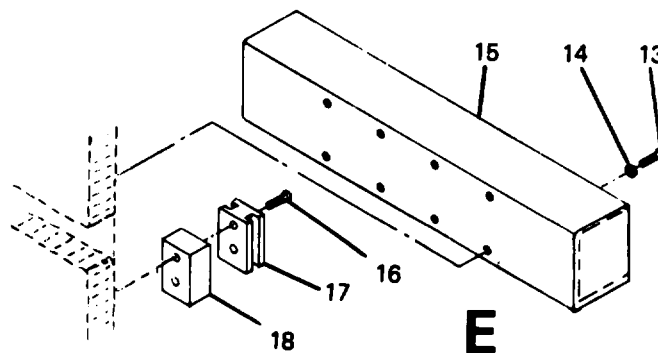
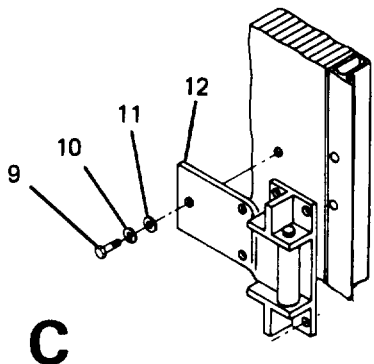
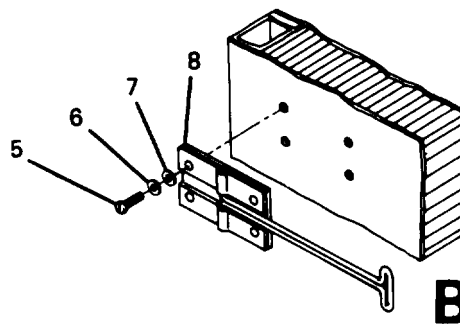

Door Vent

6. Remove screws (19), lockwashers (20), and washers (21) securing filter frame (22) and filter (23) to vent frame (24).
7. Drill out rivet (25) and remove fastener (26). (Refer to paragraph 4-32)
8. Drill out rivets (27) and remove hinge (28). (Refer to paragraph 4-32)

4-17. (cont)

9. Drill out rivets (29) and remove door vent (30), retainer strips (31), and curtain (32). (Refer to paragraph 4-32)
10. Remove bolts (33), washers (34), and spring (35).
11. Drill out rivets (36) and remove caution plate (37).

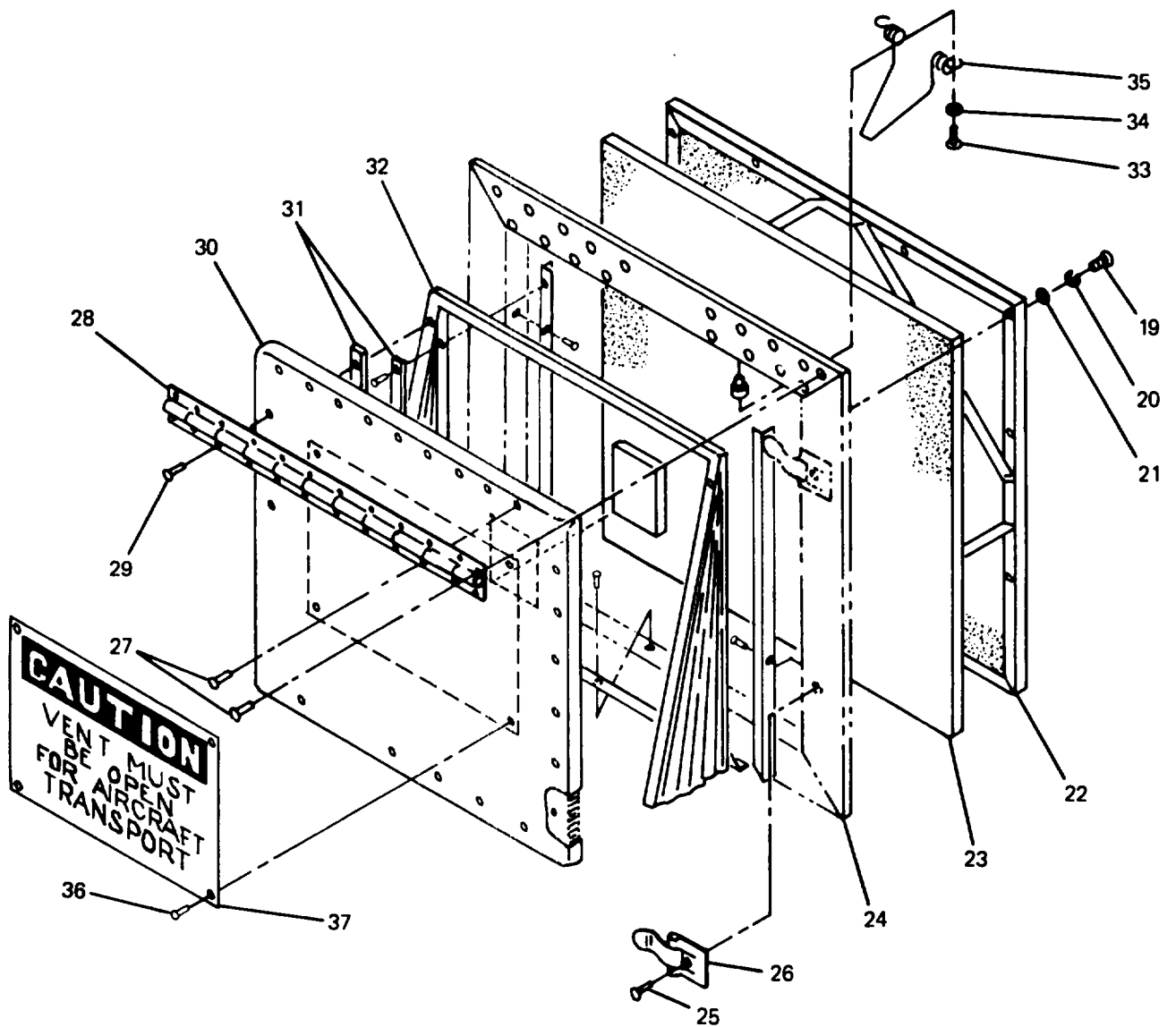

4-17. (cont)

Door Stop Assembly

12. Remove hair pin (38), pin (39), and bracket (40).
13. Drill out rivet (41) to remove lanyard (42). (Refer to paragraph 4-32)
14. Remove cotter pin (43), nut (44), washers (45), and bolt (46) securing bracket (47) to upper brace (48).
15. Remove cotter pin (49), nut (50), washers (51), nylon washer (52), and bolt (53) securing upper brace (48) to lower brace (54).
16. Compress spring (55) with catch (56) and drive out roll pin (57).

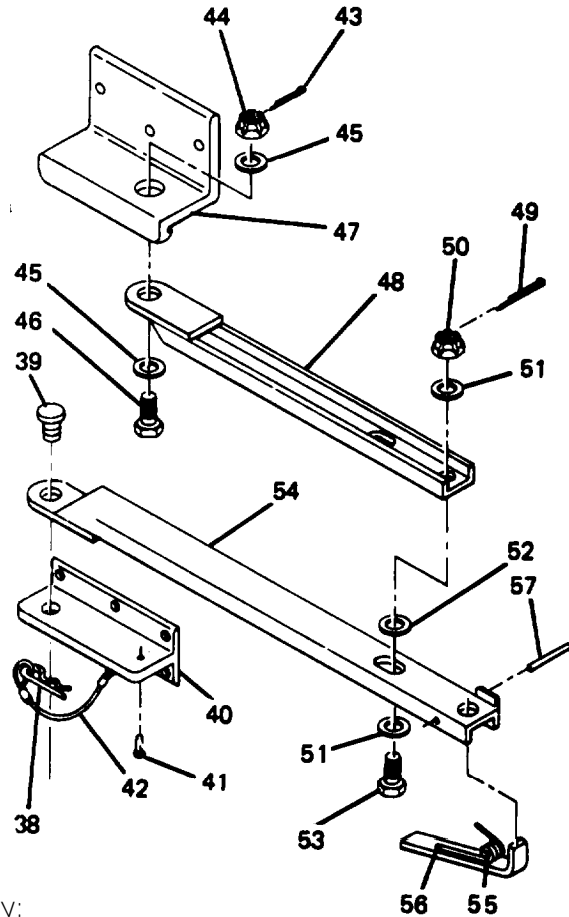

CLEANING, INSPECTION

1. Clean panel and component surfaces.
2. Inspect mounting surfaces for corrosion and damage.
3. Inspect for and replace if necessary:
 - a. Missing or damaged components
 - b. Corrosion or paint damage.

REPAIR

1. Panel skin damage. (Refer to paragraph 4-31 through 4-42)
2. Corrosion or paint damage. (Refer to paragraph 4-43)

ASSEMBLY

Door Stop Assembly

1. Position catch (56) and spring (55) in lower brace (54) and install roll pin (57).
2. Install bolt (53), washers (51), nylon washer (52), nut (50), and cotter pin (49) securing lower brace (54) to upper brace (48).
3. Install bolt (46), washers (45), nut (44), and cotter pin (43), securing upper brace (48) to bracket (47).

4-17. (cont)

4. Position lanyard (42) on bracket (40) and install rivet (41).
(Refer to paragraph 4-32)
5. Insert pin (39) through lower brace (54) and bracket (40) and install hair pin (38).
6. Refinish (paragraph 4-43)

Door Vent

7. Position spring (35) and install washers (34) and bolts (33).
8. Assemble curtain (32), retainer strips (31), and door vent (30) and install rivets (29).
9. Position hinge (28) and install rivets (27).
10. Position fastener (26) and install rivet (25).
11. Assemble vent frame (24), filter (23), and filter frame (22) and install washers (21), lockwashers (20), and screws (19).
12. Apply sealing compound to rear of caution plate (37), place against door vent (30) and install rivets (36).

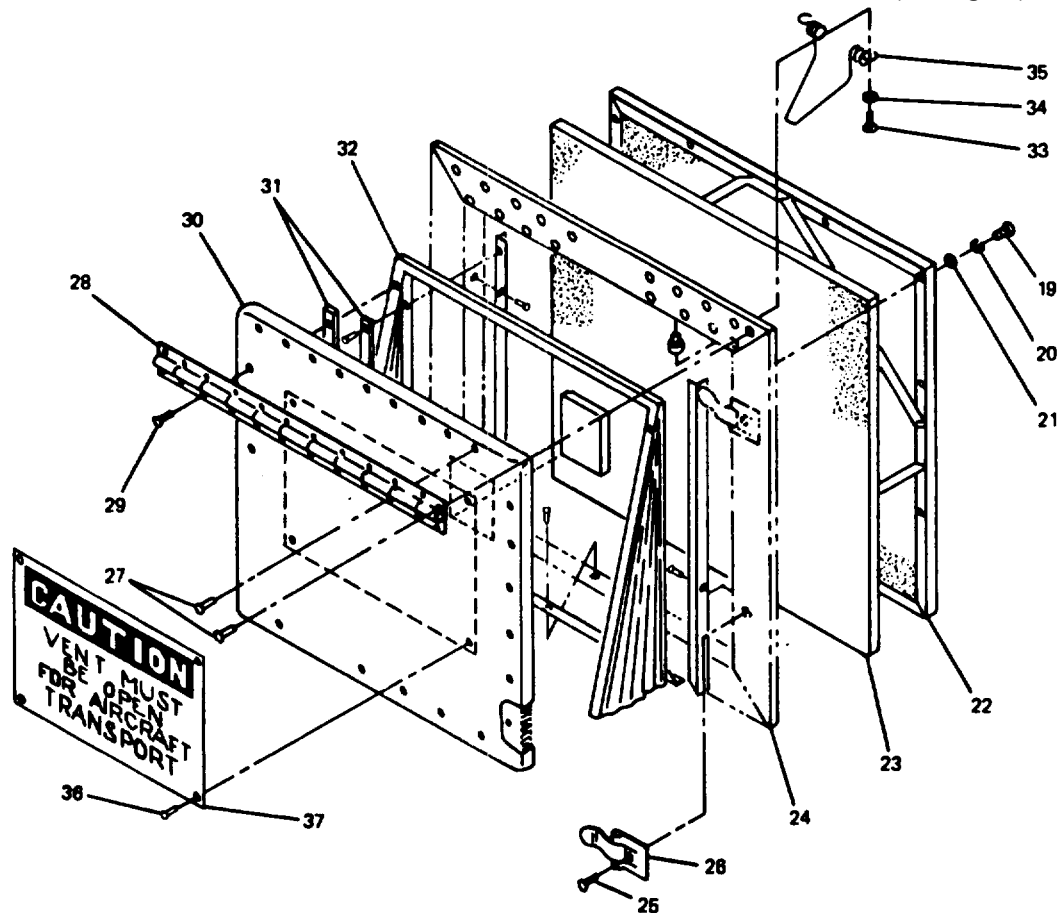

4-17. (cont)

Personnel and Right Cargo Door

13. Position spacer (18) and jack support bracket (17) on door and install screws (16).
14. Position jack storage bracket (15) on door and install lockwashers (14) and screws (13).

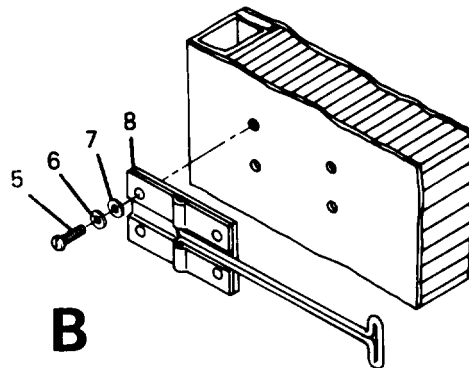
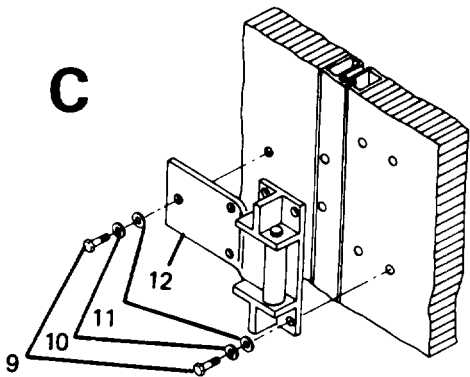
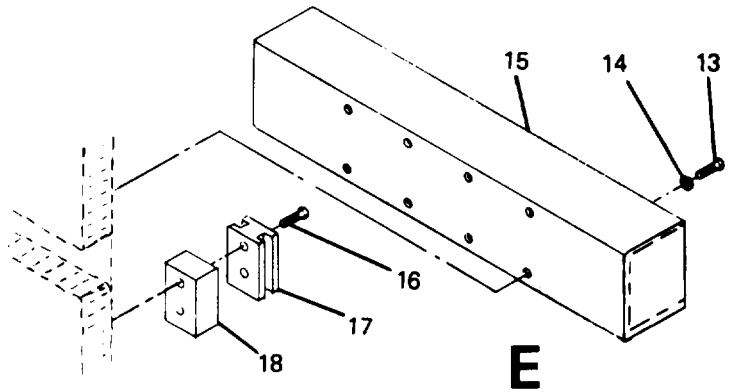

15. Position hinge base plate (12) on door and install washers (11), lock washers (10) and bolts (9).
16. Position door holder (8) on door and install washers (7), lockwashers (6), and screws (5).

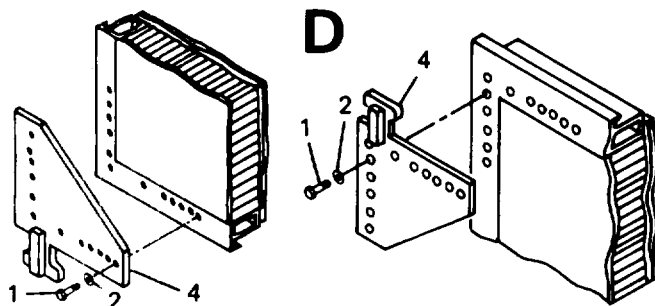
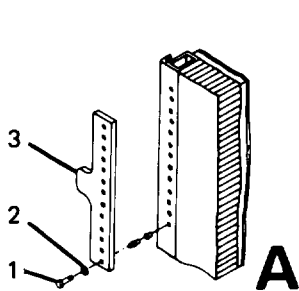

17. Position personnel shear plate (3) or cargo shear plate (4) on door and install lockwashers (2) and screws (1).
18. Seal (paragraph 4-42)
19. Refinish (paragraph 4-43)

4-17. (cont)

INSTALLATION

Door Stop Assembly

1. Attach door stop (57) to door with six washers (56), lockwashers (55), and bolts (53 and 54).

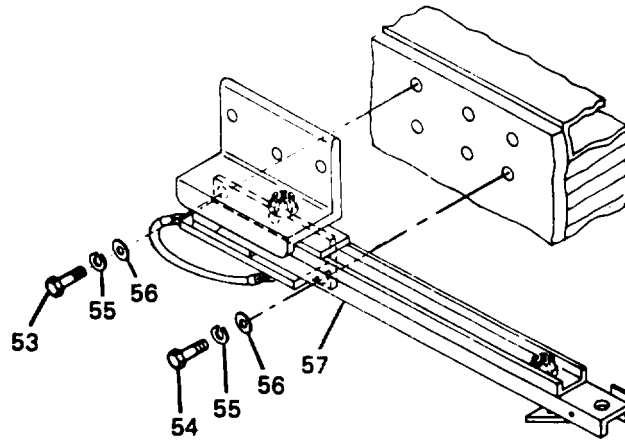

Door Lock Assembly

2. Install roller extensions (52), rollers (51), and dowel pins (50).
3. Install spacers (49), washer (48), and rivet (47). (Refer to para. 4-42)

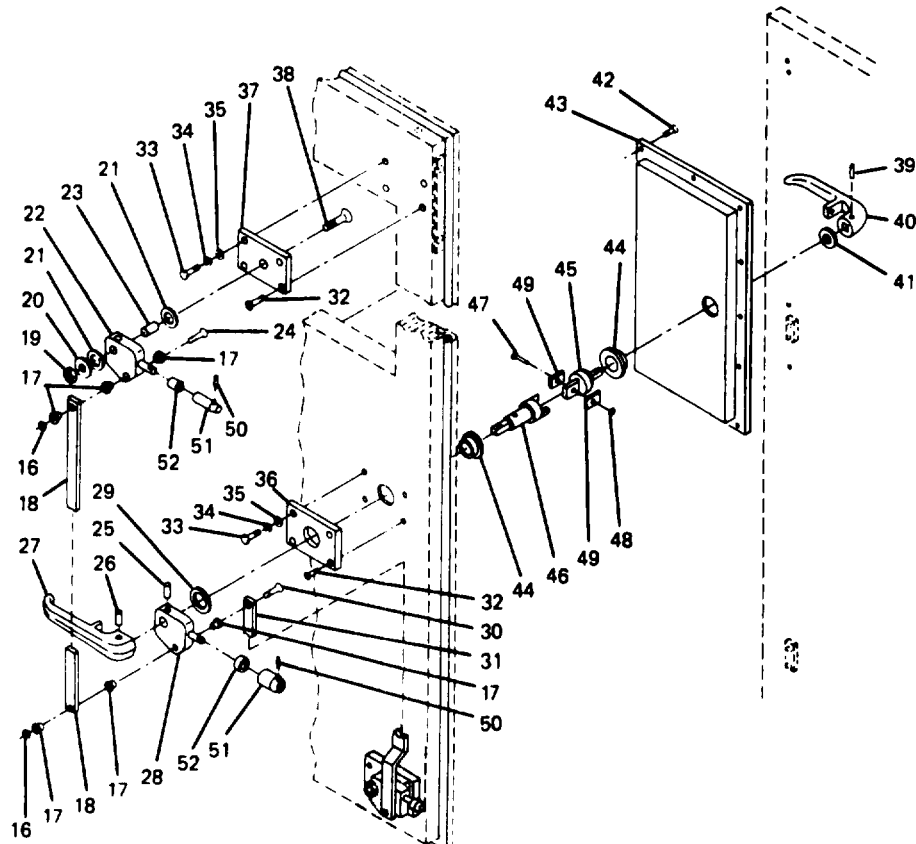

4-17. (cont)

4. Install shafts (46 and 45) and flanged bearings (44) in door panel.
5. Position pan (43) and install rivets (42). (Refer to paragraph 4-32)
6. Position washer (41) and outside handle (40) and install dowel pin (39).
7. Insert screw (38) in mounting plate (37) and install washers (35), lockwashers (34), bolts (33), and screws (32).
8. Position mounting plate (36) and install washers (35), lockwashers (34), bolts (33), and screws (32).
9. Position bottom rod (31), pin (30), flanged bearing (17), washer (29), latch arm (28), and inside handle (27) and install dowel pins (25 and 26).
10. Position flanged bearing (17), pin (24), washer (21), spacer (23), and latch arm (22) and install washers (20 and 21) and nut (19).
11. Position flanged bearing (17), top rod (18), and flanged bearing (17) and install retaining ring (16).
12. Seal (paragraph 4-42)
13. Refi ni sh (paragraph 4-43).

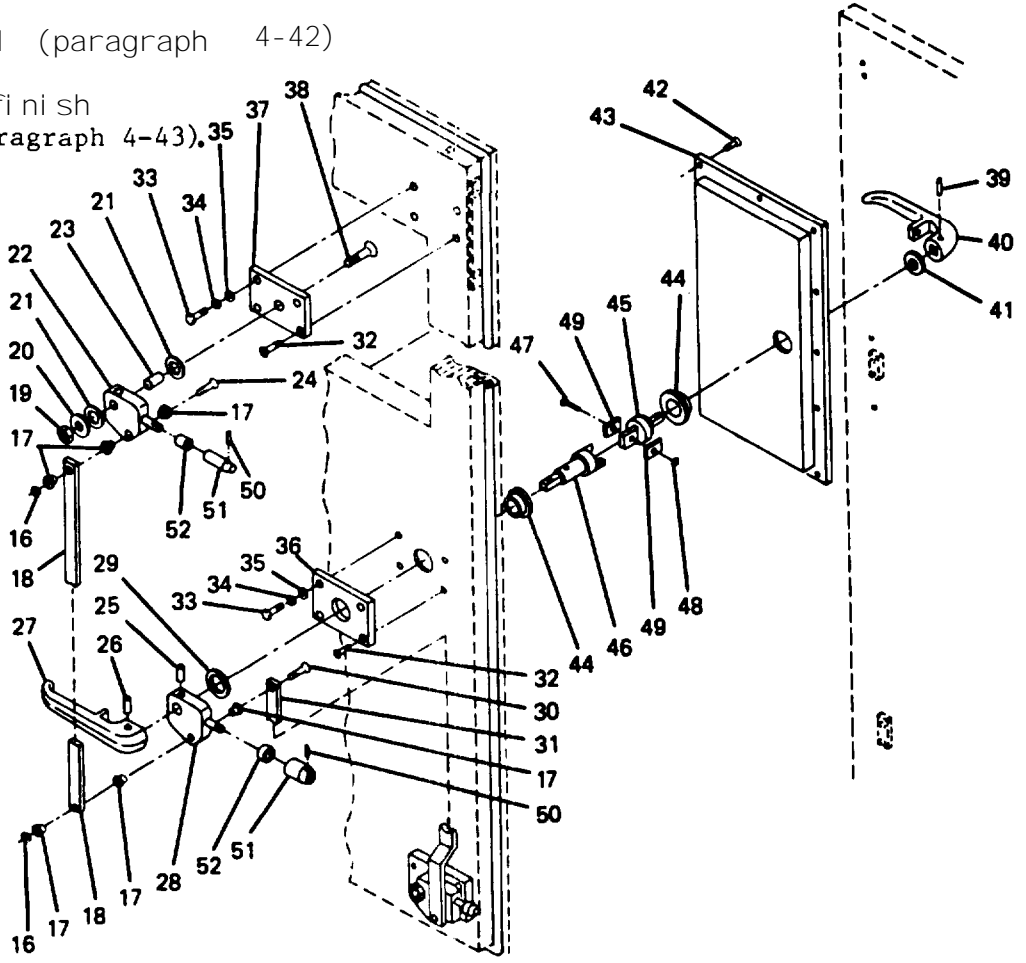

4-17. (cont)

Door Vent

14. Position vent (15) in door and install rivets (14). (Refer to paragraph 4-32)
15. Position rain strip (13) and retainer strip (12) and install rivets (11). (Refer to paragraph 4-32)
16. Position retainer strips (10) and install rivets (9). (Refer to 4-32.)

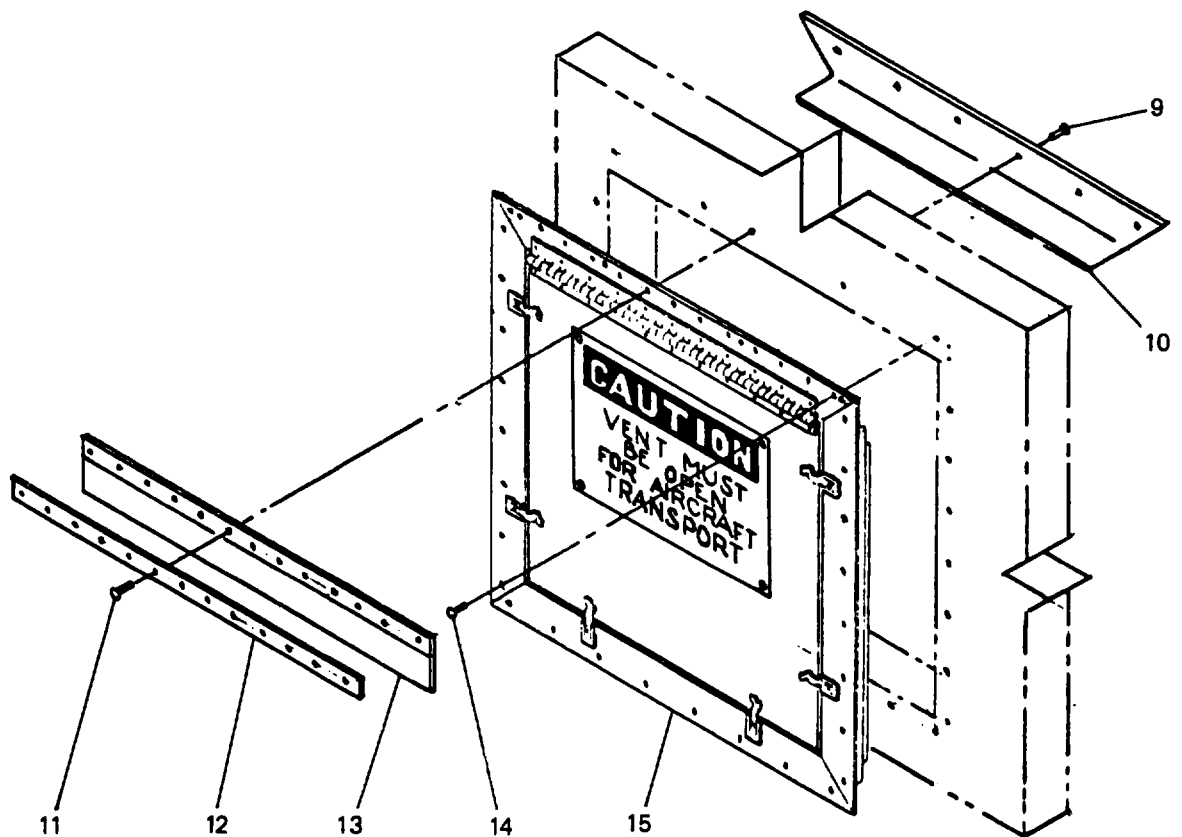

4-17. (cont)

Personnel and Right Cargo Door

- 17. Secure each of four hinge base plates (8) to endwall with four washers (7), lockwashers (6), and bolts (5).
- 18. Position bracket (3) and install pin (2) and hairpin (1).

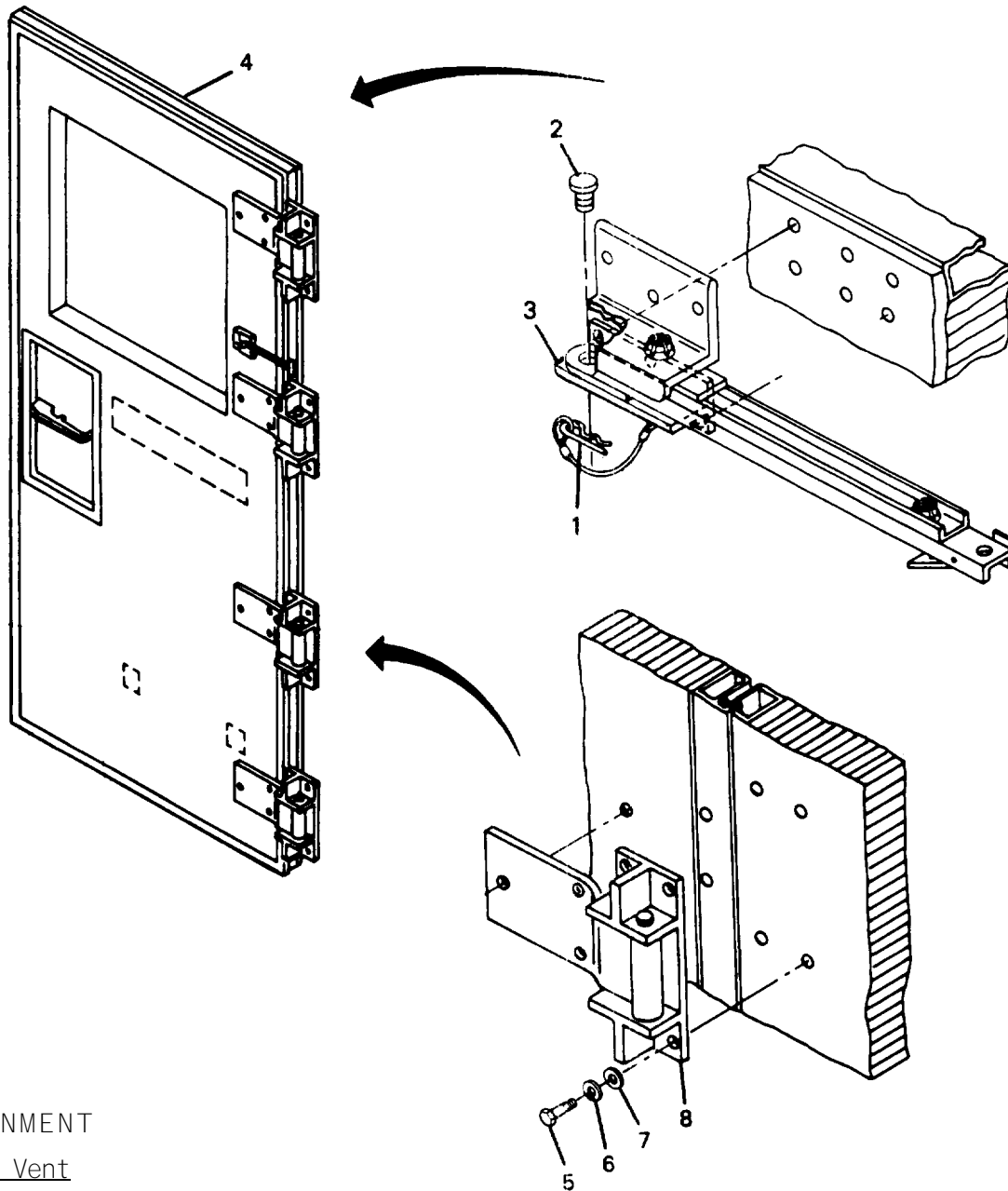

ALIGNMENT

Door Vent

When installing door vent, make sure to center in door so there is an equal gap at both sides and at the top and bottom.

4-17. (cont)

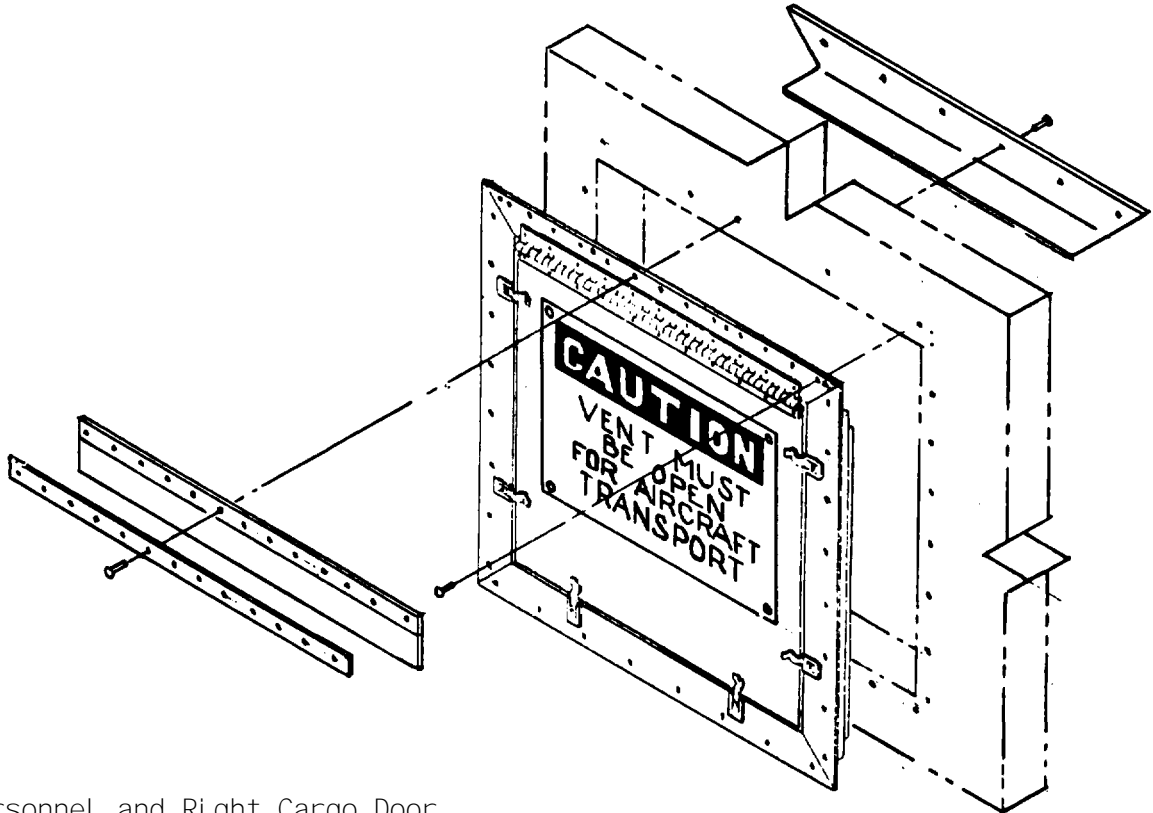

Personnel and Right Cargo Door

Loosen hinge bolts and place wedges as required around periphery of door so there is an equal gap at both sides and at top and bottom.

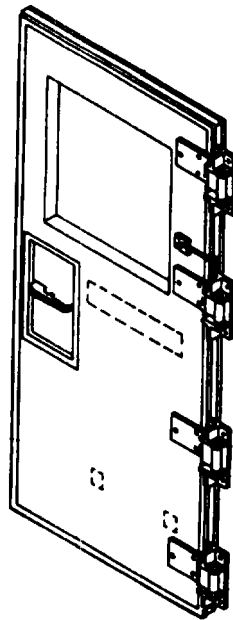

4-18. LEFT CARGO DOOR REPLACEMENT, REPAIR, AND ALIGNMENT

This task covers:

- | | |
|-------------------------|-----------------|
| a. Removal | e. Assembly |
| b. Disassembly | f. Installation |
| c. Cleaning, Inspection | g. Alignment |
| d. Repair | |

INITIAL SETUP

Standard Tools

General mechanics tool kit

Personnel - 2

REMOVAL

Left Cargo Door

1. Remove three bolts (1), lockwashers (2), and washers (3) securing door stop (4) to endwall.
2. Close door.
3. Remove four bolts (5), lockwashers (6), and washers (7) securing each of four hinge base plates (8) to endwall.

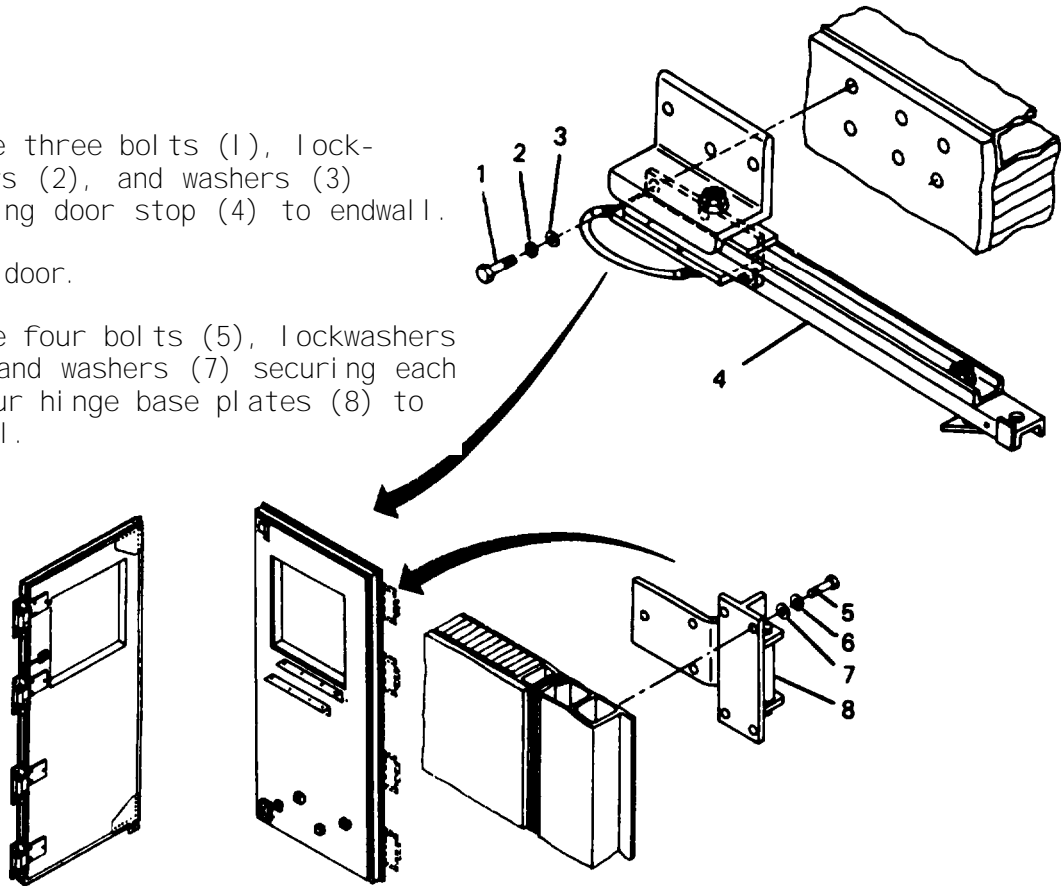

Door Vent

Refer to paragraph 4-17.

Foot Bolt Assembly

4. Remove six screws (9 and 10), lockwashers (11), and washers (12), securing foot bolt assembly (13) and spacer (14) to door.

4-18. (cont)

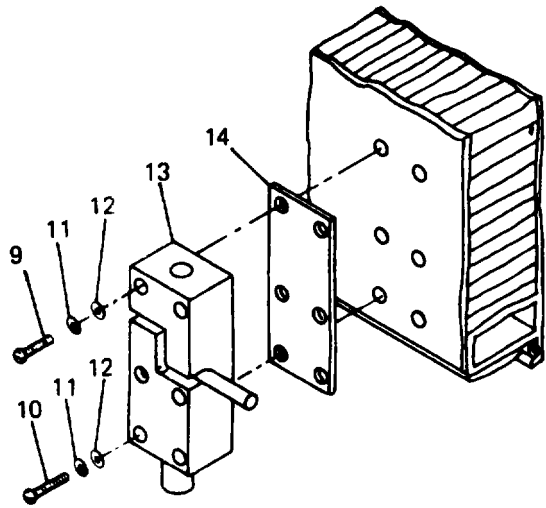

Chain Bolt Assembly

5. Remove six screws (15, 16, and 17), lockwashers (18), and washers (19) securing chain bolt housing (20), and chain bolt (21) to door.

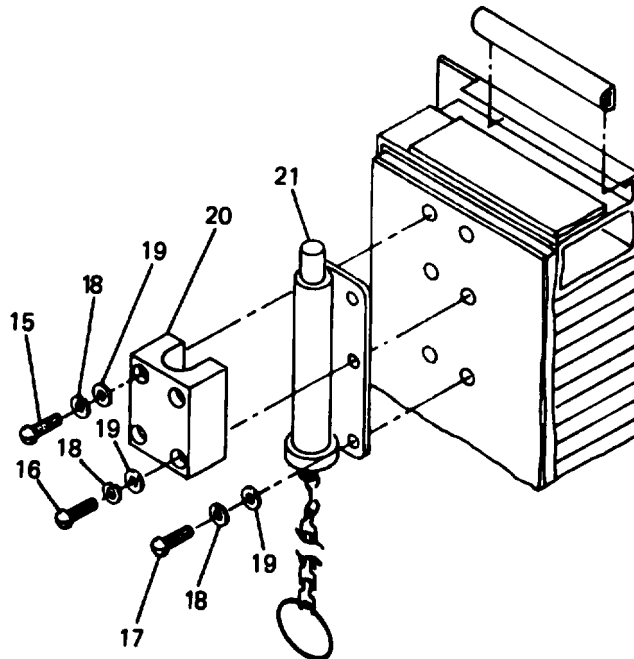

4-18. (cont)

DISASSEMBLY

Left Cargo Door

NOTE
Letters locate detail views described in following procedures.

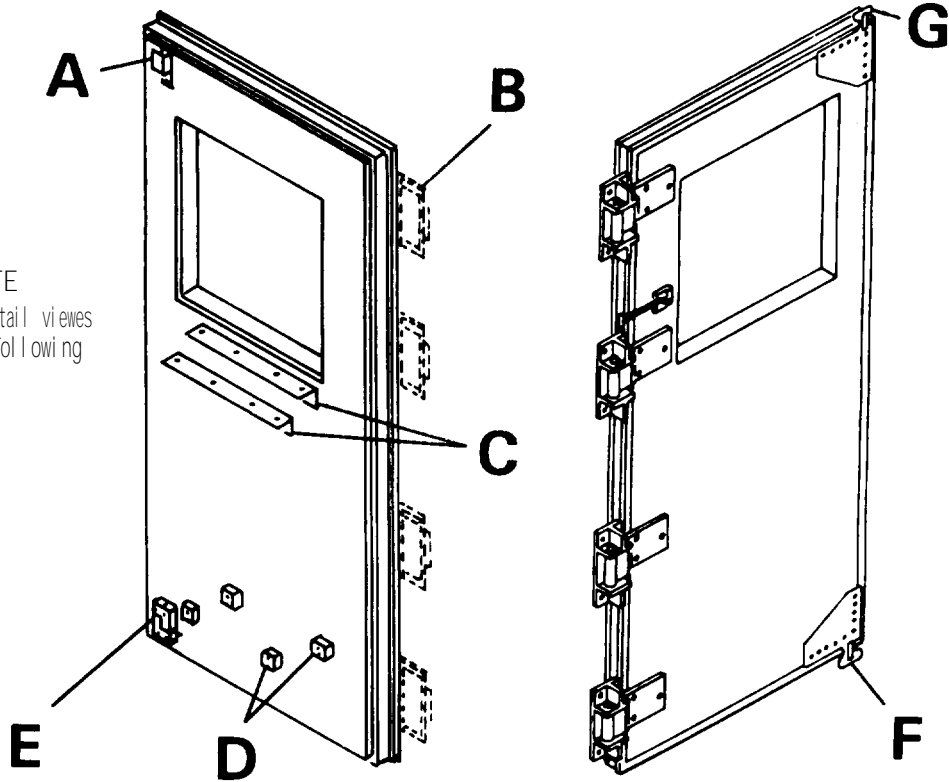

1. Remove six screws (1, 2, and 3), lockwashers (4), and washers (5) securing chain bolt housing (6) and chain bolt (7) to door.
2. Remove screws (8), lockwashers (9), and washers (10) securing door holder (11) to door.
3. Remove bolts (12), lockwashers (13), and washers (14) securing hinge plate (15) to door and panel.

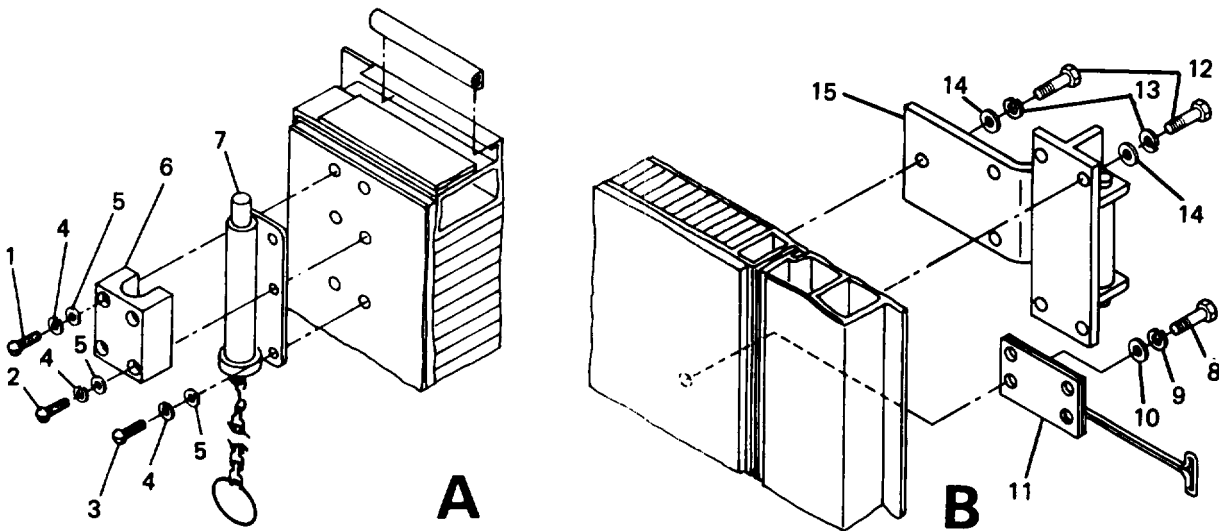

4-18. (cont)

4. Remove screws (16 and 17), lockwashers (18), and washers (19) securing foot bolt assembly (20) and spacer (21) to door.

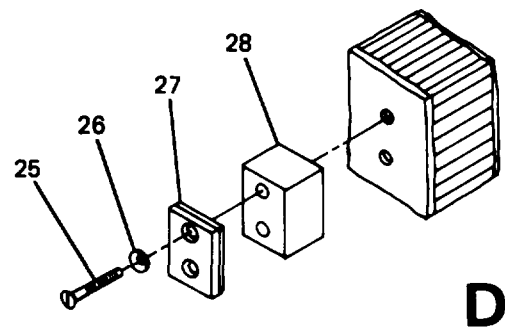
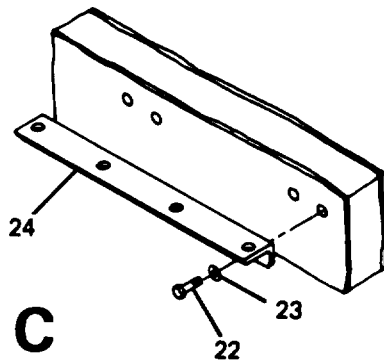
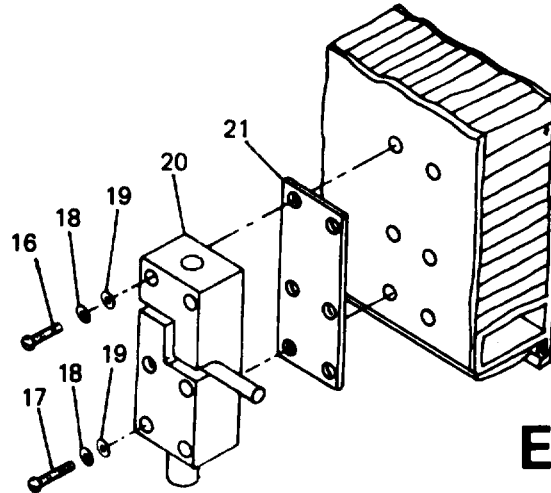

5. Remove screws (22) and lockwashers (23) securing jack stowage angle (24) to door.

6. Remove screws (25) and lockwashers (26) securing jack support bracket (27) and spacer (28) to door.

7. Remove screws (29) and lockwashers (30) securing shear plate (31) to door.

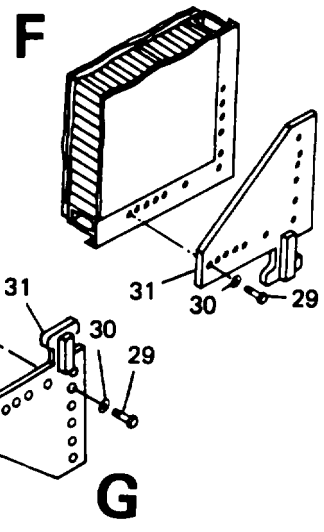

4-18. (cont)

Door Vent

Refer to paragraph 4-17.

Foot Bolt Assembly

8. Remove spring pin (32) from housing (35).
9. Remove shaft (34) and compression spring (33) from housing (35).

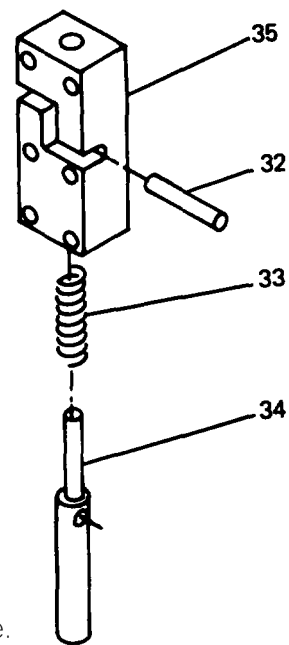

CLEANING, INSPECTION

1. Clean panel and component surfaces.
2. Inspect mounting surfaces for corrosion and damage.
3. Inspect for and replace if necessary:
 - a. Missing or damaged components
 - b. Corrosion or paint damage.

REPAIR

1. Panel skin damage. (Refer to paragraph 4-31 thru 4-42)
2. Corrosion or paint damage. (Refer to paragraph 4-43)

Foot Bolt Assembly

1. Install compression spring (33) and shaft (34) in housing (35).
2. Compress spring slightly until spring pin hole aligns with slot. Install spring pin (32) in housing (35).

Door Vent

Refer to paragraph 4-17.

Left Cargo Door

3. Position shear plate (31) on door and install lockwashers (30) and screws (29).

4-18. (cont)

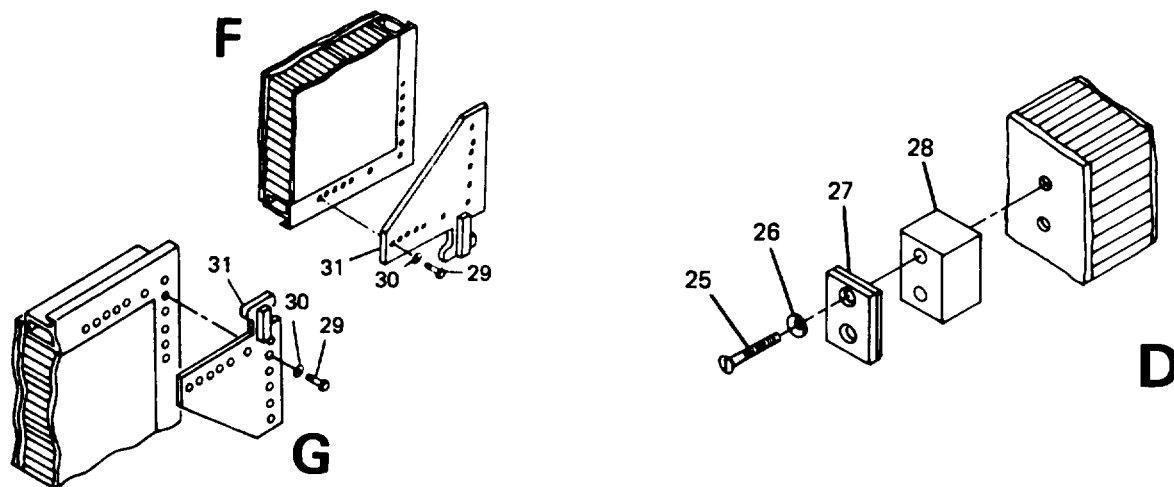

4. Position spacer (28) and jack support bracket (27) on door and install lockwashers (26) and screws (25).
5. Position jack storage angle (24) on door and install lockwashers (23) and screws (22).

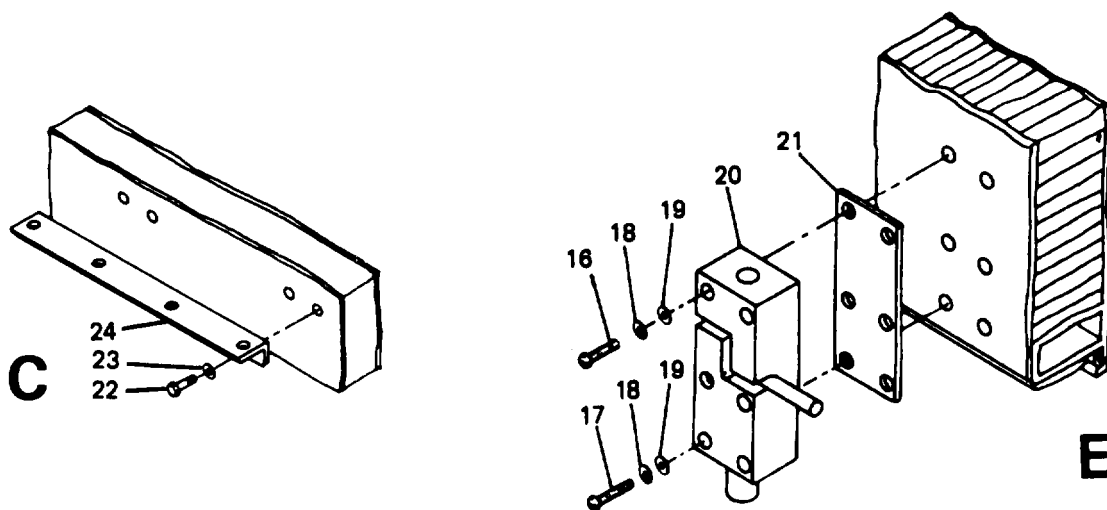

6. Position spacer (21) and foot bolt assembly (20) on door and install washers (19), lockwashers (18), and screws (16 and 17).
7. Position hinge plate (15) on door and install washers (14), lockwashers (13), and bolts (12).

4-18. (cont)

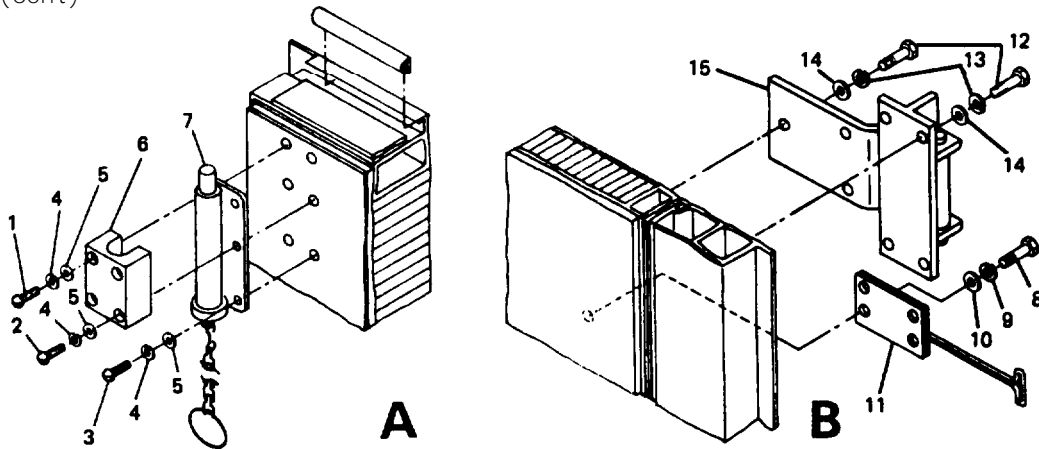

8. Position door holder (11) on door and install washers (10), lockwashers (9), and screws (8).
9. Position chain bolt (7) and chain bolt housing (6) on door and install washers (5), lockwashers (4), and screws (1, 2 and 3).
10. Seal (paragraph 4-42)
11. Refinish (paragraph 4-43)

INSTALLATION

Chain Bolt Assembly

1. Secure chain bolt (21) and chain bolt housing (20) to door with six washers (19), lockwashers (18), and screws (15, 16, 17).

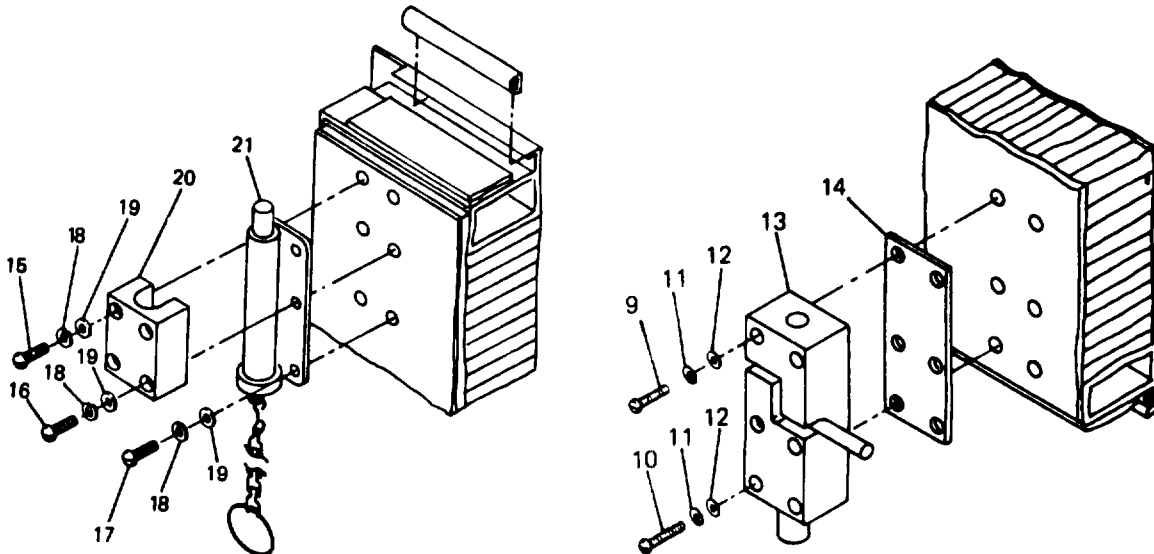

Foot Bolt Assembly

2. Secure spacer (14) and foot bolt assembly (13) to door with six washers (12), lockwashers (11), and screws (9 and 10).

4-18. (cont)

Left Cargo Door

3. Secure each of four hinge base plates (8) to endwall with four washers (7), lockwashers (6), and bolts (5).
4. Secure door stop (4) to endwall with three washers (3), lockwashers (2), and bolts (1).

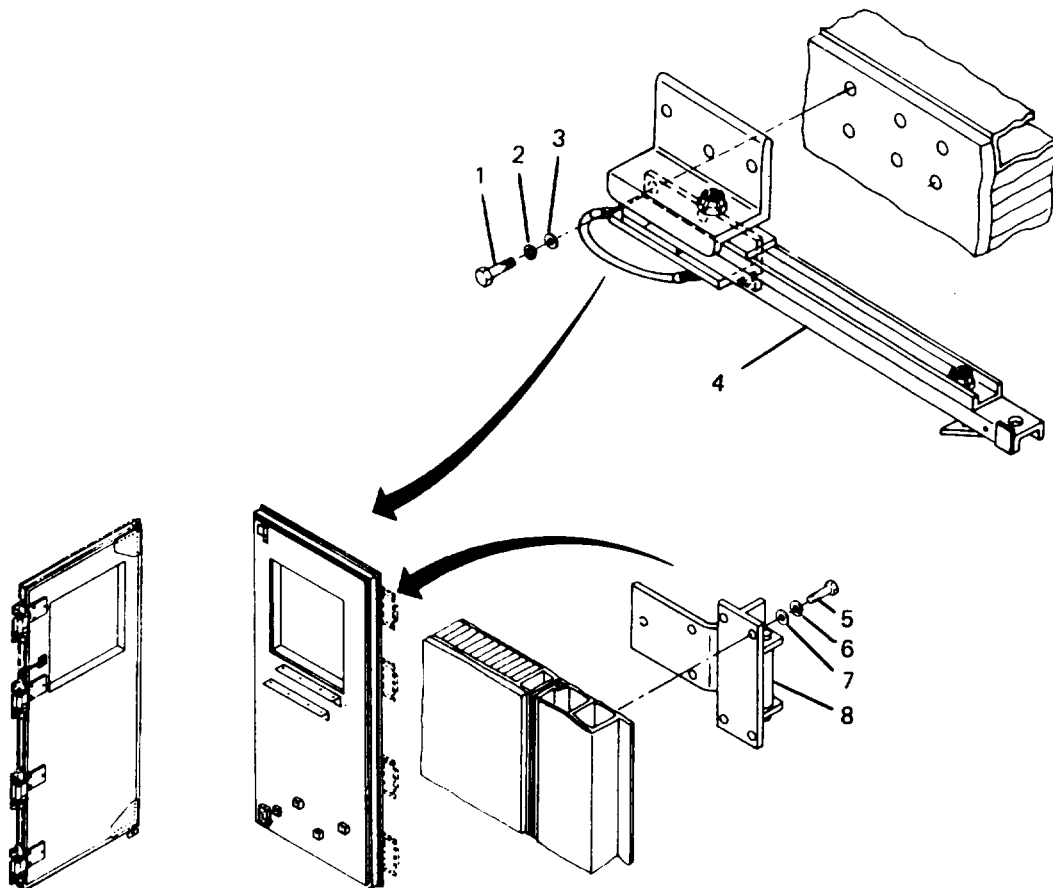

Foot Bolt Assembly

Add shims as necessary between foot bolt assembly and door to properly align foot bolt assembly.

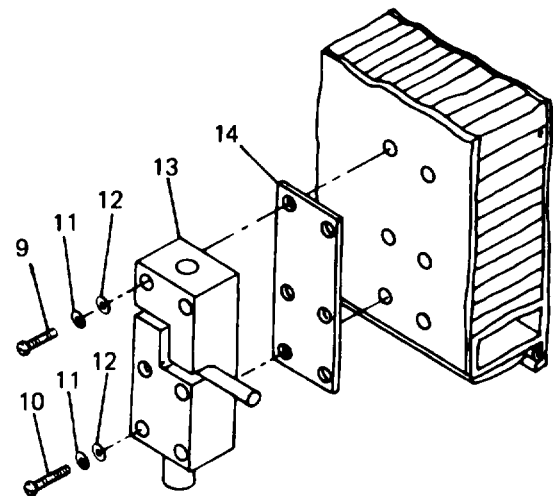

4-18. (cont)

Left Cargo Door

Loosen hinge bolts and place a wedge in the area of the door to take up any slack and align the door properly. Tighten hinge bolts.

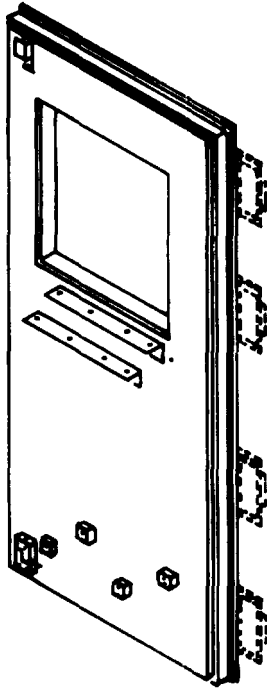

4-19. HINGED PANEL LEVELING JACK ASSEMBLY SERVICE AND REPAIR

This task covers:

- | | |
|-------------------------|----------------|
| a. Disassembly | d. Lubrication |
| b. Cleaning, Inspection | e. Assembly |
| c. Repair | |

INITIAL SETUP

Standard tools

General mechanics tool kit
Grease gun

Materials

Grease, Item 12, Appendix E

DI SASSEMBLY

Jack Assembly

1. Remove nut (1), spring plunger (2), and lower pin (3).
2. Remove upper pin (4) and separate handle (5) from support (6).

4-19. (cont)

3. Remove grease fitting (7).
4. Remove rivet (8) to remove lanyard (9) and safety pin (10).

NOTE

Do not remove lanyard unless pins or cables are damaged.

5. Remove screws (11) and spring tension clip (12).
6. Remove cotter pin (13), washer (14), pin (15), and spacers (16) to remove base (17) from basic jack.
7. Remove inside tube (18) and jack screw (19) from outside tube (20).
8. Remove bearing (21).
9. Drive pin (22) out through access hole and remove jack screw (19) from inside tube (18).
10. Remove O-rings (29) from handle (5).

Jack Extension

11. Remove quick-disconnect pins (23) and remove inside tube (24) from outside tube (25).
12. Remove screw (27), washer (28), and lanyard (26).

NOTE

Do not remove lanyards unless pins or cables are damaged.

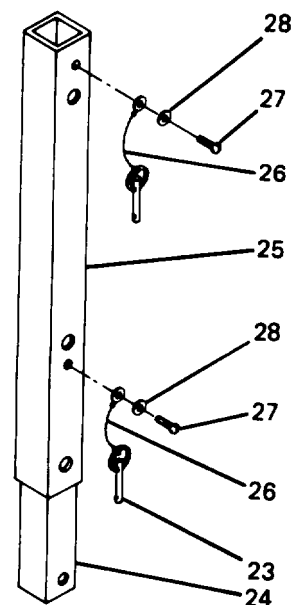
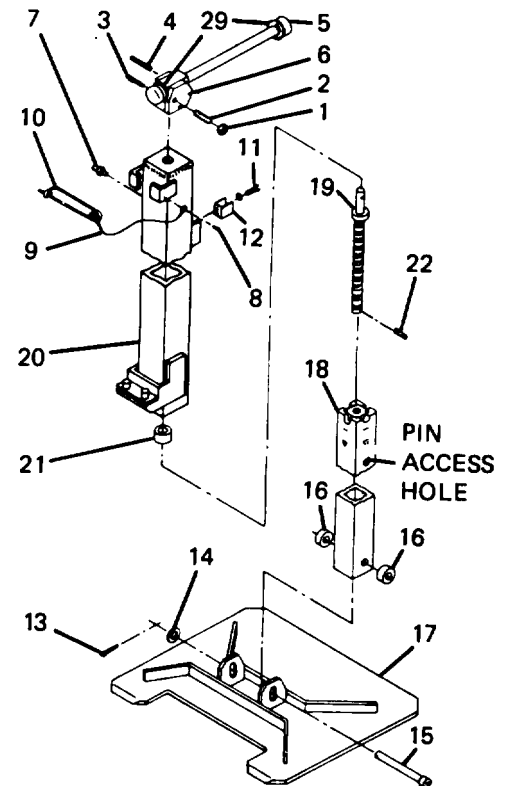

4-19. (cont)

CLEANING, INSPECTION

1. Clean jack assembly and component surfaces.
2. Inspect mounting surfaces for corrosion and damage.
3. Inspect for and replace if necessary:
 - a. Missing or damaged components
 - b. Corrosion or paint damage.

REPAIR

Corrosion or paint damage. (Refer to paragraph 4-43)

LUBRICATION

Lubricate jack assembly with grease.

ASSEMBLY

Jack Extension

1. Install lanyard (26), washer (28), and screw (27).
2. Install inside tube (24) in outside tube (25) and secure with quick-disconnect pins (23).

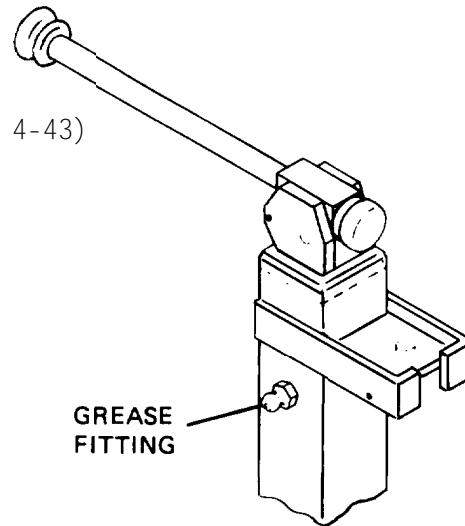

Jack Assembly

3. Install jack screw (19) in inside tube (18).
4. Align hole in jack screw (19) with access hole in inside tube (18) and install pin (22).
5. Pack bearing (21) with grease and place on jack screw (19).
6. Install inside tube (18) in outside tube (20).

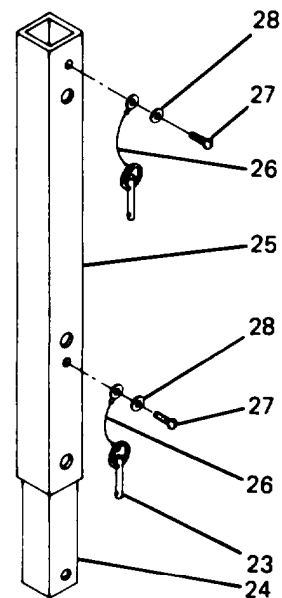

4-19. (cont)

7. Position spring tension clip (12) on outside tube (20) and install screws (11).
8. Assemble O-rings (29) on handle (5).
9. Position handle (5) in support (6) and on jack screw (19) with holes in handle yoke and jack screw aligned. Install pins (3 and 4).
10. Install spring plunger (2) in handle yoke and secure with nut (1). Adjust nut to control handle movement.
11. Position basic jack on base (17) with spacers (16) and secure with pin (15), washer (14), and new cotter pin (13).
12. Install grease fitting (7) and lubricate jack with grease.

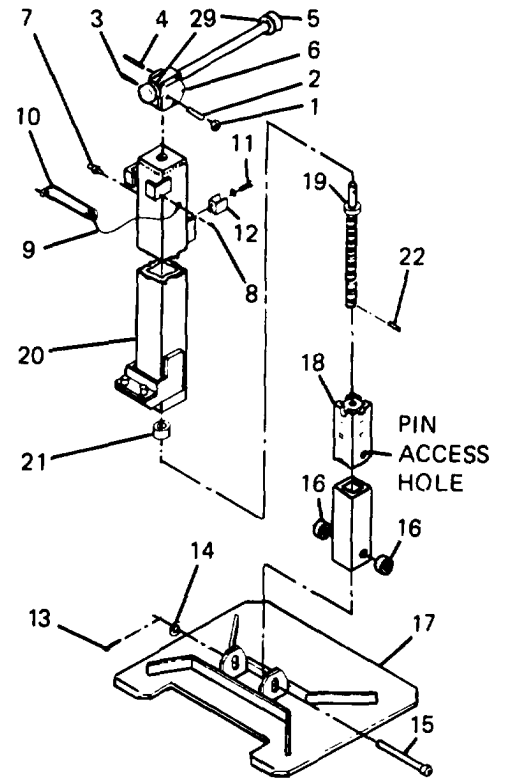

4-20. HINGED ROOF PANEL SERVICE, REPLACEMENT, REPAIR, AND ALIGNMENT

This task covers:

- | | |
|-------------------------|-----------------|
| a. Lubrication | e. Repair |
| b. Removal | f. Assembly |
| c. Disassembly | g. Installation |
| d. Cleaning, Inspection | h. Alignment |
-

INITIAL SETUP

Special Tools

Hand blind riveter, Appendix B, Item 2

Standard Tools

General mechanics tool kit

Personnel - 4

1 Electrician

Materials

Adhesive, Item 2, Appendix E
 Adhesive, Item 3, Appendix E
 Sealant, Item 18, Appendix E
 Silicone Grease, Item 23, Appendix E

Equipment Condition

Hinged endwalls removed, paragraph 4-21
 Hinged roof area ceiling lights removed, paragraph 3-5

4-20. (cont)

LUBRI CATION

Lubricate rollers on hinged roof panel with a coat of silicone grease annually.

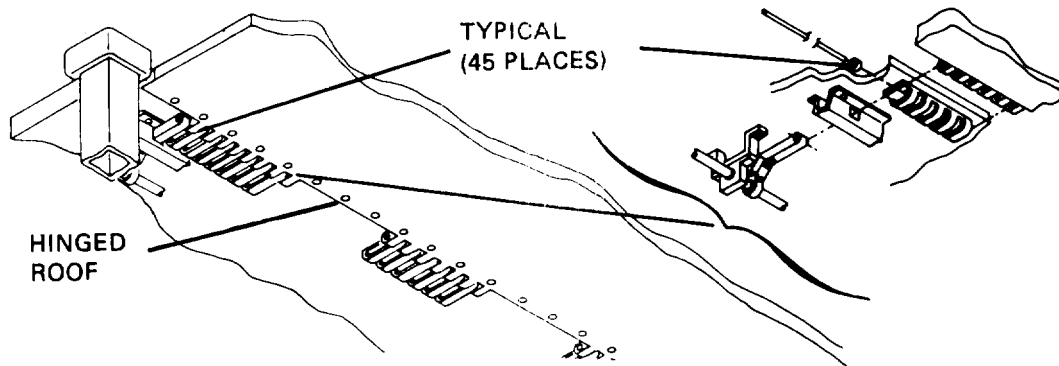

REMOVAL

Hinged Roof Panel

WARNI NG

The shelter contains voltages that are dangerous if contacted. Before removing or installing electrical cables or components, make certain electrical power is completely disconnected from circuit involved.

CAUTI ON

Support braces must be installed for this operation.

NOTE

Remove only those electrical components that will interfere with removal of a particular panel.

1. Set main circuit breaker to off position.
2. Lower hinged floor (1).
3. Raise hinged sidewalls (2) and install support braces (3).
4. Position leveling jacks (4).

4-20. (cont)

5. Support hinged roof (9) in stowed position, straighten ends of hinge pin first, and remove hinge pins (5, 6, and 7) and rollers (8).
6. Remove hinged roof (9).

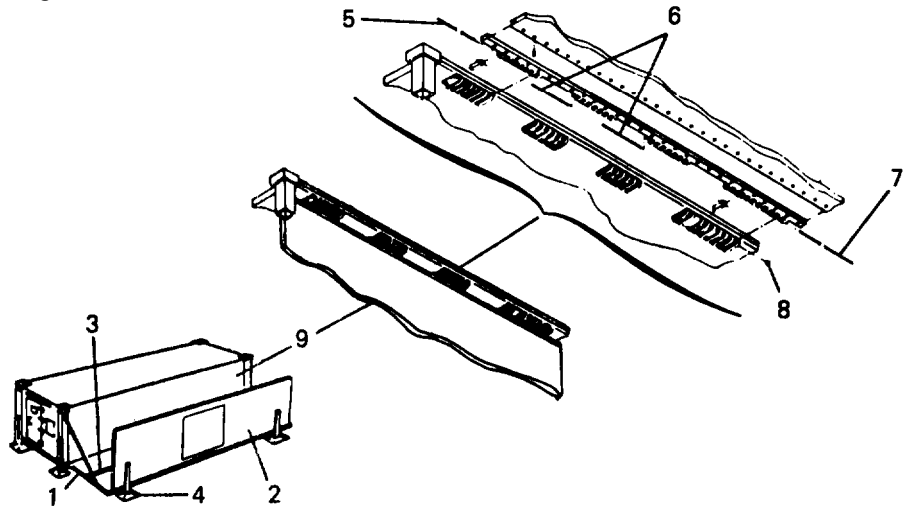

Support Strut Assembly

7. Remove pin (11) and lower support strut assembly to vertical position.
8. Remove nut (12) and bolt (13) and remove support strut assembly (14) from plate (15) on hinged roof panel.

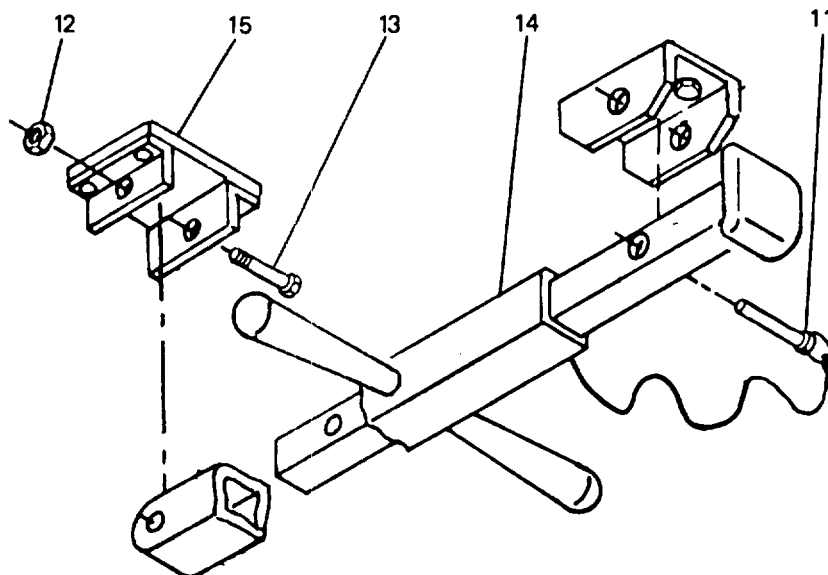

4-20. (cont)

DI SASSEMBLY

Hinged Roof Panel

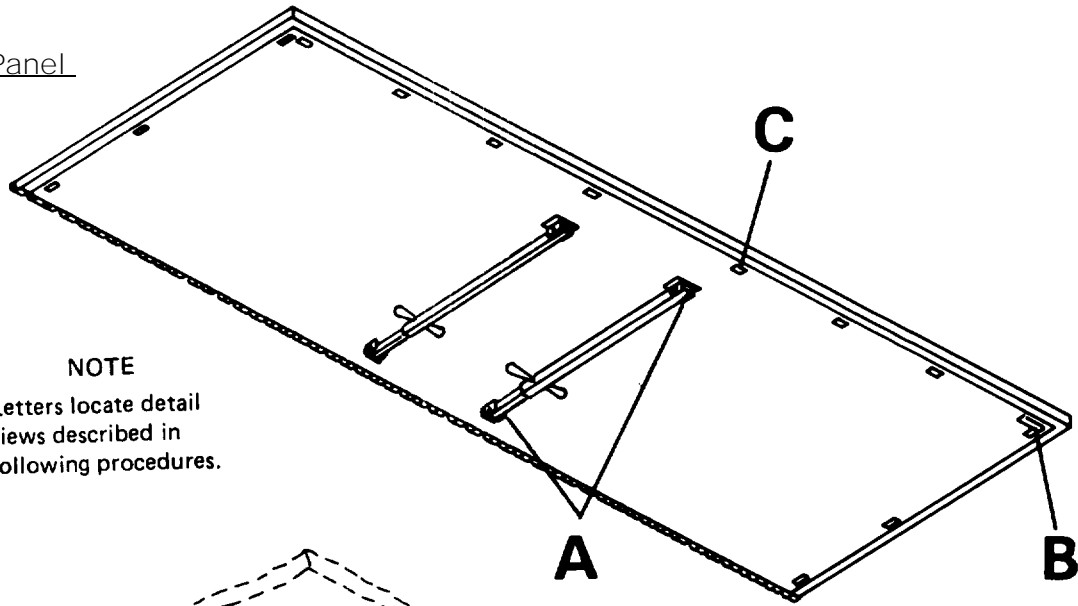

NOTE
Letters locate detail views described in following procedures.

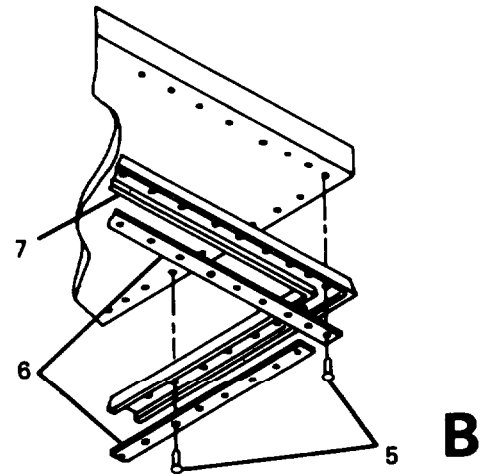
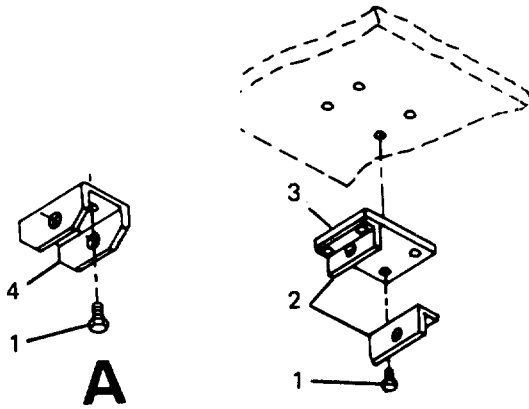

1. Remove screws (1), angles (2), plate (3) and bracket (4) from roof.
2. Drill out rivets (5) securing seal retainer strips (6). (Refer to paragraph 4-32)
3. Remove seal (7). (Refer to paragraph 4-40)
4. Drill out rivets (8) and remove strike cup (9). (Refer to paragraph 4-32)

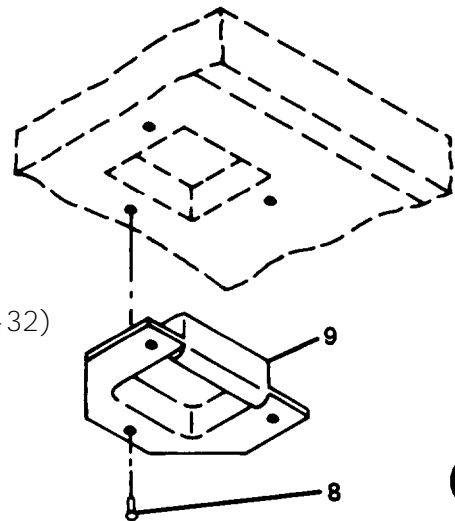

4-20. (cont)

Support Strut Assembly

5. Remove screw (10) and washer (11) and remove pin (12) and lanyard (13) from outer tube assembly (14).
6. Remove tapered handles (15), lockwashers (16), and handle shafts (17) by unscrewing.
7. Remove pad (18) from inner tube assembly (19).
8. Remove outer tube assembly (14) from inner tube assembly (19).

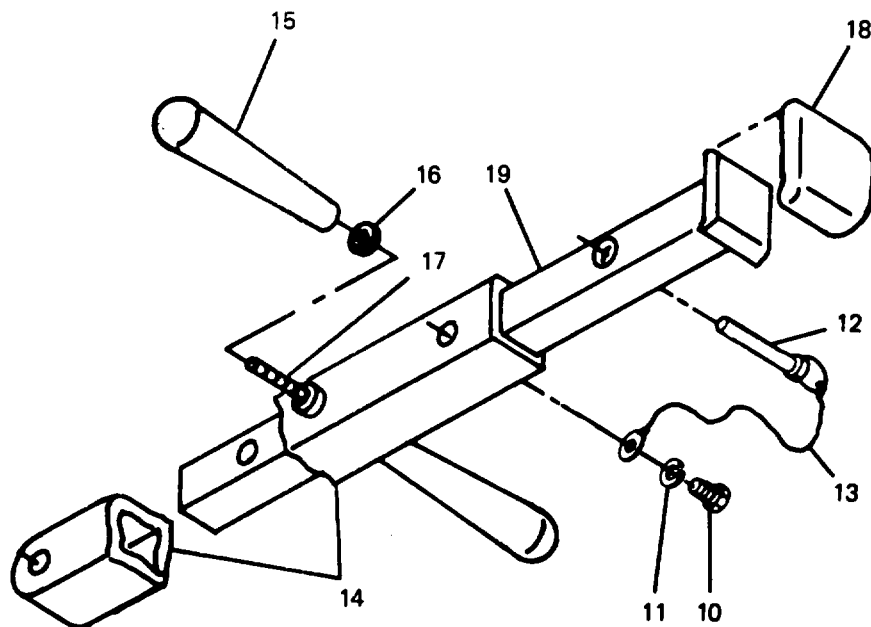

CLEANING, INSPECTION

1. Clean panel and component surfaces.
2. Inspect mounting surfaces for corrosion and damage.
3. Inspect for and replace if necessary:
 - a. Missing or damaged components
 - b. Corrosion or paint damage.

REPAIR

1. Panel skin damage. (Refer to paragraphs 4-31 through 4-42.)
2. Corrosion or paint damage. (Refer to paragraph 4-33)

4-20. (cont)

ASSEMBLY

Support Strut Assembly

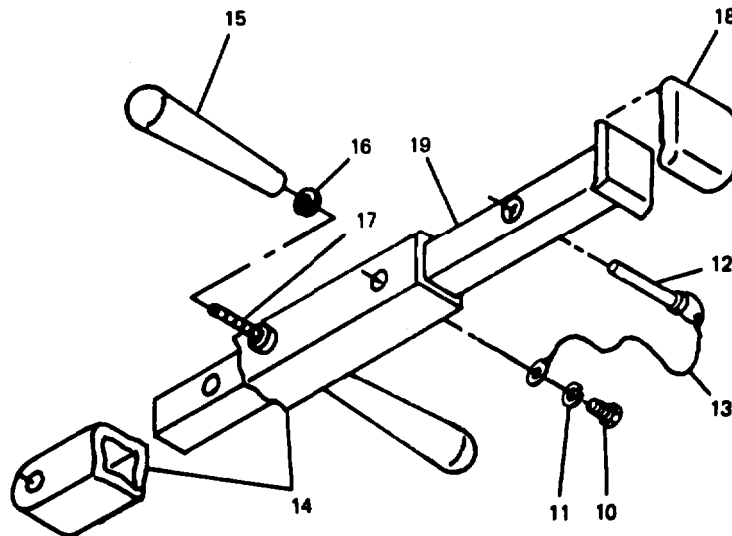

1. Install inner tube assembly (19) in outer tube assembly, (14).
2. Attach pad (18) to inner tube assembly (19) with adhesive.
3. Install handle shafts (17) and lockwashers (16) in outer tube assembly (14) and mount tapered handles (15) on handle shafts (17).
4. Assemble pin (12) and lanyard (13) to outer tube assembly (14) with screw (10) and washer (11).

Hinged Roof Panel

5. Coat strike cup (9) mating surface and roof panel mounting area with adhesive.
6. Position strike cup (9) and install rivets (8). (Refer to paragraph 4-32)
7. Install seal (7) and retainer strips (6) with rivets (5). (Refer to paragraph 4-40)

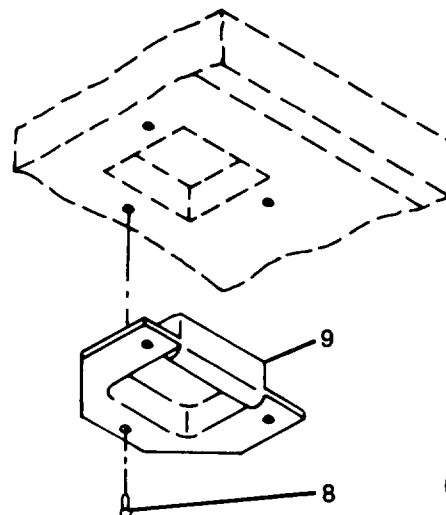

C

4-20. (cont)

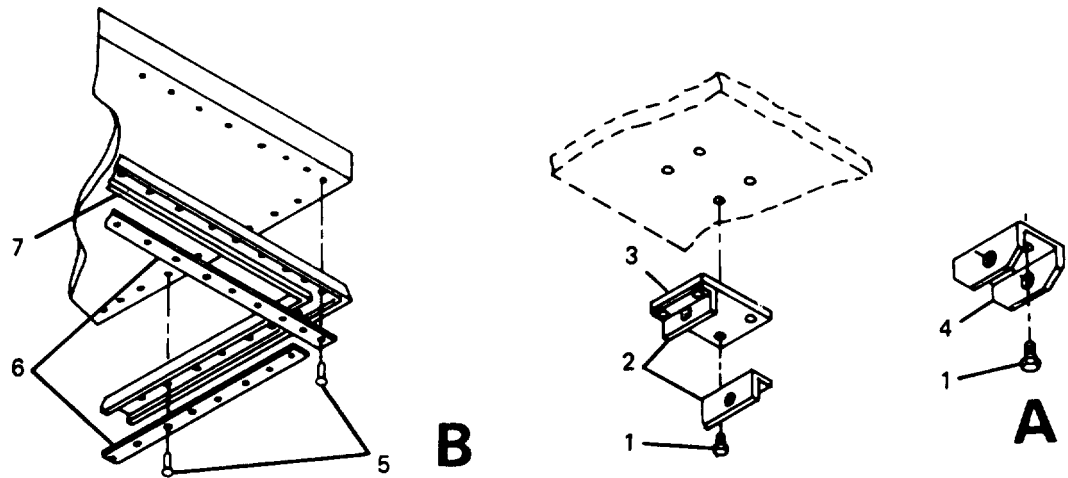

8. Coat bracket (4) and plate (3) and roof panel mounting area with adhesive.
9. Position bracket (4), plate (3), and angles (2) on roof panel and install screws (1).

Support Strut Assembly

1. Secure support strut assembly (14) to plate (15) on hinged roof panel with bolt (13) and nut (12).
2. Raise support strut assembly to horizontal position in strut support bracket (16) on hinged roof panel and install pin (11).

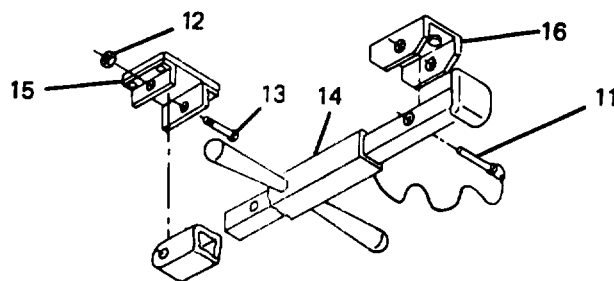

4-20. (cont)

Hinged Roof Panel

3. Coat rollers (8) with silicone grease to hold rollers in place and position rollers in fixed roof hinges.
4. Lift and support hinged roof (11) in stowed position.

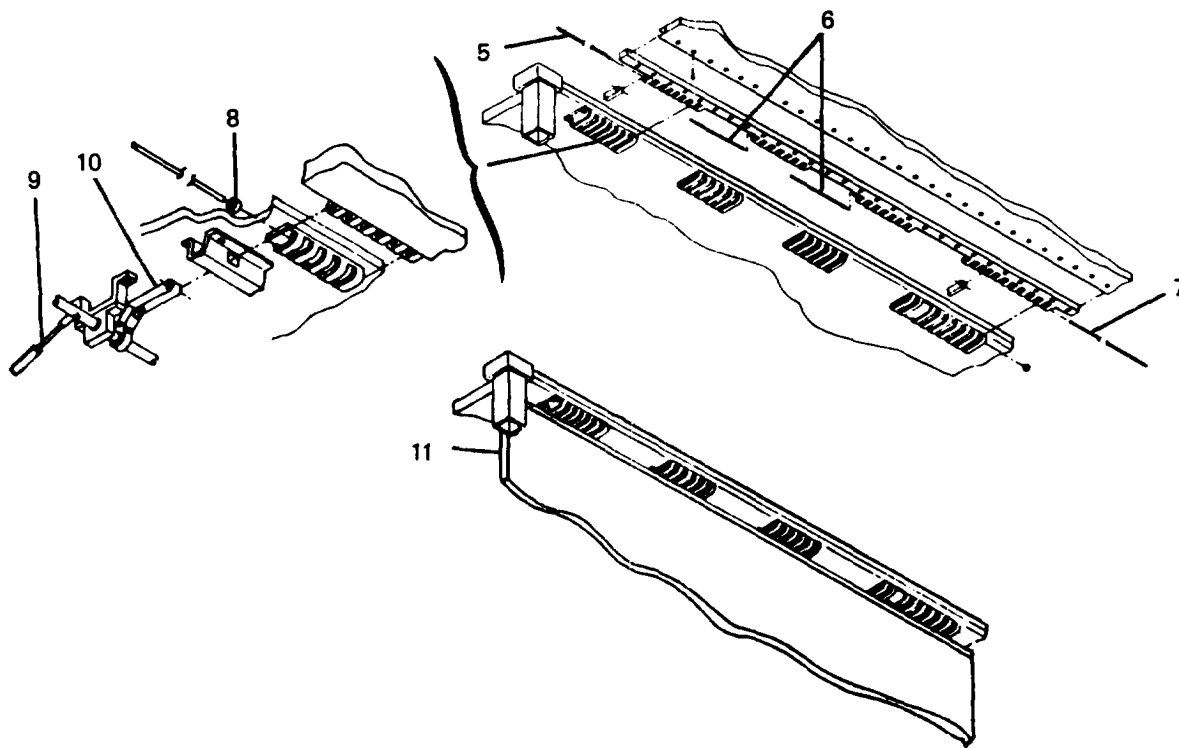

5. Engage hinge with fixed roof hinges.
6. Install hinge pins (5, 6, and 7). Ensure that hinge pins go through rollers (8) and solar bar rods (10).
7. Bend each end of hinge pins approximately 15 degrees to prevent slippage.
8. Push two handles of solar bar (9) simultaneously to slide hinged roof back and forth to check freedom of movement.

4-20. (cont)

ALIGNMENT

Adjust leveling jacks to make sure positioning marks on hinged roof and hinged sidewall are properly aligned. Alignment marks on hinged endwall and hinged sidewall must also align at the same time.

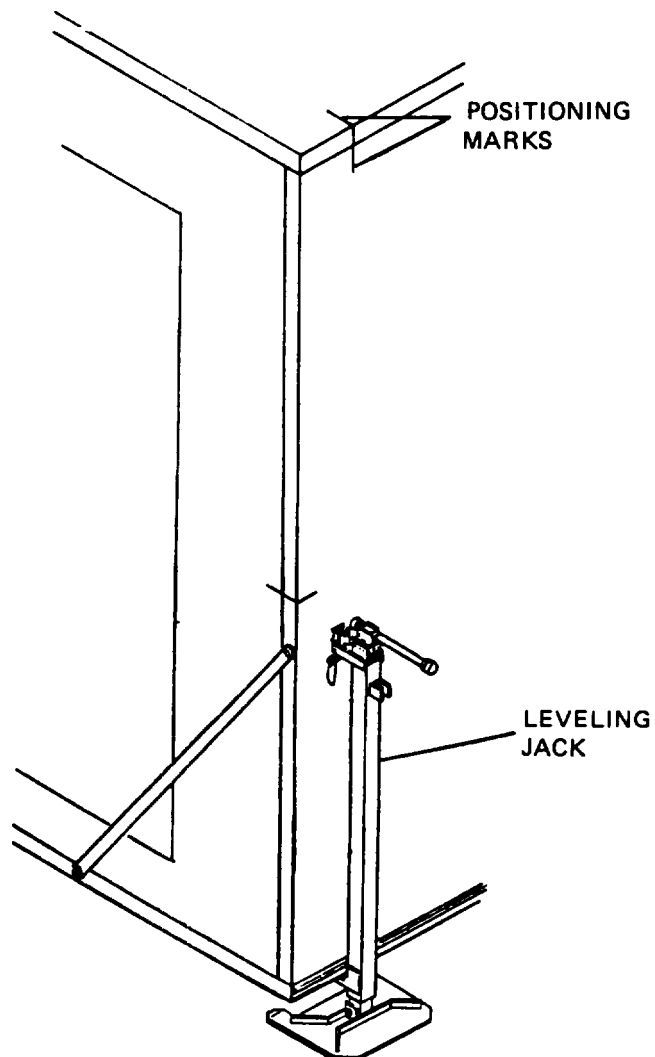

4-21. HINGED ENDWALL REPLACEMENT AND REPAIR

This task covers:

- | | |
|-------------------------|-----------------|
| a. Removal | d. Repair |
| b. Disassembly | e. Assembly |
| c. Cleaning, Inspection | f. Installation |
-

INITIAL SETUP

Special Tools

Hand blind riveter, Appendix B,
Item 2

Standard tools

General mechanics tool kit

Personnel - 4

1 Electrician

Equipment Condition

Closeout panel removed from
hinged endwall

Materials

Adhesive, Item 2, Appendix E
Sealing Compound, Item 19,
Appendix E

NOTE

The following procedures apply to left and right hinged endwalls.

REMOVAL

Hinged Endwall

WARNING

The shelter contains voltages that are dangerous if contacted. Before removing or installing electrical cables or components, make certain electrical power is completely disconnected from circuit involved.

1. Set circuit breakers CB3 and CB7 or CB5 to OFF position.
2. Move receptacles from hinged endwall and stow out of way.
3. Disengage all latches (1) along hinged sidewall, hinged endwalls, and hinged roof.

CAUTION

Support inner tube while disengaging support strut from stowage bracket.

4. Pull lock pins (2) to free support struts (3) from stowage brackets (4) and swing downward.
5. Insert lock pins (2) to secure struts in extended position.

4-21. (cont)

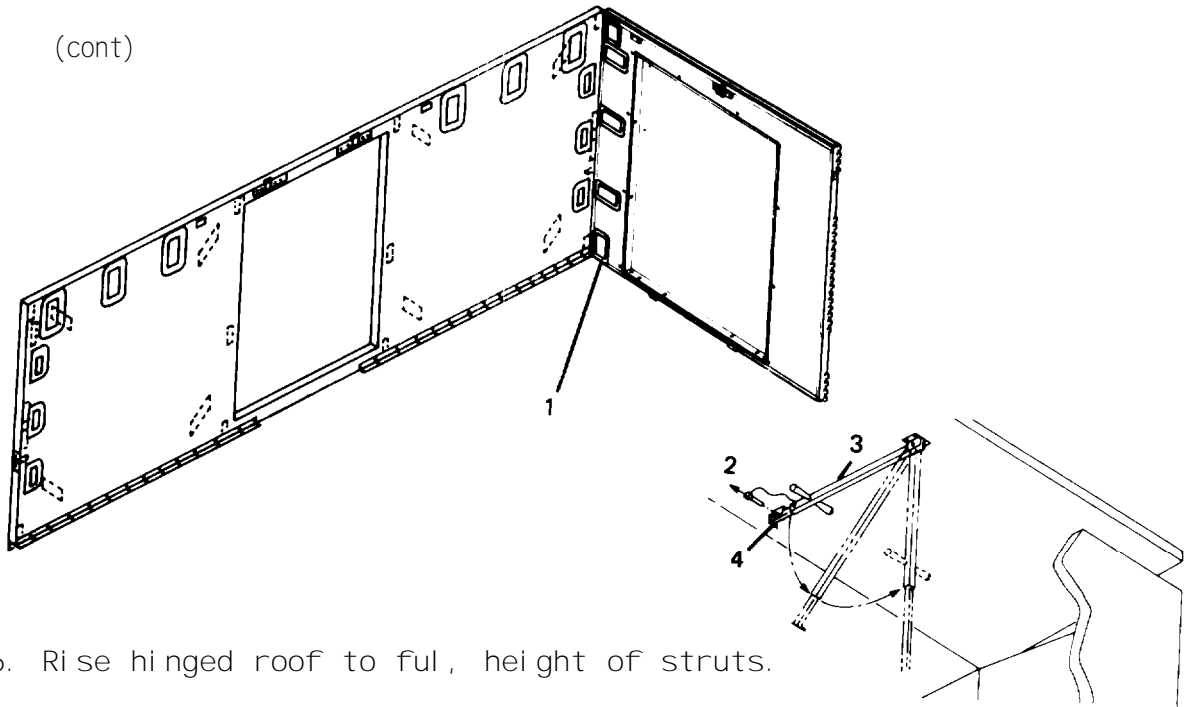

6. Rise hinged roof to full height of struts.
7. Rotate jack handles to lower both expanded side jacks until hinged floor is clear of hinged endwall.
8. Remove screws (5) and lockwashers (6) and remove pin retainer (7) from hinged endwall (10).
9. Support hinged endwall, straighten lower hinge pins, and remove pins (8) and (9).
10. Remove hinged endwall.

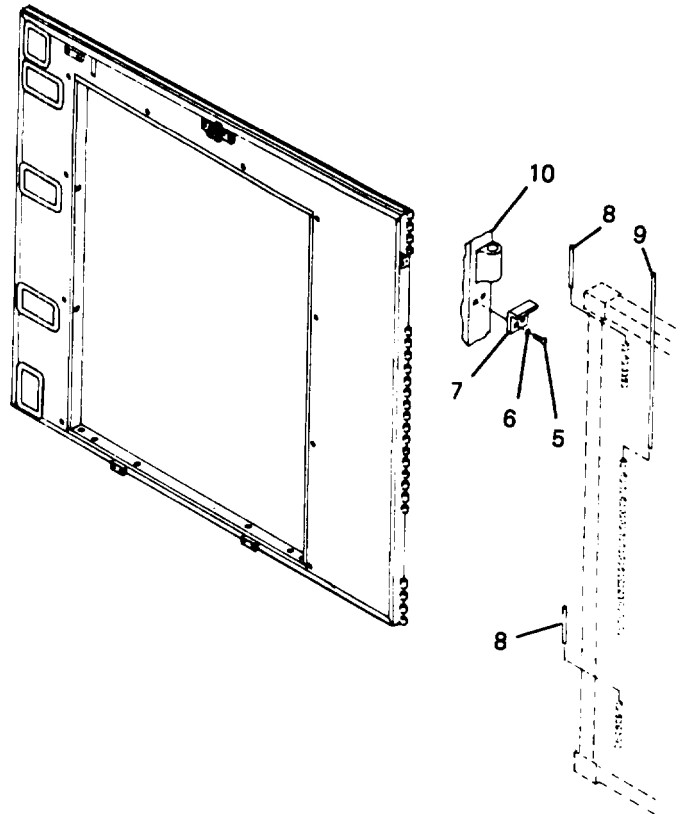

4-21. (cont)

Latch

11. Remove captive screws (11) and latch (12) from hinged endwall.

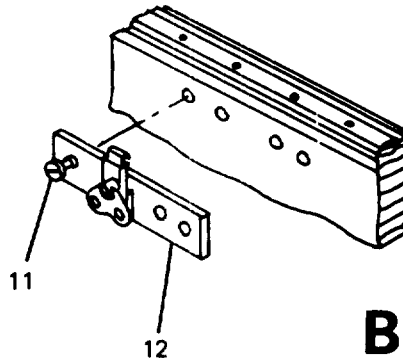

DI SASSEMBLY

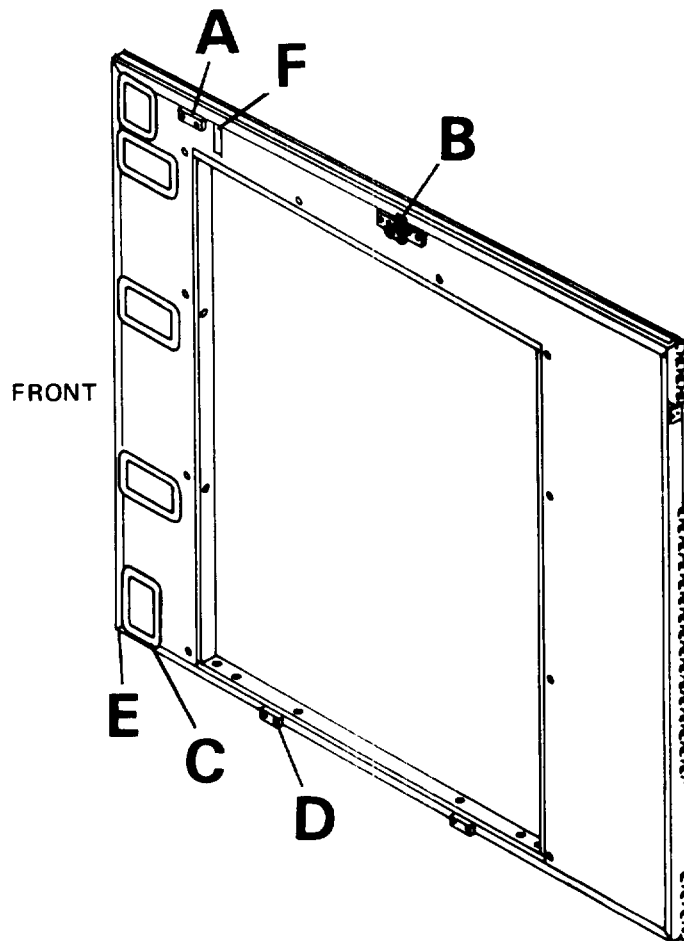

NOTE
Letters locate detail
views described in
following procedures.

4-21. (CONT)

1. Drill out rivets (1) and remove bumper pad (2). (Refer to paragraph 4-32)
2. Remove rivets (3) and (4) and remove latch (5) and latch pan (6). (Refer to paragraph 4-32)
3. Remove screws (7) and remove spacer (8).

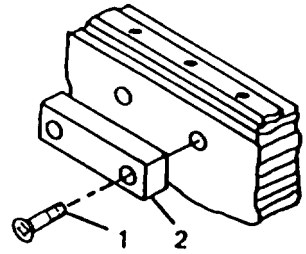

A

NOTE

Step 4 applies to left endwalls only.

4. Drill out rivets (9) and remove retainer strips (10) and (11). (Refer to paragraph 4-32)
5. Remove seal (12). (Refer to paragraph 4-40)
6. Drill out rivets (13) and remove retainer strip (14). (Refer to paragraph 4-32)
7. Remove seal (15). (Refer to paragraph 4-40)
8. Remove velcro strap (16).
9. Drill out rivets (17) and remove retainer strip (18). (Refer to paragraph 4-32)

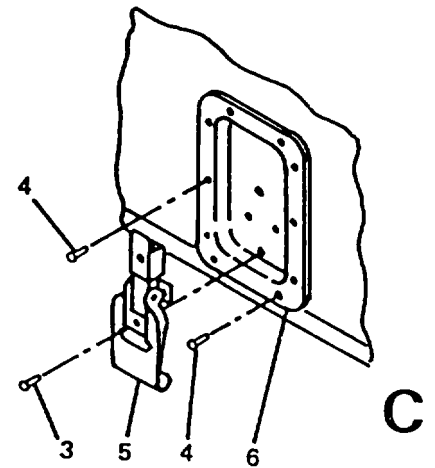

C

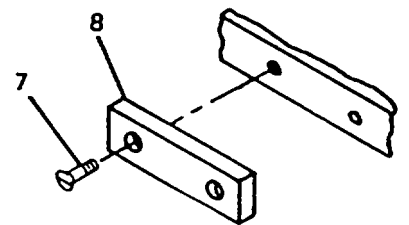

D

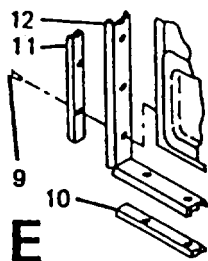

E

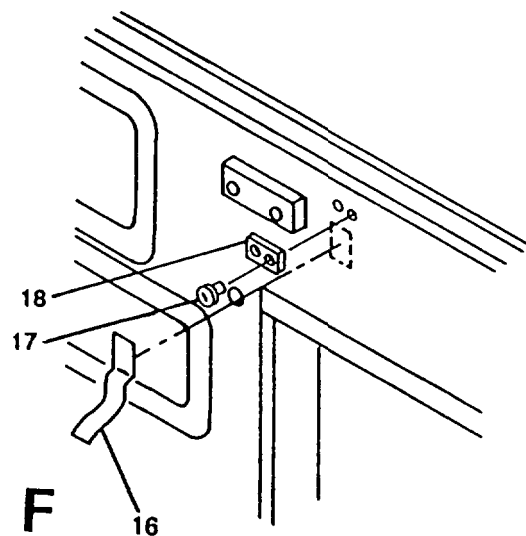
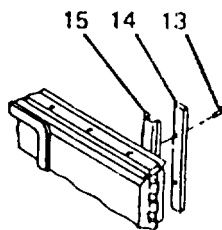

F

4-21. (cont)

10. Remove screws (19) and retainer washers (20) from latch plate (21).
11. Drill out rivets (22) and remove link lock (23) from latch plate (21). (Refer to paragraph 4-32)

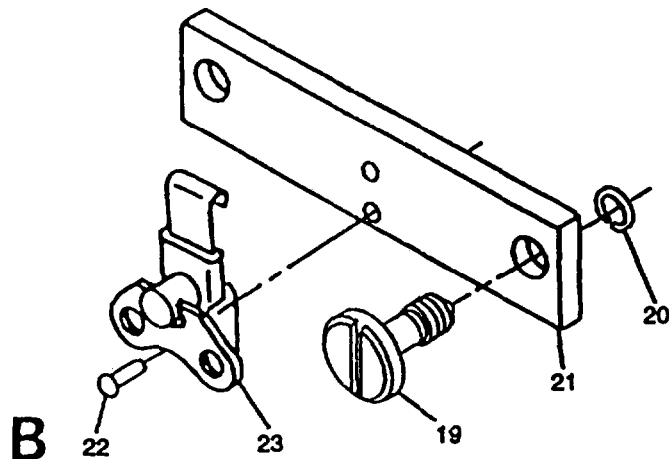

CLEANING, INSPECTION

1. Clean panel and component surfaces.
2. Inspect mounting surfaces for corrosion and damage.
3. Inspect for and replace if necessary
 - a. Missing or damaged components
 - Corrosion or paint damage.

REPAIR

1. Panel skin damage. (Refer to paragraphs 4-31 through 4-42.)
2. Corrosion or paint damage. (Refer to paragraph 4-43)

ASSEMBLY

Latch

1. Position link lock (23) on latch plate (21) and secure with rivets (22). (Refer to paragraph 4-32)
2. Install screws (19) and retainer washers (20) in latch plate (21).

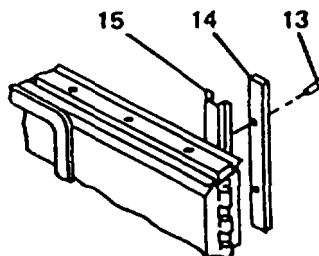

4-21. (cont)

Hinged Endwall I

3. Install retainer strip (18) with rivets (17). (Refer to paragraph 4-32)
4. Install seal (15) and retainer strip (14) with rivets (13). (Refer to paragraph 4-40)
5. Install seal (12) and retainer strips (10 and 11) with rivets (9). (Refer to paragraph 4-40)

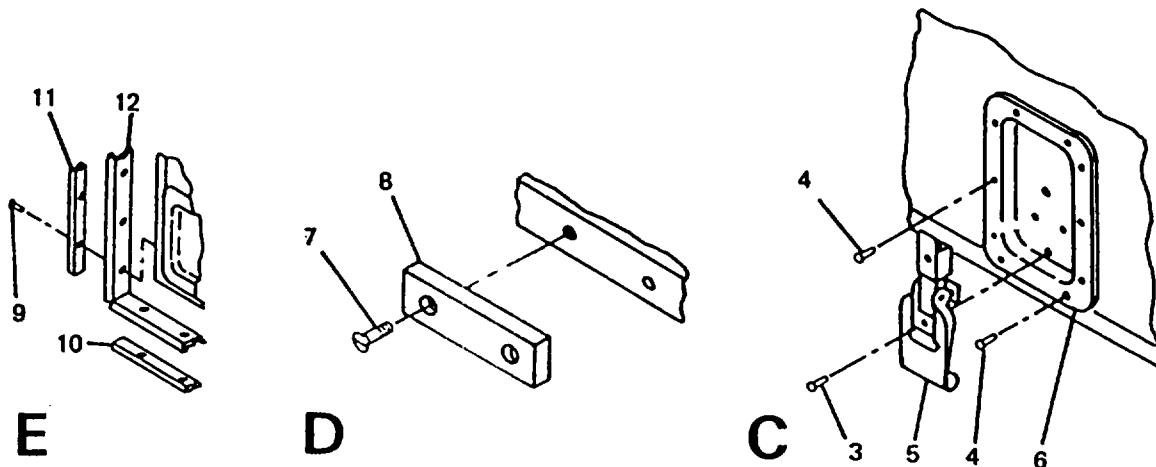

6. Position spacer (8) and install screws (7).
7. Position latch (5) and install rivets (3).
8. Position latch pan (6), bond with adhesive, and install rivets (4). (Refer to paragraph 4-32)
9. Position bumper pad (2) and install rivets (1), (Refer to paragraph 4-32)
10. Bond velcro strap (16) to endwall panel with adhesive.

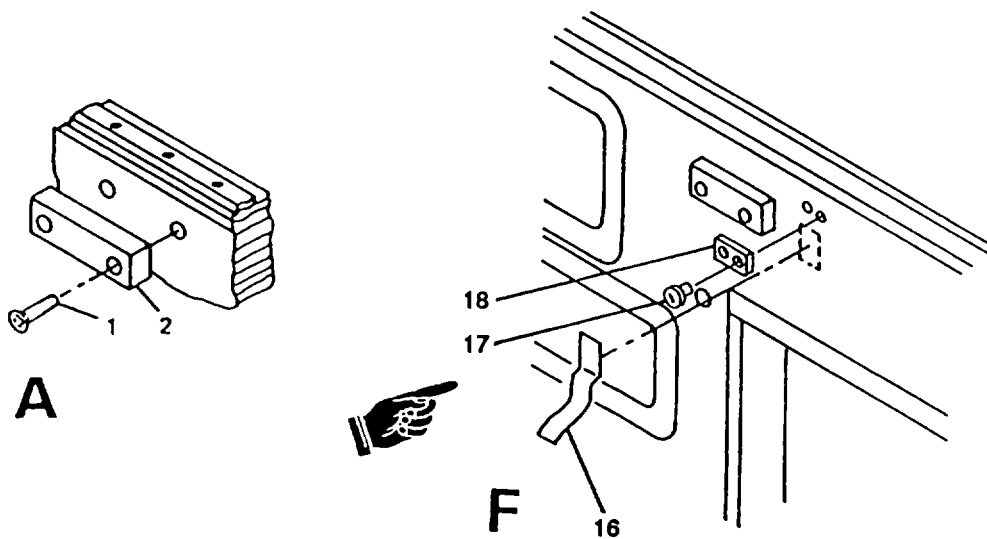

4-21. (cont)

INSTALLATION

1. Position and support hinged endwall to align hinges (10).
2. Install hinge pins (8) and (9). Bend top of center and lower hinge pins approximately 15 degrees.
3. Install pin retainer (7) with lockwashers (6) and screws (5) to secure upper hinge pin.

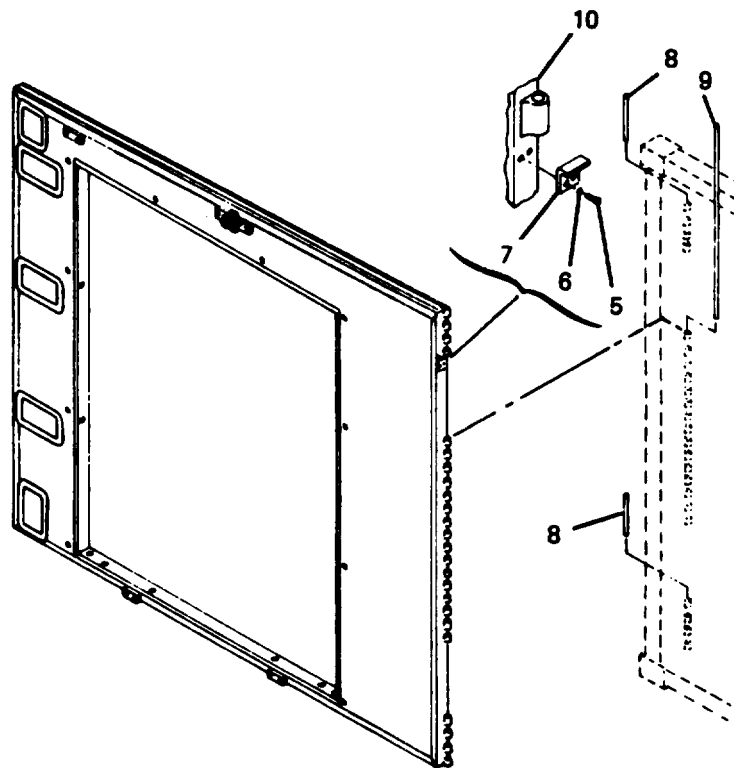

4. Swing hinged endwall inward and back to check for freedom of movement.
5. Complete extension of expandable side by performing steps x through ae of paragraph 2-12.
6. Move receptacles from temporary stowed position and mount on hinged endwall.

4-22. HINGED SIDEWALL REPLACEMENT AND REPAIR

This task covers:

- | | |
|-------------------------|-----------------|
| a. Removal | d. Repair |
| b. Disassembly | e. Assembly |
| c. Cleaning, Inspection | f. Installation |

INITIAL SETUP

Special Tools

Hand blind riveter, Appendix B, Item 2
Snap ring pliers, Appendix B, Item 10
Installation tool, Appendix B, Item 3
Installation tool, Appendix B, Item 14
Electric drill; portable, Appendix B, Item 6

Standard Tools

General mechanics tool kit

Personnel - 4

1 Electrician

Equipment Condition

Equipment Condition

Closeout and ECU panels removed from hinged sidewalls

Materials

Adhesive, Item 1, Appendix E
Adhesive, Item 2, Appendix E
Adhesive, Item 3, Appendix E
Sealant, Item 18, Appendix E
Sealing Compound, Item 19, Appendix E
Spray Lubricant, Item 25, Appendix E

NOTE

The following procedures apply to left and right hinged sidewalls.

REMOVAL

Hinged Sidewall

WARNING

The shelter contains voltages that are dangerous if contacted. Before removing or installing electrical cables or components, make certain electrical power is completely disconnected from circuit involved. Support cables must be locked out prior to removal of hinged sidewall.

NOTE

Remove only those electrical components that will interfere with removal of a particular panel.

1. Install support braces.
2. Set circuit breaker CB3 and CB7 or CB5 to OFF position.

4-22. (cont)

3. Move receptacle assemblies and stow on hinged endwall.
4. Set circuit breaker CB6 to OFF position.
5. Disconnect and remove three hinged roof area ceiling lights. Stow light assemblies in fixed ceiling storage brackets. (Refer to para. 3-5)
6. Disengage all latches (1) along hinged sidewall, hinged endwalls, and hinged roof.
7. Remove all removable latches and retain.

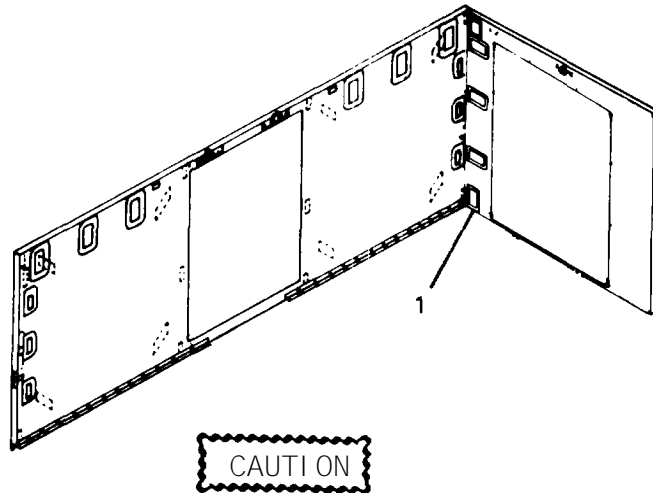

Support inner tube while disengaging support strut from stowage bracket.

8. Pull lock pins (2) to free support struts (3) from stowage brackets (4) and swing downward.
9. Insert lock pins (2) to secure struts in extended position.
10. Raise hinged roof to full height of struts.
11. Rotate jack handles to lower both expanded side jacks until hinged floor is clear of hinged endwalls.
12. Swing both hinged endwalls inward to stowed positions.
13. Lower hinged roof.
14. Stow support struts on hinged roof.
15. Slide hinged roof inward with solar bar.
16. Lower jacks to disengage from jack support brackets on hinged sidewall.

4-22. (cont)

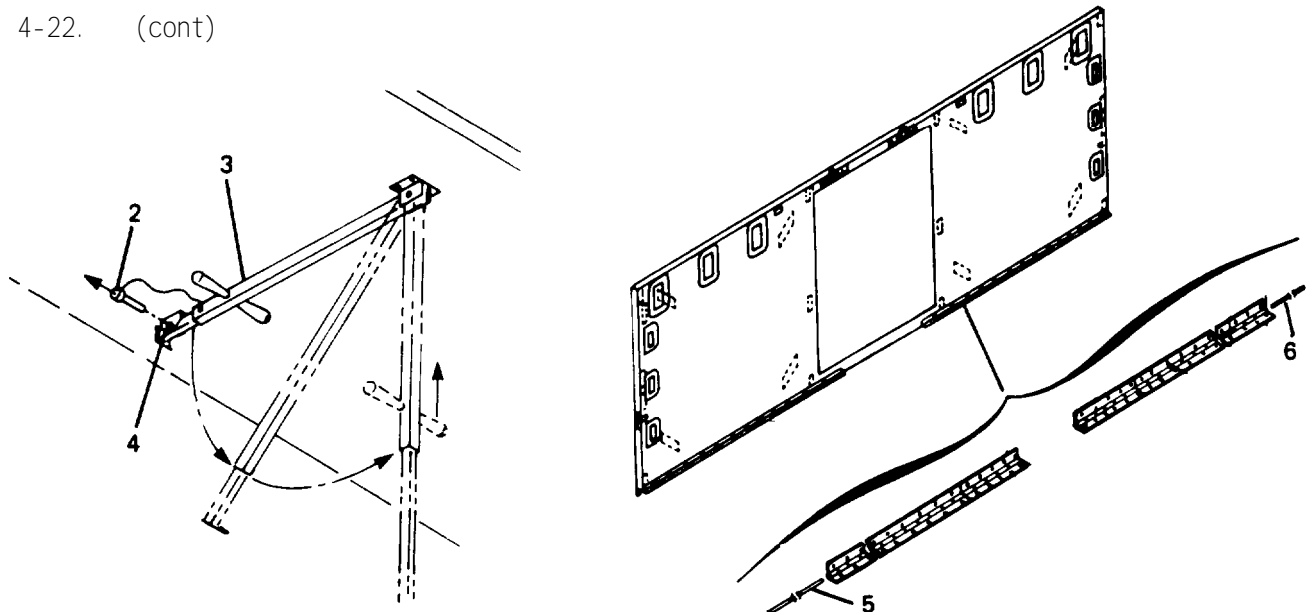

17. Lower hinged sidewall to hinged floor.

18. Remove hinge pins (5) and (6) by first lubricating with spray lubricant, then driving it toward the center. Use a variable speed drill motor to pull the hinge pin all the way out of the hinge.

19. Remove hinged sidewall.

DI SASSEMBLY

Hinged Sidewall

NOTE
Letters locate detail views described in following procedures.

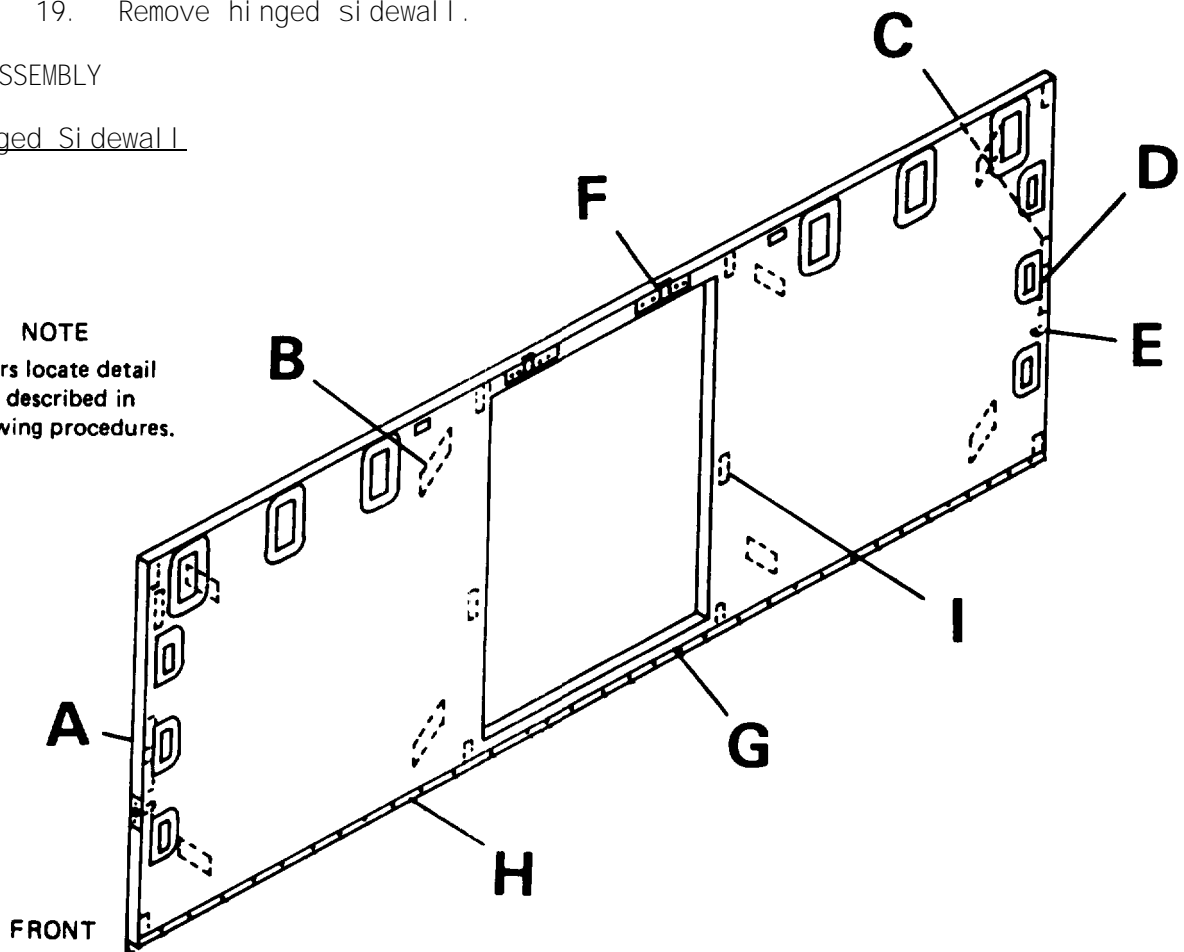

4-22. (cont)

1. Remove screws (1) and remove jack support bracket (2).
2. Drill out rivets (3) and remove bumper pad (4). (Refer to paragraph 4-32)
3. Remove screws (5) and remove stowage bracket (6). (Right hinged sidewall only.)
4. Remove bolts (7), lockwashers (8), and washers (9) and remove strap (10).
5. Drill out rivets (11) and remove brace cup (12). (Refer to paragraph 4-32)
6. Drill out rivets (13) and remove latch (14) and latch pan (15). (Refer to paragraph 4-32)
7. Drill out rivets (16) and remove strike cup (17). (Refer to paragraph 4-32)
8. Drill out rivets (18) and remove retainer strip (19). (Refer to paragraph 4-32)
9. Remove screws (20) and latch (21).
10. Remove screws (22) and spacer (23).

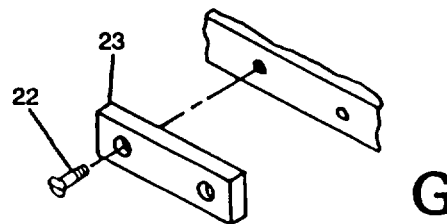
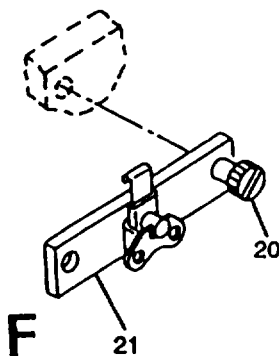
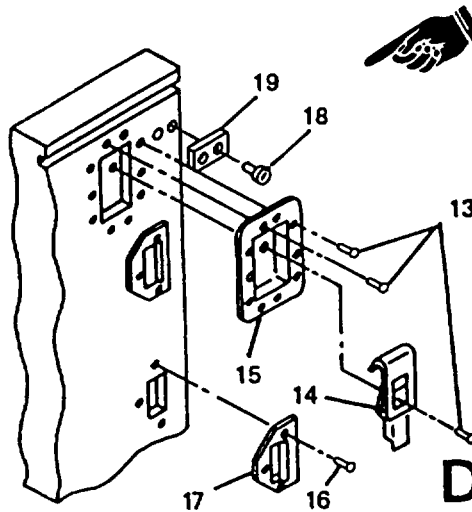
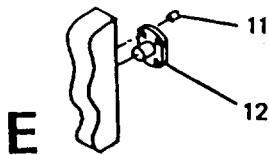
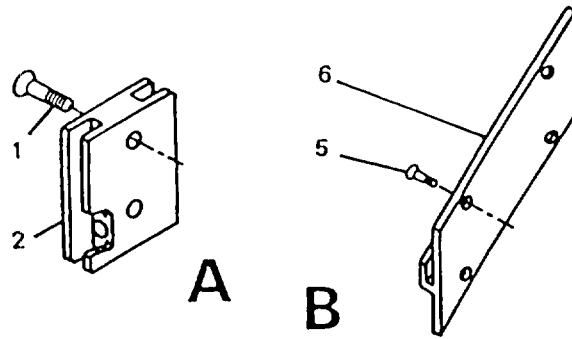

4-22. (cont)

11. Drill out three rivets at threshold. (Refer to paragraph 4-32)
12. Remove hinge pins (24) by first lubricating with silicone grease, then driving it out toward the center part way. Use a drill motor to pull the hinge pin all the way out of the hinge.
13. Drill out rivets (25) and remove hinges (26 and 27). (Refer to paragraph 4-32)

NOTE

The rivets on each end of the hinges are special high strength rivets and require the use of installation tool, Appendix B, Item 14.

14. Drill out rivets (28) and remove retainer strip (29) and seal (30). (Refer to paragraph 4-40)

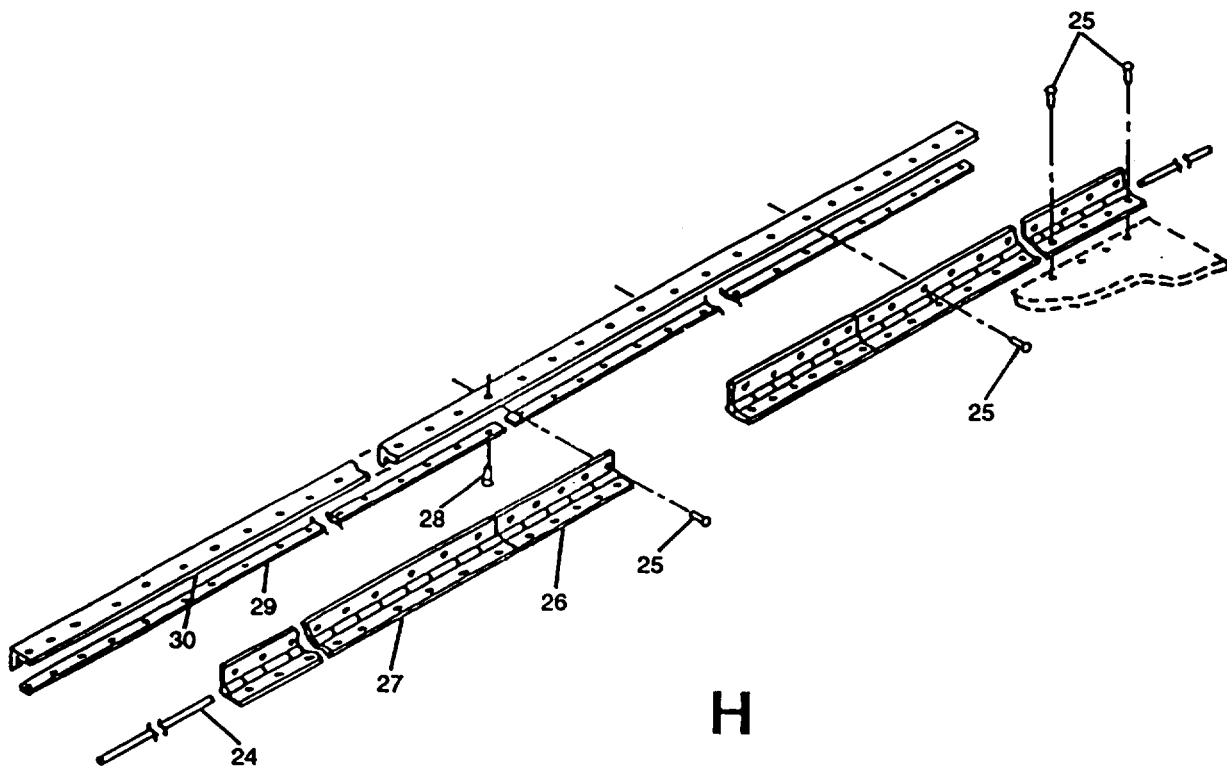

4-22. (cont)

Sidewall Closeout panel

15. Remove captive screw (31) and two washers (32) at each of four locations on ECU intake and return closeout panels (34).
16. Remove weather seals (33) from ECU intake and/or return closeout panels (34). (Refer to paragraph 4-40)
17. Remove screws (35) and using snap ring pliers remove retaining rings (36) from closeout panels (37 and 38).
18. Drill out rivets (39) and remove recessed handle (40) from closeout panels (37 and 38). (Refer to paragraph 4-32)
19. Drill out rivets (41) and remove stowage brackets (42) from stowage bracket pan (43). (Refer to paragraph 4-32)
20. Drill out rivets (44) and remove stowage bracket pan (43) from closeout panels (37 and 38). (Refer to paragraph 4-32)
21. Drill out rivets (45) and remove retainer strips (46) from closeout panels (37 and 38). (Refer to paragraph 4-32)

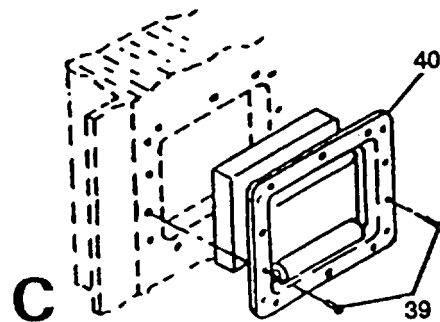
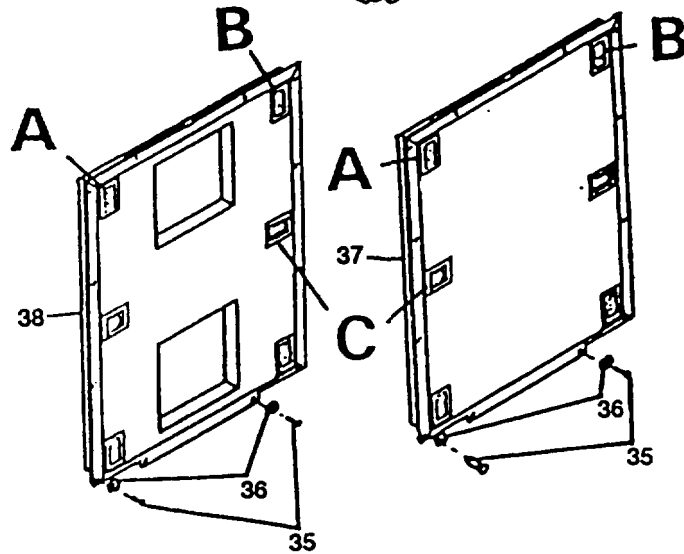
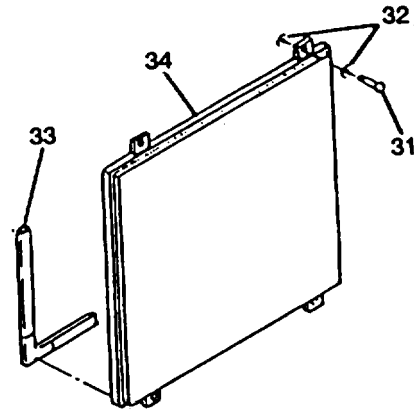

4-22. (cont)

22. Remove weather seals (47) from closeout panels (37 and 38). (Refer to paragraph 4-40)
23. Drill out rivets (48) and remove retaining strips (49) from frame (50). (Refer to paragraph 4-32)

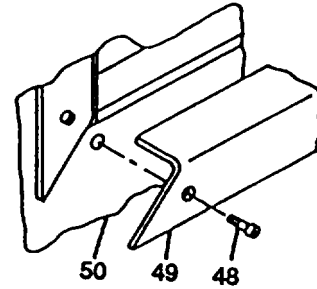

ECU Intake Panel

24. Punch out captive screw (51) and two washers (52) at each of four locations on ECU intake panel (53).
25. Remove weather seal (54) from ECU intake panel (53). (Refer to paragraph 4-40)
28. Drill out rivets (55) and remove vent cover grill (58) from ECU intake panel (53). (Refer to paragraph 4-32)

ECU Return Panel

27. Remove captive screw (57) and two washers (58) at each of four locations on ECU return panel (59).
28. Remove weather seal (80) from ECU return panel. (Refer to paragraph 4-40)

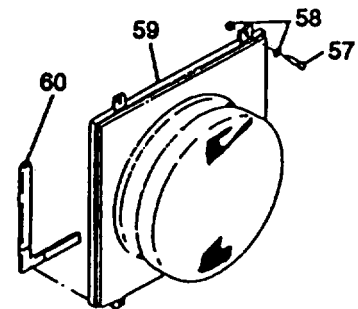
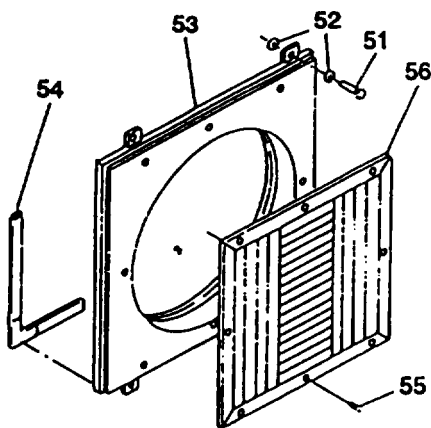

4-22. (cont)

CLEANING, INSPECTION

1. Clean panel and component surfaces.
2. Inspect mounting surfaces for corrosion and damage.
3. Inspect for and replace if necessary:
 - a. Missing or damaged components
 - b. Corrosion or paint damage.

REPAIR

1. Panel skin damage. (Refer to paragraphs 4-31 through 4-42)
2. Corrosion or paint damage. (Refer to paragraph 4-43)

ASSEMBLY

1. Attach weather seal (60) to ECU return panel (59) with adhesive. (Refer to paragraph 4-40)
2. Using installation tool, Appendix B, Item 3, assemble two washers (58) and captive screw (57) at each of four locations on ECU return panel (59).

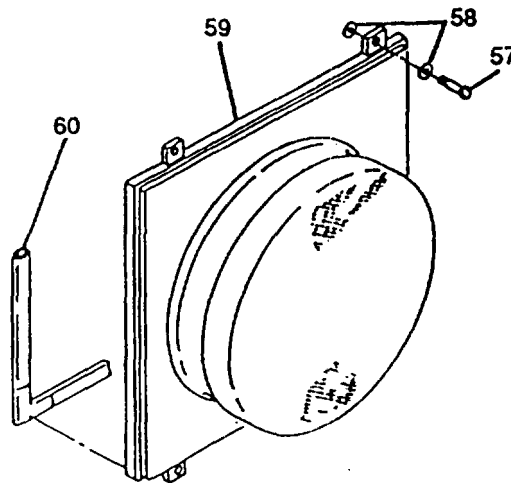

ECU Intake Panel

3. Position vent cover grill (56) on ECU intake panel (53) and secure with rivets (55). (Refer to paragraph 4-32)
4. Attach weather seal (54) to ECU intake panel (53) with adhesive. (Refer to paragraph 4-40)

4-22. (cont)

- Using installation tool, Appendix B, Item 3, assemble two washers (52) and captive screw (51) at each of four locations on ECU intake panel (53).

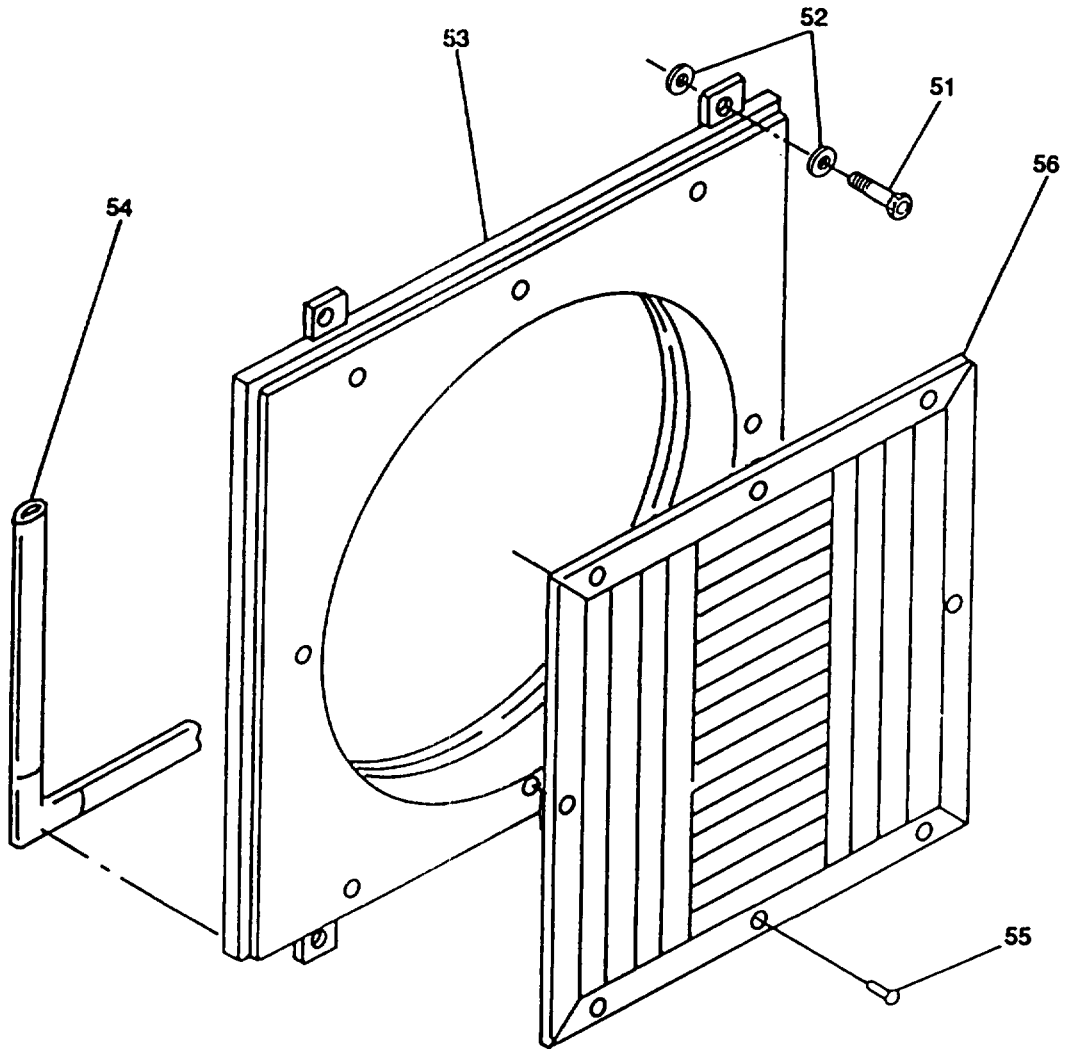

Side Wall Closeout Panels

- Position retaining strips (49) on frame (50) and secure with rivets (48). (Refer to paragraph 4-32)

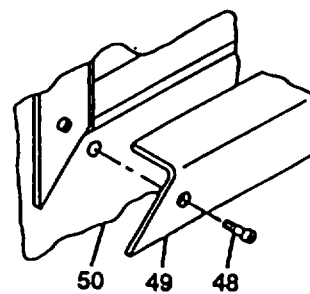

4-22 (cont)

7. Attach weather seals (47) to closeout panels (37 and 38) with adhesive. (Refer to paragraph 4-40)
8. Position retainer strips (46) on closeout panels (37 and 38) secure with rivets (45). (Refer to paragraph 4-32)
9. Position stowage brackets (42) on stowage bracket pans (43) and secure with rivets (41). (Refer to paragraph 4-32)

NOTE

There are left hand and right hand stowage brackets. Assemble in proper location.

10. Position stowage bracket pans (43) on closeout panels (37 and 38), bond with adhesive, and secure with rivets (44). (Refer to paragraph 4-32)
11. Position recessed handle (40) on closeout panels (37 and 38), bond with adhesive, and secure with rivets (39). (Refer to paragraph 4-32)

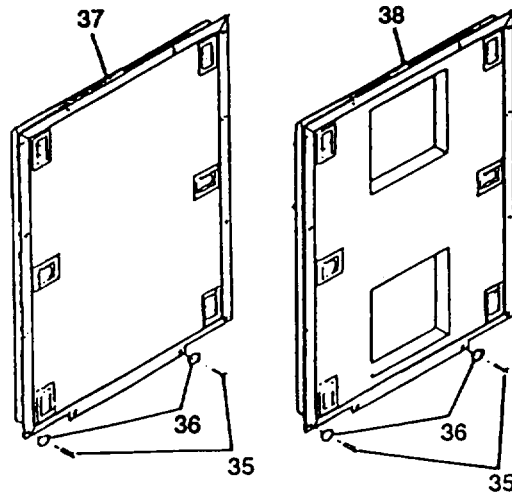
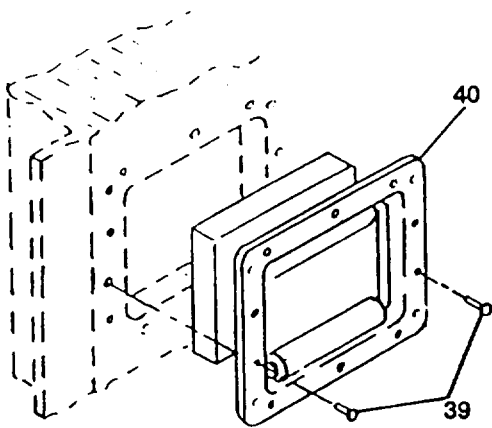
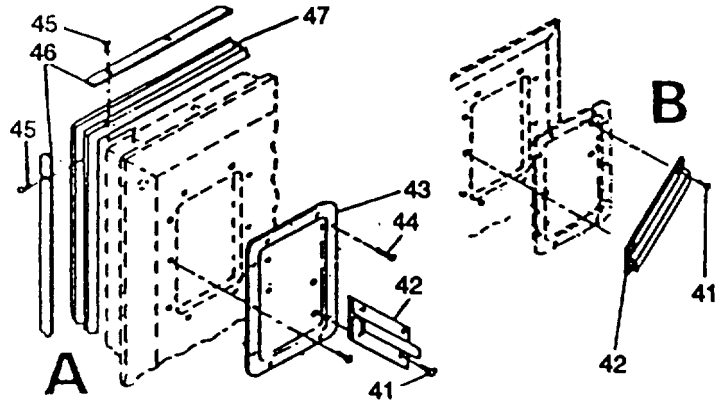
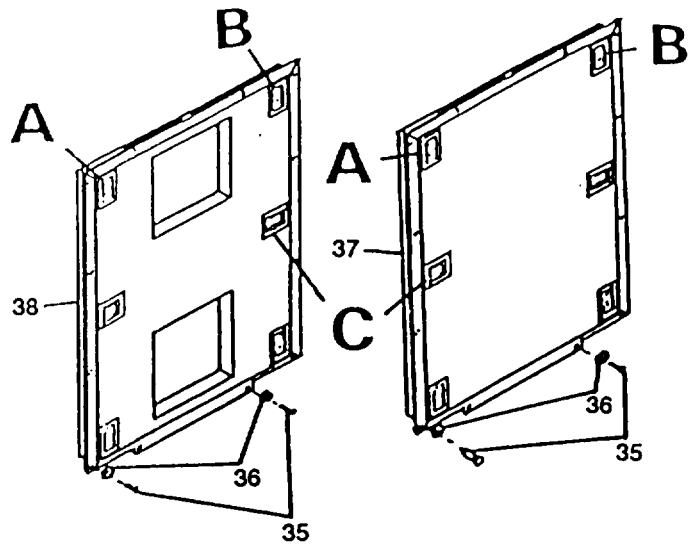

4-22. (cont)

12. Using snap ring pliers, install retaining rings (36) and screws (35) in closeout panels (37 and 38).
13. Attach weather seals (33) to ECU intake and return closeout panels (34). (Refer to paragraph 4-40)
14. Using snap ring pliers, assemble two washers (32) and captive screw (31) at each of four locations on ECU intake and return closeout panels (34).

Hinged Sidewall

15. Assemble retainer strip (29) and seal (30) and secure with rivets (28). (Refer to paragraph 4-40)

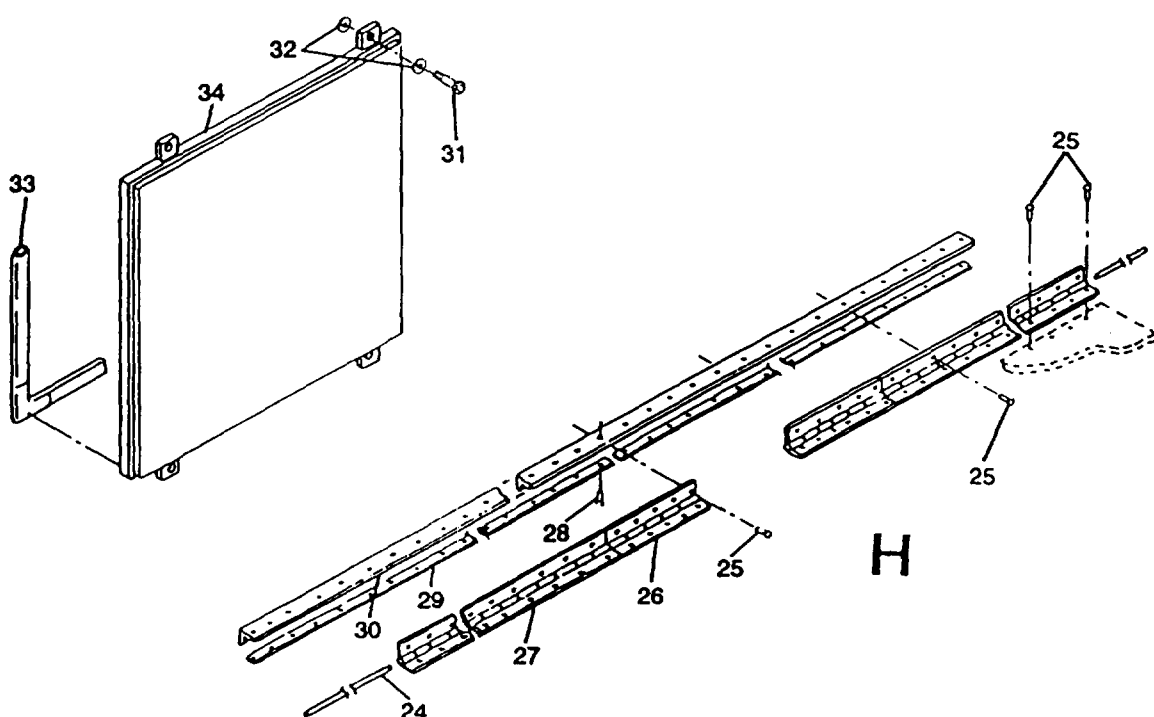

16. Assemble hinges (26 and 27) and secure with rivets (25). (Refer to paragraph 4-32)

NOTE

The rivets on each end of the hinges are special high strength rivets and require the use of installation tool, Appendix B, Item 14.

4-22. (cont)

17. Insert three rivets at threshold. (Refer to paragraph 4-32)
18. Position spacer (23) and install screws (22).
19. Position latch (21) and install screws (20).
20. Position retainer strip (19) and install rivets (18). (Refer to paragraph 4-32)
21. Coat strike cup (17) and latch pan (15) mating surfaces and sidewall panel mounting areas with adhesive,
22. Position strike cup (17) and install rivets (16). (Refer to paragraph 4-32)
23. Position latch pan (15) and latch (14) and install rivets (13). (Refer to paragraph 4-32)

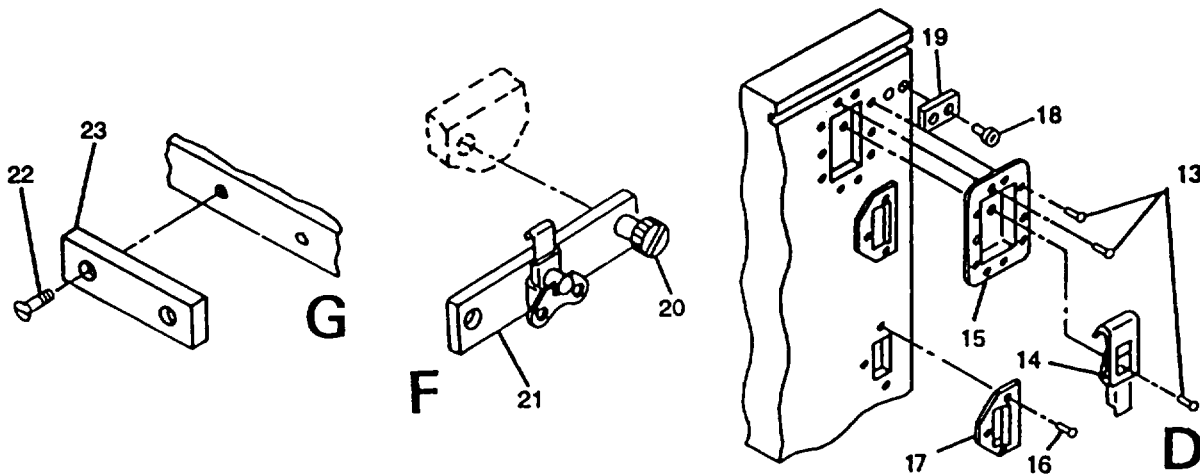

24. Position brace cup (12) and install rivets (11), (Refer to paragraph 4-32)
25. Coat strap brackets with sealant.
26. Position strap (10) and install with washers (9), Lockwashers (8), and bolts (7).
27. Position stowage bracket (6) and install screws (5). (Right sidewall only.)
28. Position bumper pad (4) and install rivets (3). (Refer to paragraph 4-32)
29. Position jack support bracket (2) and install screws (1).

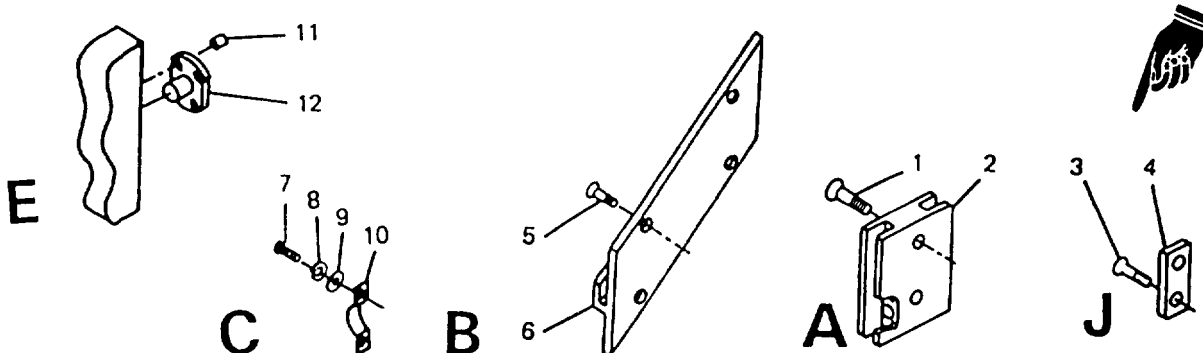

4-22. (cont)

INSTALLATION

1. Position replacement hinged sidewall on hinged floor with inside of sidewall down.
2. Install hinge pins (5) and (6), by first lubricating with spray lubricant, then driving it toward outside. Use a variable speed drill motor to drive the hinge pins all the way in the hinge.
3. Raise and lower sidewall to check for freedom of movement.
4. Raise hinged sidewall and hold in position.
5. Install two braces in brace cups on hinged floor and endwall.
6. Complete extension of expandable side by performing steps n through ae of paragraph 2-12.
7. Install three hinged roof area ceiling lights. (Refer to paragraph 3-5)
8. Move receptacle assemblies from temporary stowed position and mount on hinged sidewall.

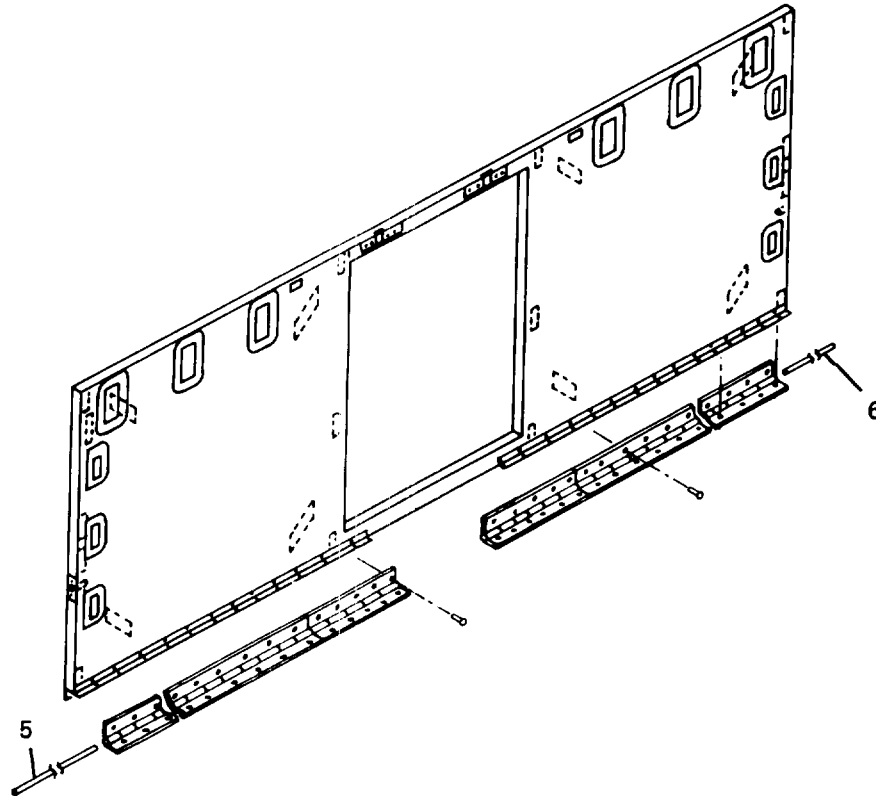

4-23. HINGED FLOOR PANEL REPLACEMENT AND REPAIR

This task covers:

- | | |
|-------------------------|-----------------|
| a. Removal | d. Repair |
| b. Disassembly | e. Assembly |
| c. Cleaning, Inspection | f. Installation |
-

INITIAL SETUP

Special tools

Hand blind riveter, Appendix B, Item 2

Standard Tools

General mechanics tool kit

Personnel - 4

1 Electrical

Materials

Adhesive, Item 3, Appendix E

Sealing Compound, Item 19,

Appendix E

REMOVAL

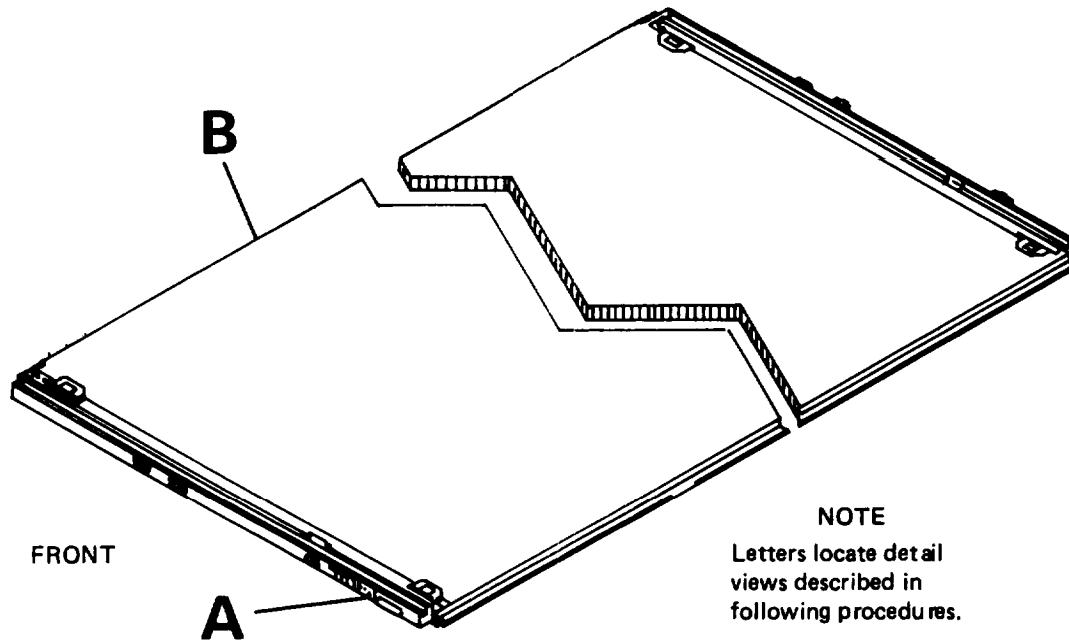

1. Remove hinged sidewall in accordance with paragraph 4-22.
2. Close stop plates on both load balancers mounted on fixed roof.
3. Lift hinged floor to remove weight from support cables.

WARNING

When hinged floor is in deployed position, do not disconnect support cable from hinged floor until stop plates on load balancer (inside shelter) have been locked with quick release pins to prevent return of support cable.

4-23. (cont)

4. Remove screws (1) from two cable guide brackets (2) and disengage support cables.

NOTE

Hinged floor needs to be in stowed position to remove seal and hinged sidewall removed (paragraph 4-22) to remove hinge.

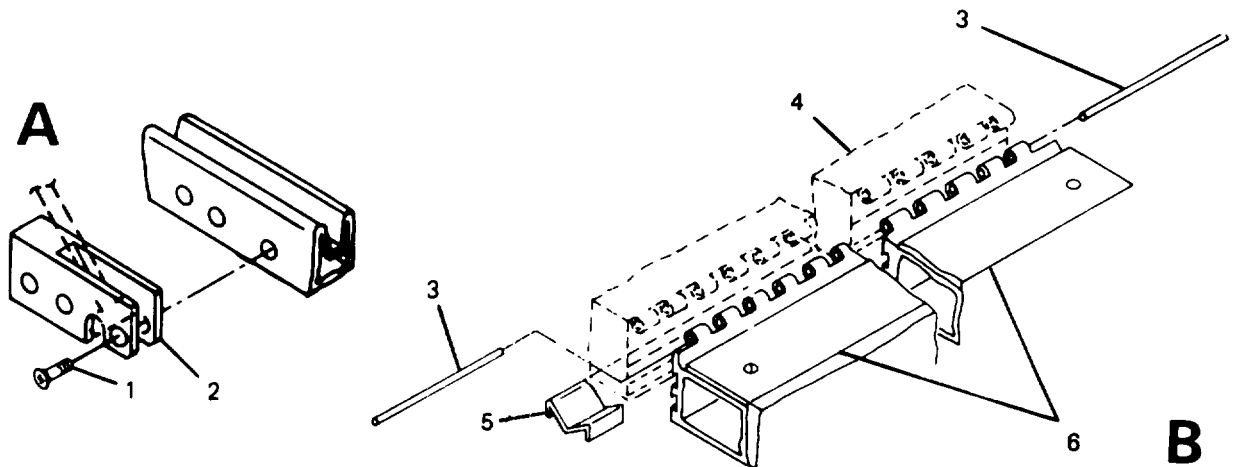

5. Peel off seal (5).
6. Remove two hinge pins (3).
7. Disengage hinged floor from fixed floor hinge (4).

DISASSEMBLY

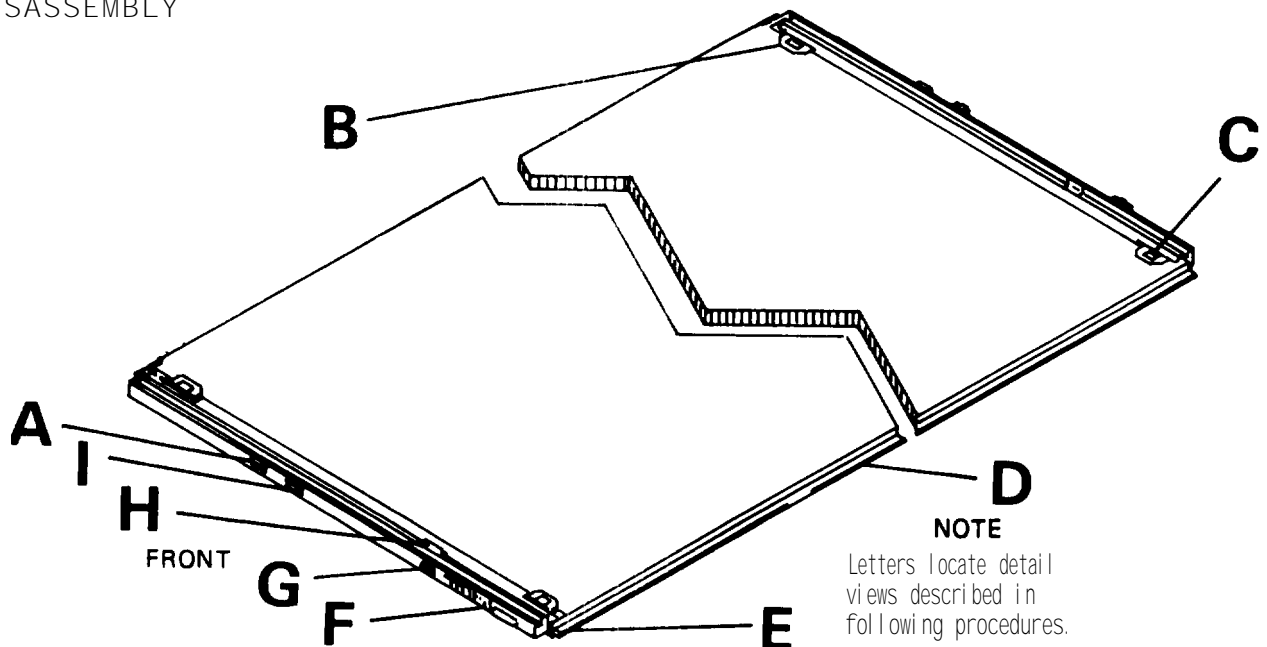

4-23. (cont)

1. Remove screws (1) and washers (2) and remove cam strike (3).

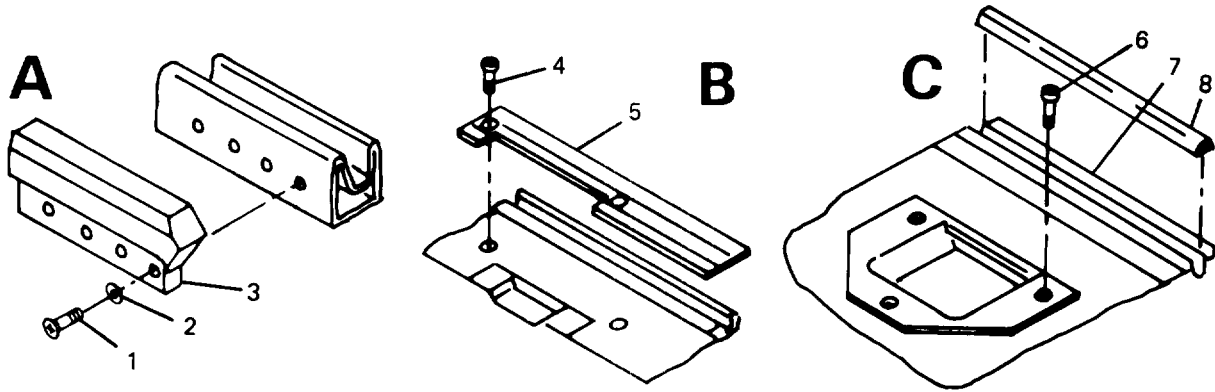

2. Drill out blind rivets (4) and remove threshold (5). (Refer to paragraph 4-32)
3. Drill out blind rivets (6) and remove strike cup (7). (Refer to paragraph 4-32)
4. Peel off seal (8).

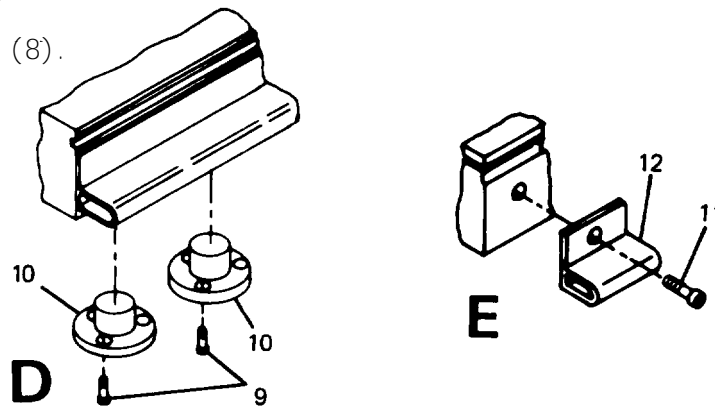

5. Drill out blind rivets (9) and remove grommets (10). (Refer to paragraph 4-32)
6. Drill out blind rivets (11) and remove closeout seal (12). (Refer to paragraph 4-32)
7. Remove screws (13) from cable guide bracket (14).
8. Drill out blind rivets (15) and remove brace cup (16). (Refer to paragraph 4-32)
9. Drill out blind rivets (17) and remove stop angle (18). (Refer to paragraph 4-32)

4-23. (cont)

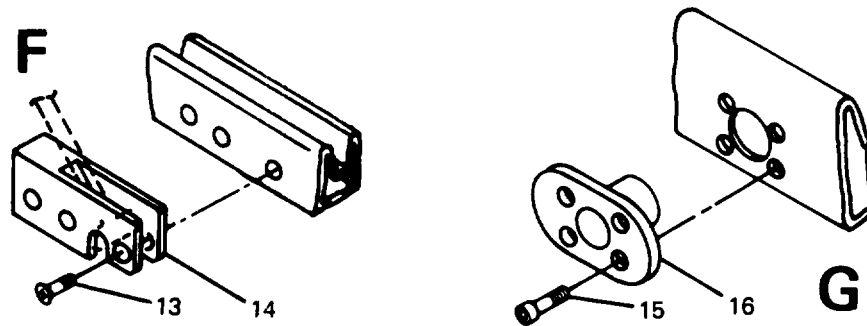

10. Drill out blind rivets (19) and remove shear plate (20). (Refer to paragraph 4-32)

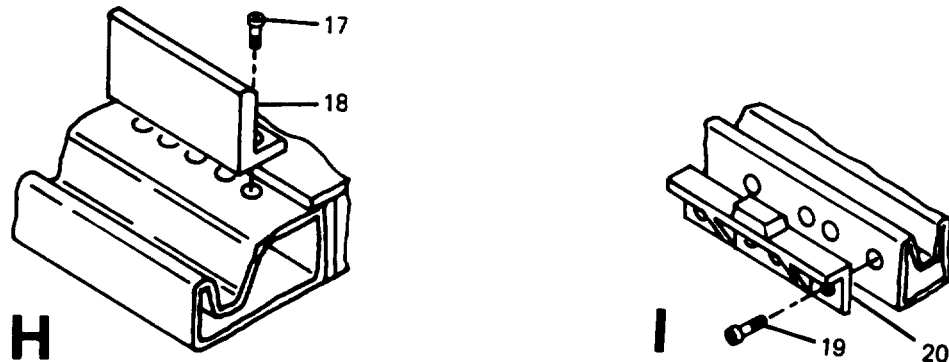

CLEANING, INSPECTION

1. Clean panel and component surfaces.
2. Inspect mounting surfaces for corrosion and damage.
3. Inspect for and replace if necessary:
 - a. Missing or damaged components
 - b. Corrosion or paint damage.

Repair

1. Panel skin damage. (Refer to paragraphs 4-31 through 4-42.)
2. Corrosion or paint damage. (Refer to paragraph 4-43)

4-23. (cont)

ASSEMBLY

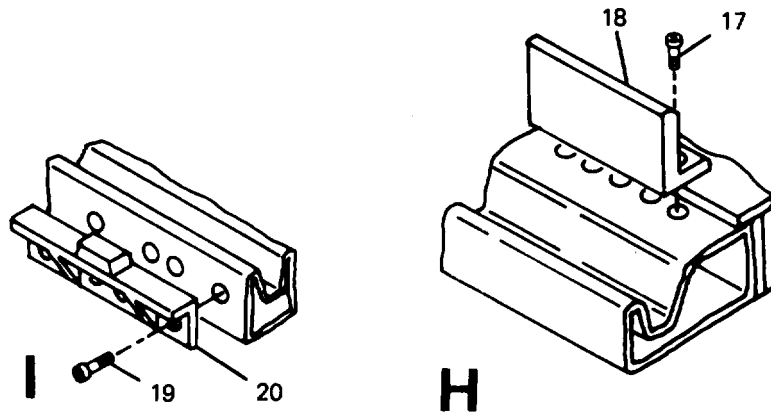

1. Position shear plate (20) and install rivets (19). (Refer paragraph 4-32)
2. Position stop angle (18) and install rivets (17). (Refer to para. 4-32)
3. Position brace cup (16) and install rivets (15). (Refer to paragraph 4-32)
4. Position bracket (14) and install screws (13).

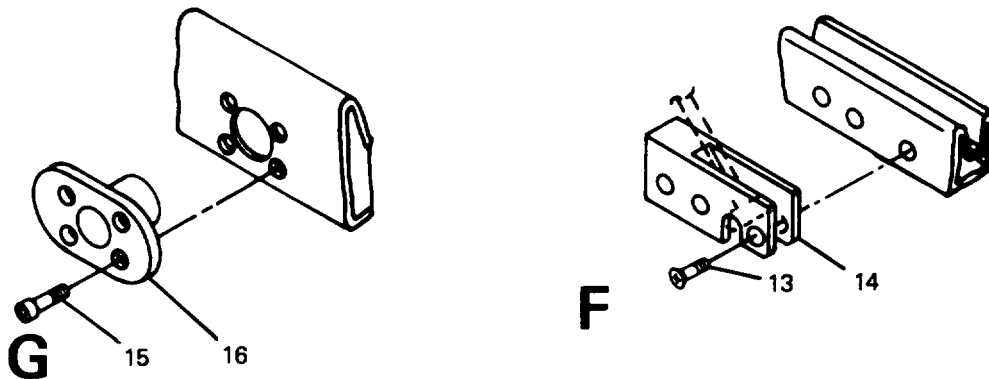

5. Position closeout seal (12) and install rivets (11). (Refer to paragraph 4-32)
6. Position grommets (10) and install rivets (9). (Refer to paragraph 4-32)

4-23. (cont)

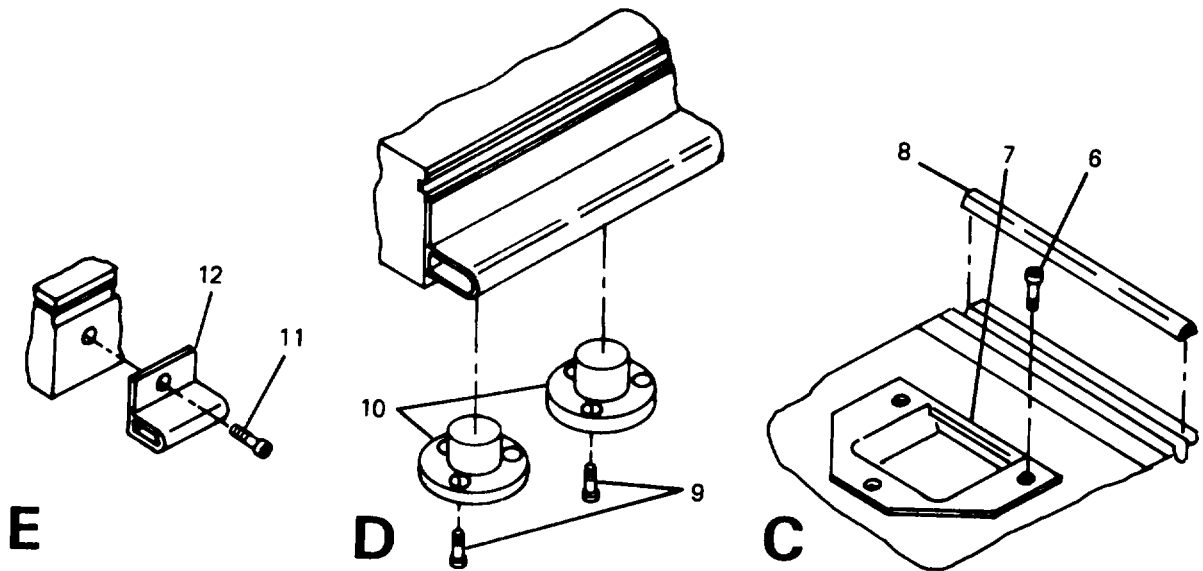

7. Install seal (8) with adhesive. (Refer to paragraph 4-40)
8. Position strike cup (7) and install rivets (6). (Refer to paragraph 4-32)

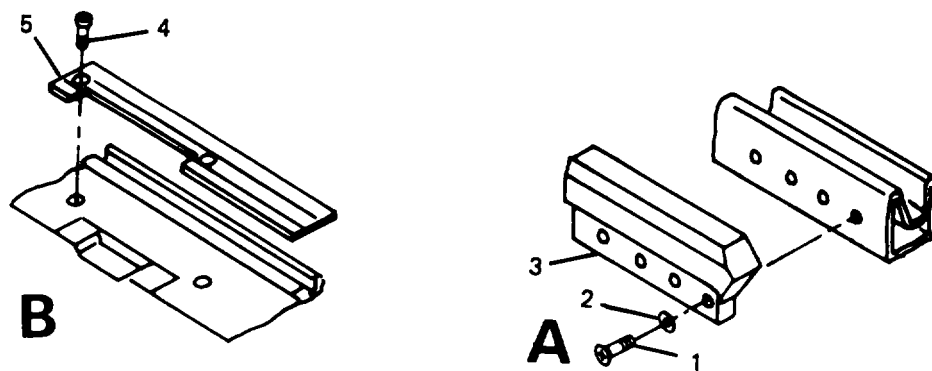

9. Coat threshold (5) and mounting surface with sealant.
10. Position threshold (5) and install rivets (4). (Refer to paragraph 4-32)
11. Position cam strike (3) and install washers (2) and screws (1).

4-23. (Cont)

INSTALLATION

1. position and support hinged floor to engage fixed floor hinge (4) and install two hinge pins (3).
2. Connect support cables to two cable guide brackets (2) and install screws (1).
3. Install hinged sidewall in accordance with paragraph 4-22.
4. Open stops on cable load balancers mounted inside fixed roof.

NOTE

Seal (5) is installed after floor is completely installed with shelter in closed configuration.

5. Install seal (5) between fixed floor (4) and hinged floor (6).

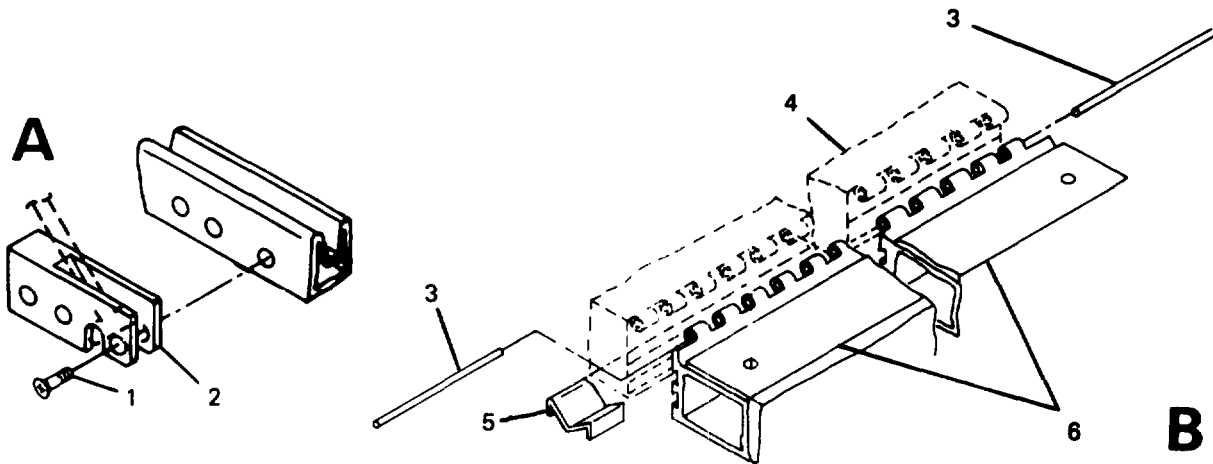

4-24. CONTAINER LIFT JACK ASSEMBLY SERVICE AND REPAIR

This task covers:

- a. Disassembly
- b. Cleaning, Inspection
- c. Repair
- d. Lubrication
- e. Assembly

INITIAL SETUP

Standard tools

General mechanics tool kit
Grease gun

Materials

Grease, Item 12, Appendix E

DISASSEMBLY

1. Remove nut (1), spring plunger (2), pin (3), and handle (4).
2. Remove pin (4) and separate handle (5) from support (6). Remove two O-rings (30) from handle (5).
3. Remove grease fitting (7).
4. Remove rivet (8) to remove lanyard (9) and safety pin (10).

NOTE

Do not remove lanyard unless pins or cables are damaged.

5. Remove screws (11), lockwashers (12), and spring tension clip (13).
6. Remove cotter pin (14), washer (15), pin (16), and spacers (17) to remove base (18) from basic jack.
7. Remove inside tube (19) and jack screw (20) from outside tube (21).
8. Remove bearing (22).
9. Drive pin (23) out through access hole and remove jack screw (20) from inside tube (19).
10. Remove screws (24), retainer (25), and rotating insert (26).
11. Remove screws (27), lockwashers (28), and handle (29). Remove O-rings (30).

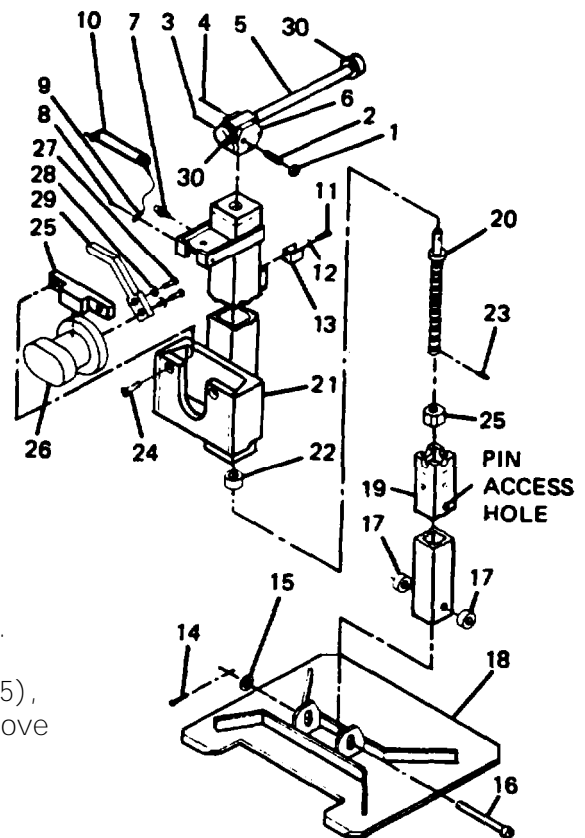

4-24. (cont)

CLEANING, INSPECTION

1. Clean jack assembly and component surfaces.
2. Inspect mounting surfaces for corrosion and damage.
3. Inspect for and replace if necessary:
 - a. Missing or damaged components
 - b. Corrosion or paint damage.

REPAIR

Corrosion or paint damage. (Refer to para. 4-43)

LUBRICATION

Lubricate jack assembly with grease.

ASSEMBLY

1. Position handle (29) on rotating insert (26) and install lockwashers (28) and screws (27). Install O-rings (30).
2. Position rotating insert (26) in outside tube (21) and secure retainer (25) with screws (24).
3. Install jack screw (20) in inside tube (19).
4. Align hole in jack screw (20) with access hole in inside tube (19) and install pin (23).
5. Pack bearing (22) with grease and place on jack screw (20).
6. Install inside tube (19) in outside tube (21).

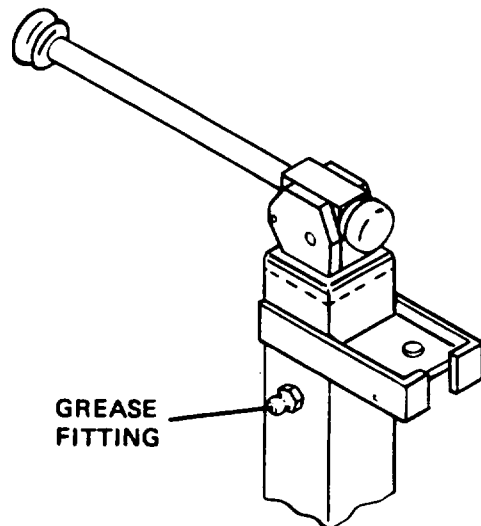
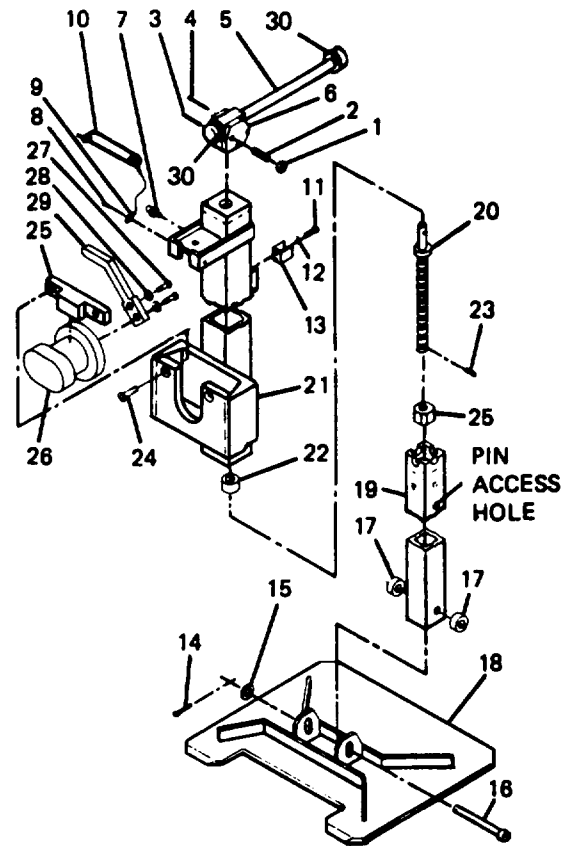

4-24. (cont)

7. Position handle (5) in support (6) and on jack screw (19) with holes in handle yoke and jack screw aligned. Install pins (3 and 4).
8. Install spring plunger (2) in handle yoke and secure with nut (1). Adjust nut to control handle movement.
9. Position basic jack on base (18) with spacers (17) and secure with pin (16), washer (15), and new cotter pin (14).
10. Install grease fitting (7) and lubricate jack with grease.

4-25. PERSONNEL DOOR END ENDWALL PANEL REPLACEMENT AND REPAIR

This task covers:

- | | |
|-------------------------|-----------------|
| a. Removal | d. Repair |
| b. Disassembly | e. Assembly |
| c. Cleaning, Inspection | f. Installation |

INITIAL SETUP

Special Tools

Hand blind riveter, Appendix B, Item 2

Personnel - 4

1 Electrician

Materials

Adhesive, Item 2, Appendix E

Standard tools

General mechanics tool kit

REMOVAL

Personnel Door End Endwall Panel

1. Set main circuit breaker to OFF position.
2. Disconnect service entry power at power entry panel and remove components. (Refer to paragraph 5-3)
3. Remove door activated blackout switch and associated wiring. (Refer to paragraph 4-15)
4. Remove area light assembly. (Refer to paragraph 3-4)
5. Remove hinged endwalls adjacent to personnel door end panel endwall in accordance with paragraph 4-21.

4-25. (cont)

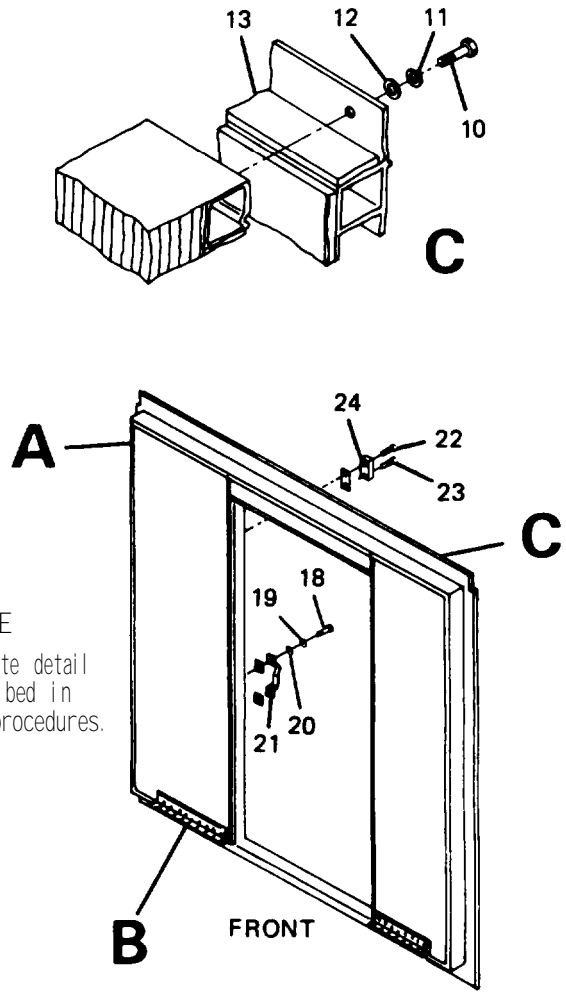
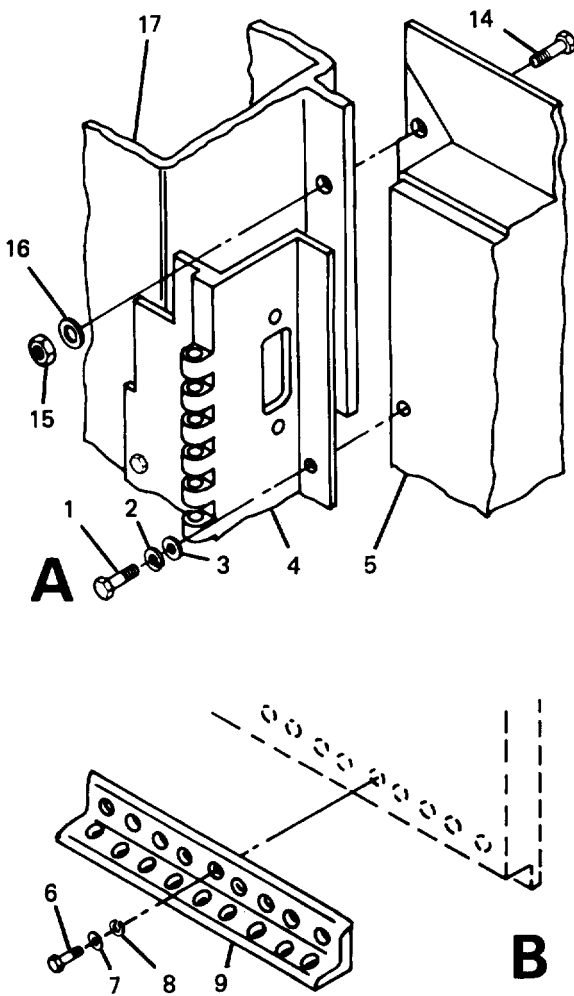

NOTE
 Letters locate detail views described in following procedures.

6. Remove screws (1), lockwashers (2), and washers (3) securing hinged endwall hinge (4) to fixed endwall (5) and corner post.
7. Remove screws (6), lockwashers (7), and washers (8) securing reinforcement angles (9) to fixed endwall.
8. Remove bolts (10), lockwashers (1) and washers (12) securing fixed endwall (13) to fixed roof and floor.
9. Remove bolts (14), nuts (15), and washers (16) securing fixed endwall (5) to corner posts (17).
10. Remove screws (18), lockwashers (19), and washers (20) and remove ice break (21).
11. Remove screws (22 and 23) and remove keepers (24).

4-25. (cont)

12. Support fixed endwall and remove by using a putty knife (or similar tool) to break bond between endwall and fixed roof, fixed floor, and corner posts.

Level Assembly

13. Drill out six rivets (25) and remove each of two level assemblies (26). (Refer to paragraph 4-32)

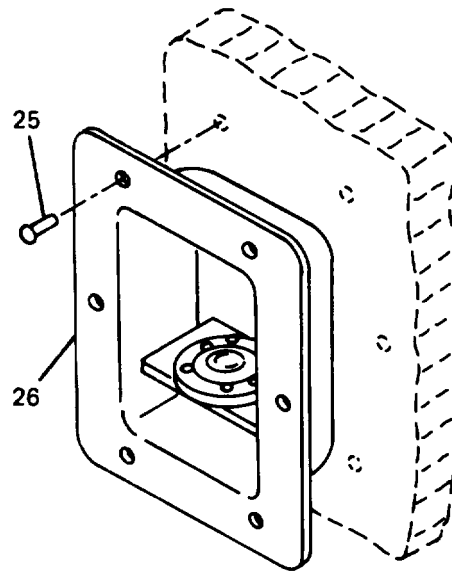

Folding Step

14. Remove two screws (27) and lockwashers (28) and remove each of five folding steps (29).

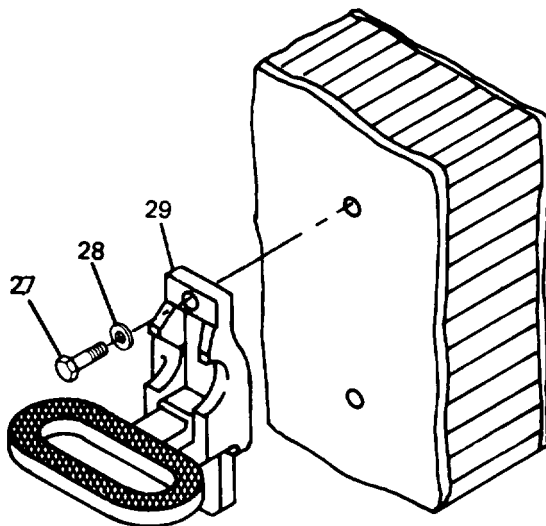

4-25. (cont)

DISASSEMBLY

Personnel Door End Endwall Panel

NOTE
Letters locate detail
views described in
following procedures.

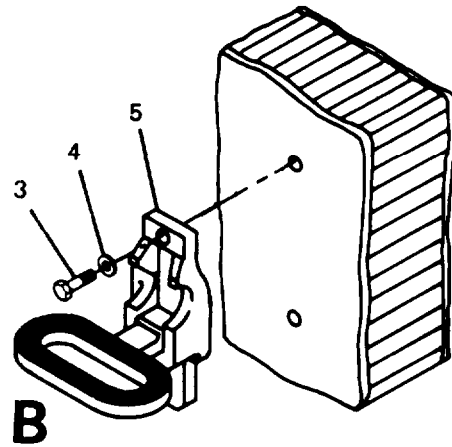
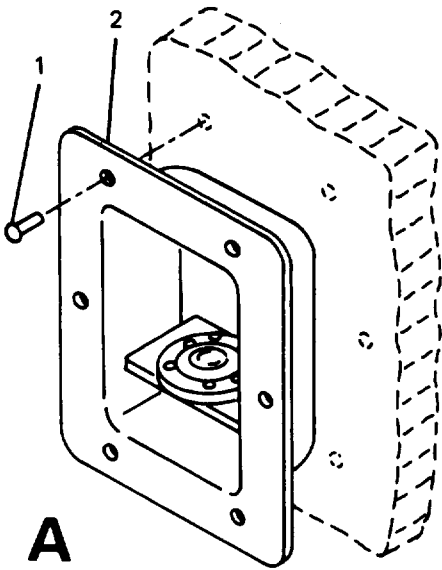
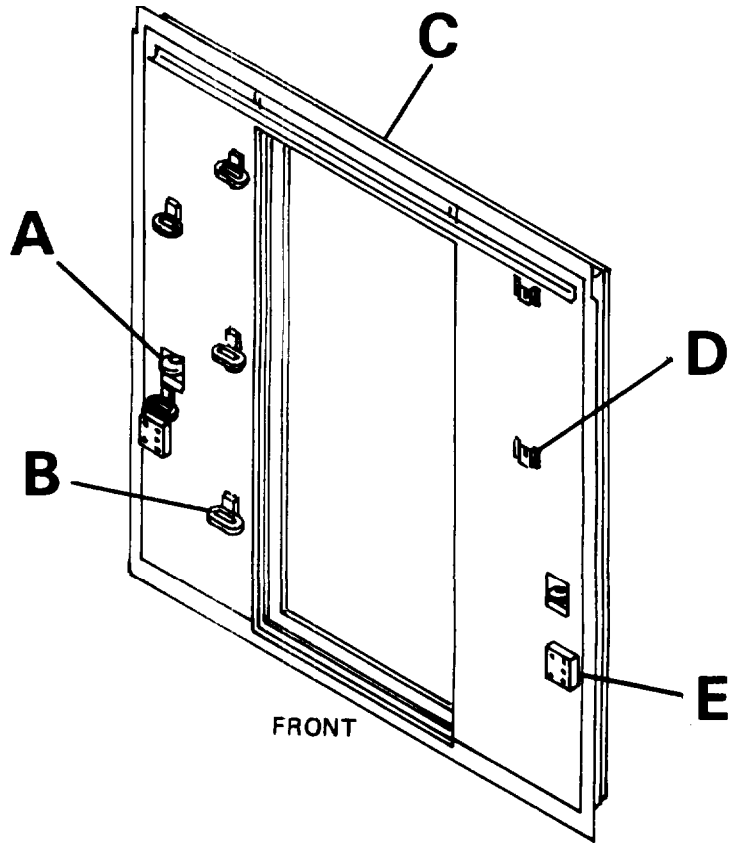

1. Drill out rivets (1) and remove level (2). (Refer to paragraph 4-32)
2. Remove screws (3) and lockwashers (4) and remove folding step (5).

4-25. (cont)

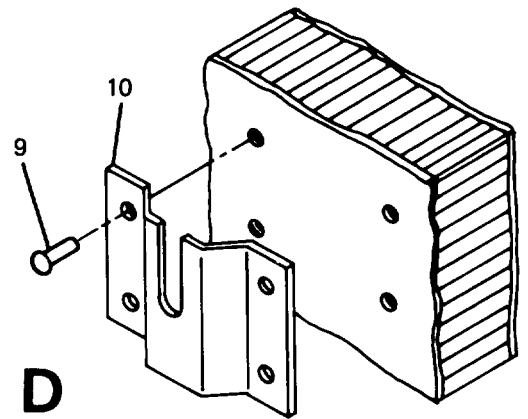
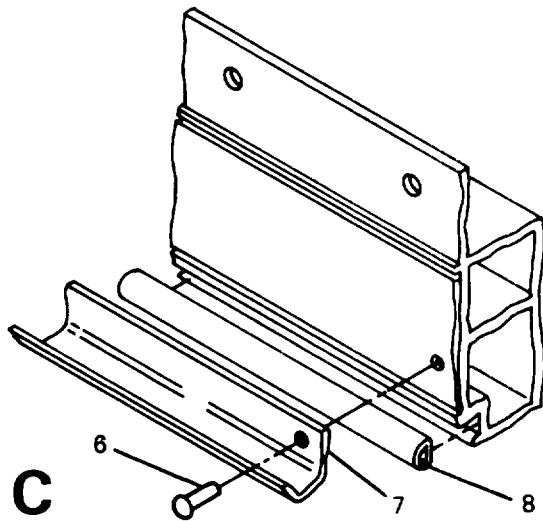

3. Drill out rivets (6) and remove drip strip (7). (Refer to paragraph 4-24)
4. Strip seal (8) away from door opening.
5. Drill out rivets (9) and remove light bracket (10). (Refer to paragraph 4-32)
6. Remove screws (11) and lockwashers (12) and remove upper mobilizer fitting (13).

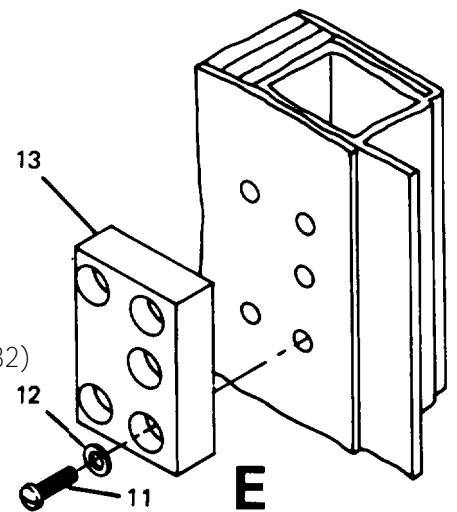

Level Assembly

7. Remove screws (14), lockwashers (15), and setscrews (16) and remove level indicator (17) from level bracket (19).
8. Drill out rivets (18) and remove level bracket (19) from level pan (20). (Refer to paragraph 4-32)

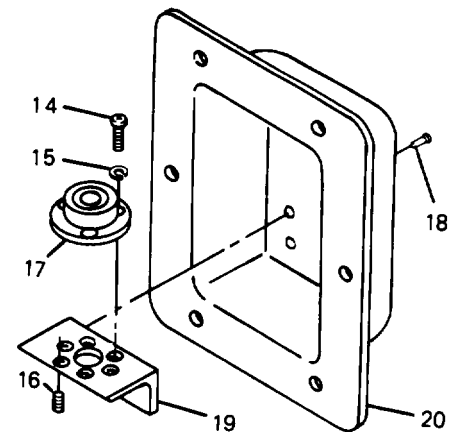

CLEANING, INSPECTION

1. Clean panel and component surfaces.
2. Inspect mounting surfaces for corrosion and damage.
3. Inspect for and replace if necessary:
 - a. Missing or damaged components
 - b. Corrosion or paint damage.

4-25. (cont)

REPAIR

Panel skin damage. (Refer to paragraphs 4-31 through 4-42.)

Correction or paint damage. (Refer to paragraph 4-43)

ASSEMBLY

Level Assembly

1. Secure level bracket (19) to level pan (20) by installing rivets (18). (Refer to paragraph 4-32)
2. Position level indicator (17) on level bracket and install set-screws (16), lockwashers (15), and screws (14).

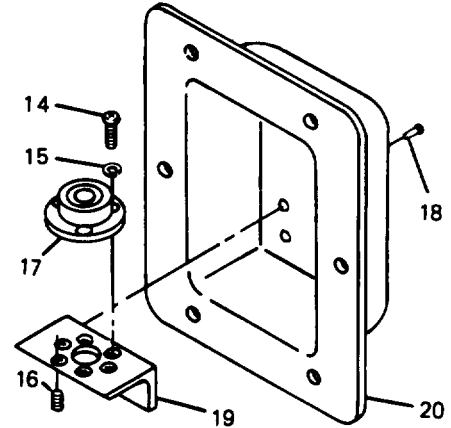

Personnel Door End Endwall Panel

3. Position mobilizer fitting (13) and install lockwashers (12) and screws (11).
4. Position light bracket (10) and install rivets (9). (Refer to paragraph 4-32)
5. Bond seal (8) in place with adhesive. (Refer to paragraph 4-40)

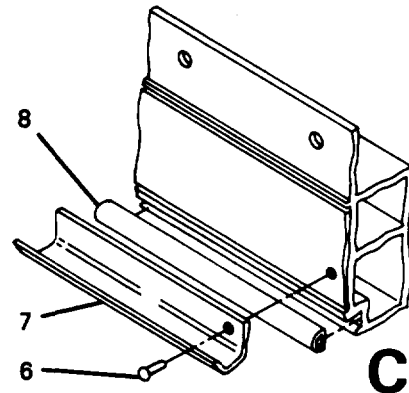
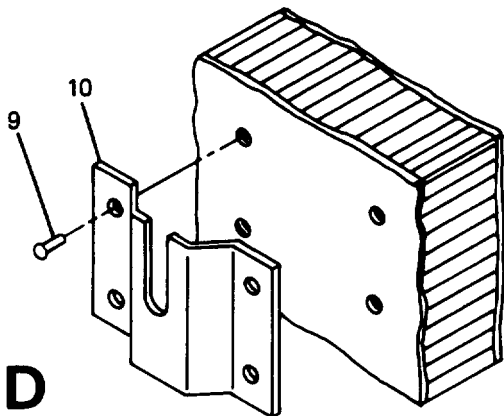
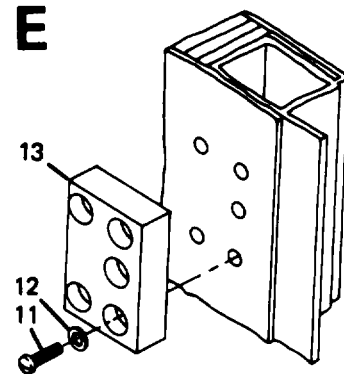

6. Position drip strip (7) and install rivets (6). (Refer to paragraph 4-32)

4-25. (cont)

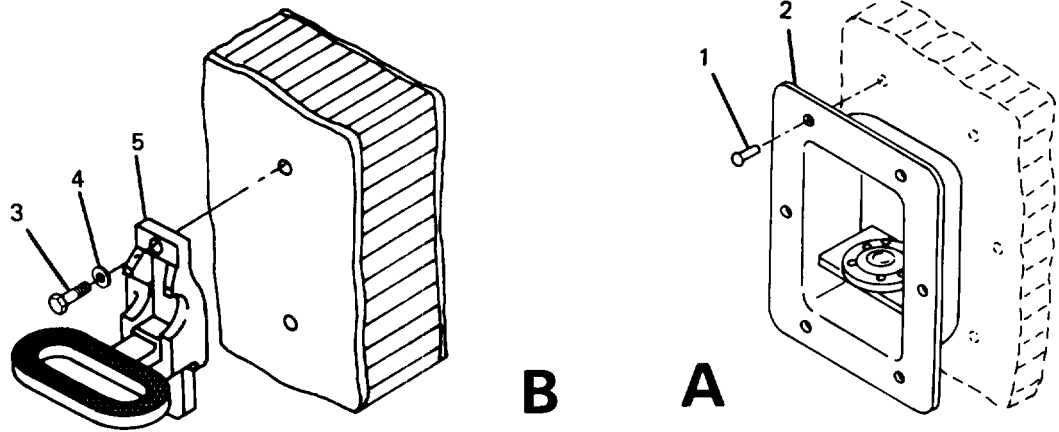

7. Position folding step (5) and install lockwashers (4) and screws (3).
8. Position level (2) and install rivets (1). (Refer to paragraph 4-32)

Folding Step

1. Position each of five folding steps (29) against panel and install two lockwashers (28) and screws (27).

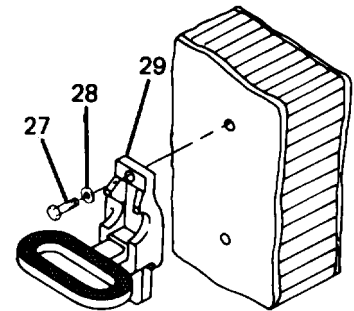

Level Assembly

2. Secure each of two level assemblies (26) by installing six rivets (25). (Refer to paragraph 4-32)

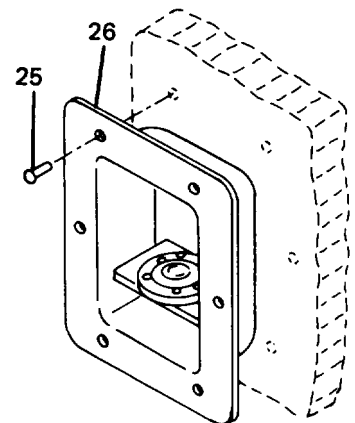

NOTE

Level assemblies must be calibrated after assembly of shelter is complete. Use a four foot level or other suitable tool and adjust three setscrews on level to calibrate.

4-25. (cont)

Personnel Door End Wall Panel

3. From outside shelter, position fixed endwall on fixed floor and push inward until endwall is against corner posts mating surfaces.
4. Align fixed endwall mounting holes with mounting holes and inserts in corner posts, fixed roof, reinforcement angles, and endwall hinge.

NOTE

Align mounting holes at fixed endwall corners and insert bolts. Check that remaining holes and inserts are aligned and free from obstructions.

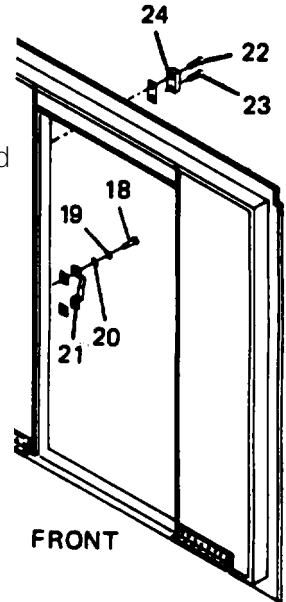

5. Install screws (22 and 23) securing keepers (24) to fixed endwall (5).
6. Install screws (18), lockwashers (19), and washers (20) securing ice break (21) to fixed endwall (5).
7. Install bolts (14), washers (16), and nuts (15) securing fixed endwall (5) to corner posts (17).

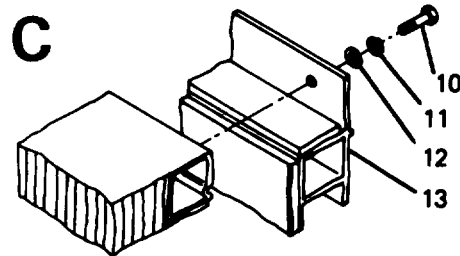
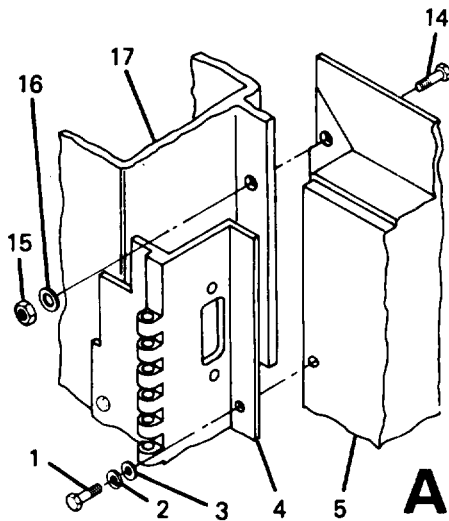

4-25. (cont)

8. Install washers (12), lockwashers (11), and bolts (10) securing fixed endwall (13) to fixed roof and floor.
9. Install washers (8), lockwashers (7), and screws (6) securing reinforcement angles (9) to fixed endwall.

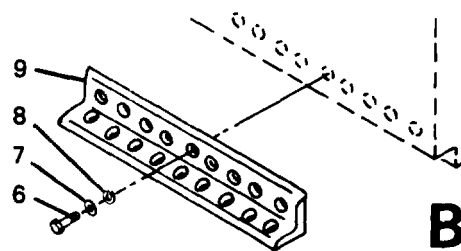

10. Install washers (3), lockwashers (2) and screws (1) securing endwall hinge (4) to fixed endwall (5) and corner post.
11. Install hinged endwalls in accordance with paragraph 4-21.
12. Install area light assembly. (Refer to paragraph 3-4)
13. Install door activated blackout switch and associated wiring. (Refer to paragraph 4-15)
14. Install power entry panel. (Refer to paragraph 5-3)
15. Connect services entry power and set main circuit breaker to ON position.

4-26. CARGO DOOR END ENDWALL PANEL REPLACEMENT AND REPAIR

This task covers:

- | | |
|-------------------------|-----------------|
| a. Removal | d. Repair |
| b. Disassembly | e. Assembly |
| c. Cleaning, Inspection | f. Installation |

INITIAL SETUP

Special Tools

Hand blind riveter, Appendix B, Item 2

Standard Tools

General mechanics tool kit

Materials

Adhesive, Item 2, Appendix E

Personnel - 4

4-26. (cont)

REMOVAL

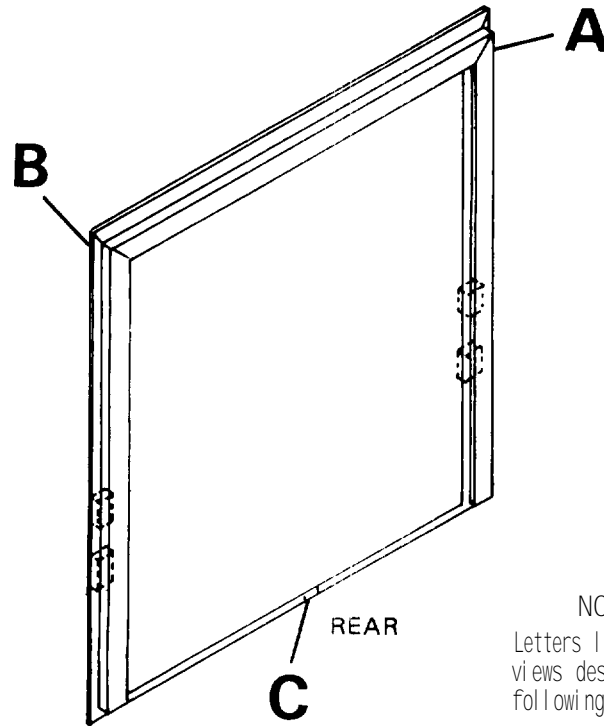

NOTE
Letters locate detail
views described in
following procedures.

1. Remove cargo doors in accordance with paragraphs 4-17 and 4-18.
2. Remove hinged endwalls adjacent fixed cargo endwall in accordance with paragraph 4-21.
3. Remove screws (1), lockwashers (2), and washers (3) securing hinged endwall hinge (4) to fixed endwall and corner post.
4. Remove bolts (5), nuts (6) and washers (7) securing fixed endwall (13) to corner posts (8).
5. Remove bolts (9), lockwashers (10), and washers (11) securing drip cap (12) and fixed endwall (13) to fixed roof.

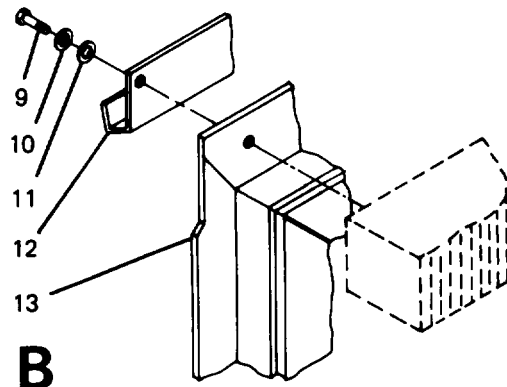
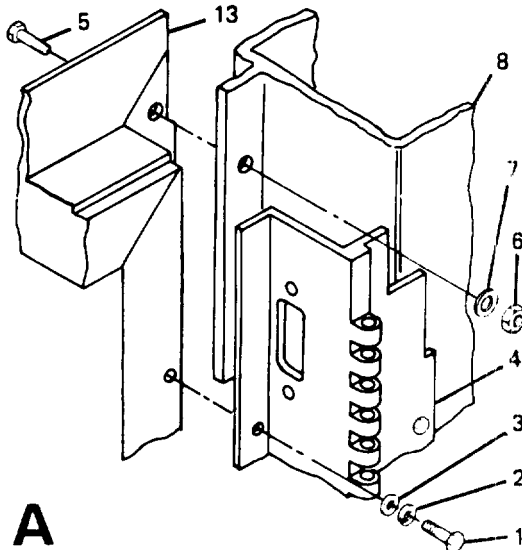

4-26. (cont)

6. Remove eight screws (14), eight screws (15), shear plate (16) and shims (17 and 18).
7. Remove bolts (9), lockwashers (10), and washers (11) securing fixed endwall (13) to fixed floor.
8. Support fixed endwall, cut through adhesive sealant, and remove by using a putty knife (or similar tool) to break bond between endwall and fixed roof, fixed floor, and corner posts.

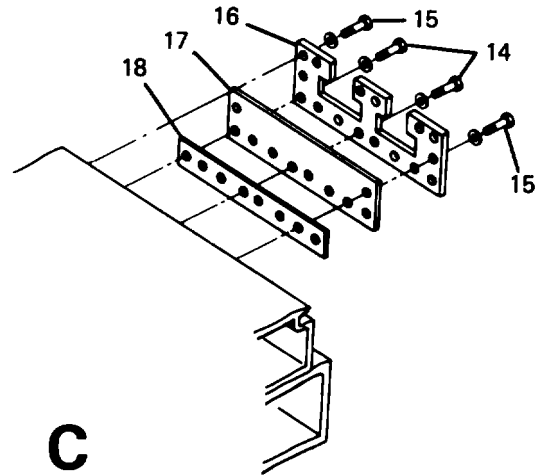

DI SASSEMBLY

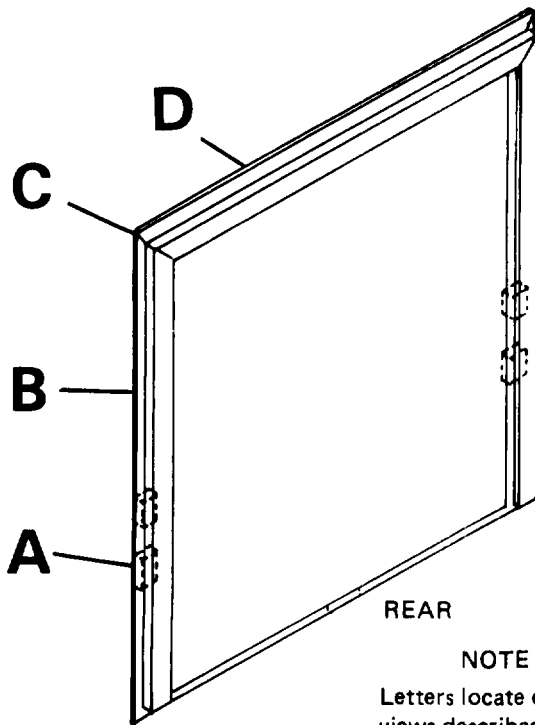

REAR

NOTE

Letters locate detail views described in following procedures.

1. Remove screws (1) and lockwashers (2) and remove upper mobilizer fittings (3).
2. Drill out rivets (4) and remove level pan (5). (Refer to paragraph 4-32)

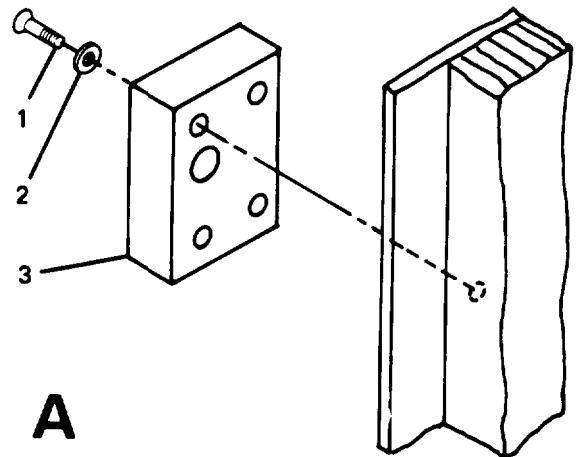

A

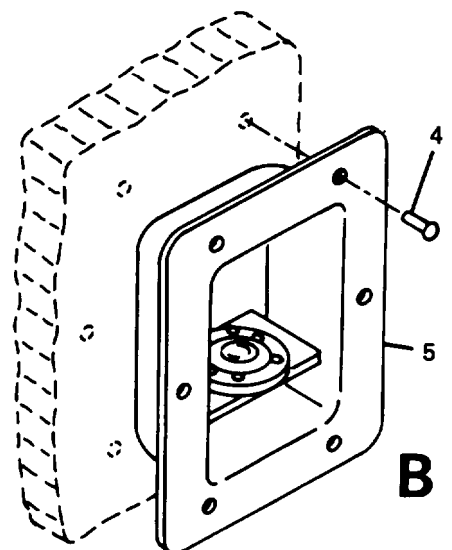

B

4-26. (cont)

4. Remove bolts (6), lockwashers (7), drip cap (8), and washers (9).
5. Strip seal (10) away from opening.

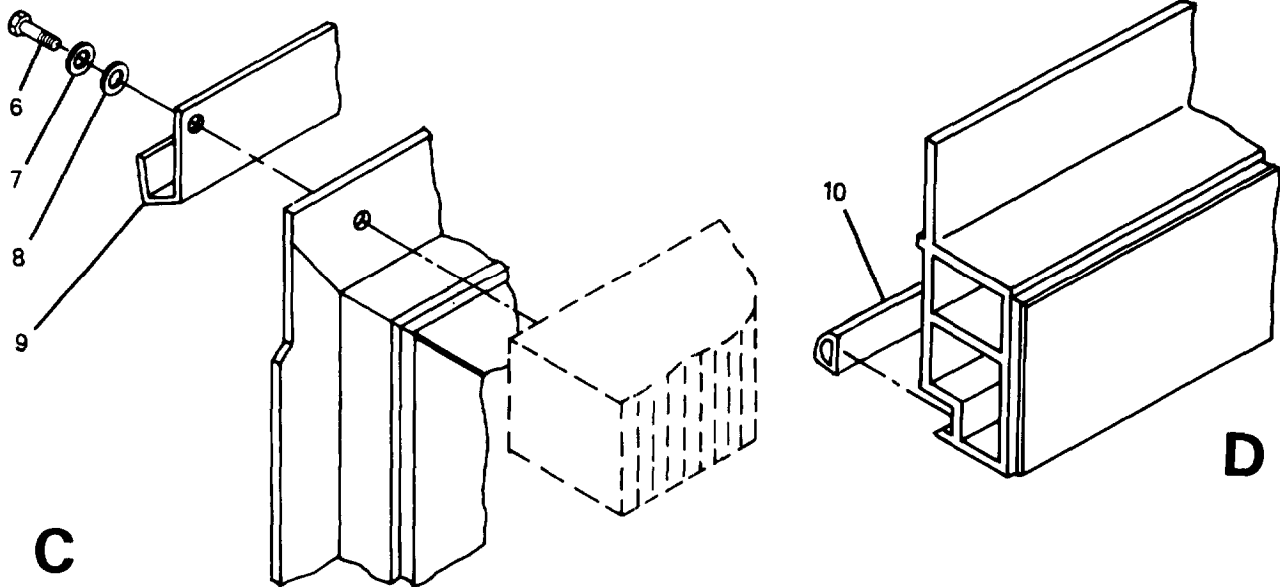

CLEANING, INSPECTION

1. Clean panel and component surfaces.
2. Inspect mounting surfaces for corrosion and damage.
3. Inspect for and replace if necessary:
 - a. Missing or damaged components
 - b. Corrosion or paint damage.

REPAIR

1. Panel skin damage. (Refer to paragraphs 4-31 through 4-42.)
2. Corrosion or paint damage. (Refer to paragraph 4-43)

ASSEMBLY

1. When assembling endwall panel to roof, position drip cap (8) and install washers (9), lockwashers (7) and bolts (6).
2. position upper mobilizer fitting (3) and install lockwashers (2) and screws (1).
3. Position level (5) and install rivets (4). (Refer to paragraph 4-32)

4-26. (cont)

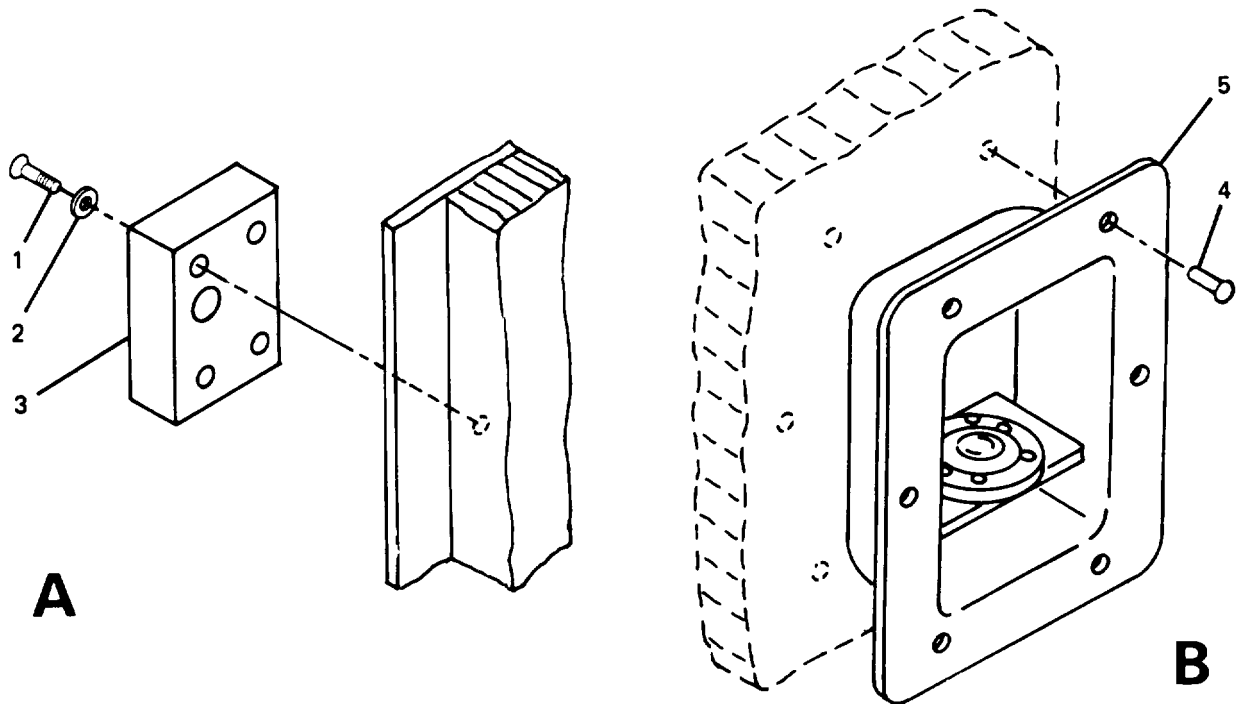

4. Bond seal (10) in place with adhesive. (Refer to paragraph 4-40)

INSTALLATION

1. Apply adhesive before positioning endwall panel.
2. From outside shelter, position fixed endwall on fixed floor and push inward until endwall is against corner posts mating surfaces.
3. Align fixed endwall mounting holes with mounting holes and inserts in corner posts, fixed roof, fixed floor, and endwall hinge.

NOTE

Align mounting holes at fixed endwall corners and install bolts. Check that remaining holes and inserts are aligned and free from obstructions.

4-26. (cont)

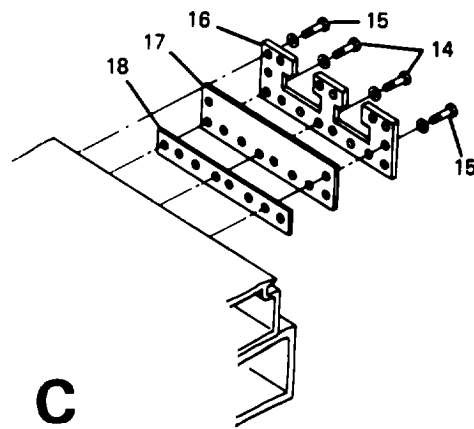
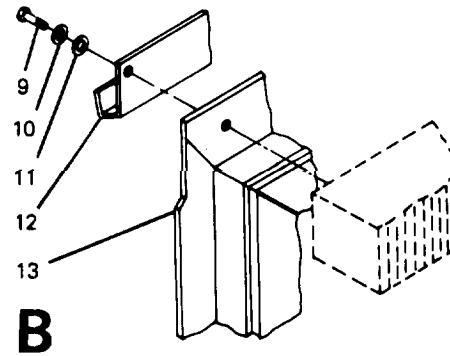
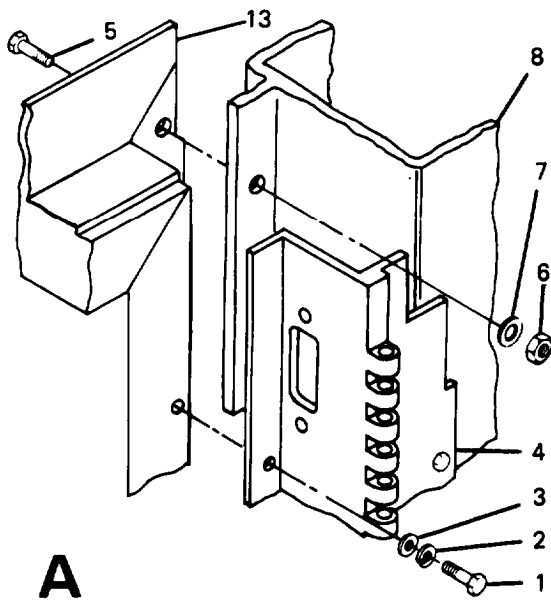

4. Install bolts (5), washers (7), and nuts (6) securing fixed endwall to corner posts (8).
5. Install washers (11), drip cap (12), lockwashers (10), and bolts (9) securing fixed endwall (13) to fixed roof.
6. Install washers (11), lockwashers (10), and bolts (9) securing fixed endwall (13) to fixed floor.
7. Install washers (3), lockwashers (2), and screws (1) securing hinged endwall hinge (4) to fixed endwall (13) and corner post.
8. Position shims (17 and 18) and shear plate (16) against endwall panel and floor and secure with eight screws (15) and eight screws (14).
9. Install cargo doors in accordance with paragraphs 4-17 and 4-18.
10. Install hinged endwalls in accordance with paragraph 4-21.
11. Calibrate level after shelter is assembled using four-foot level and three setscrews to properly calibrate.

4-27. ROOF PANEL ASSEMBLY REPAIR

This task covers:

- | | |
|-------------------------|-----------------|
| a. Removal | d. Repair |
| b. Disassembly | e. Assembly |
| c. Cleaning, Inspection | f. Installation |
-

INITIAL SETUP

Special tools

Hand blind riveter, Appendix B, Item 2

Standard tools

General mechanics tool kit

Personnel - 4

Materials

Adhesive, Item 2, Appendix E

Adhesive, Item 3, Appendix E

REMOVAL

Load Balancer and Cable Assembly

NOTE
Letters locate detail views described in following procedures

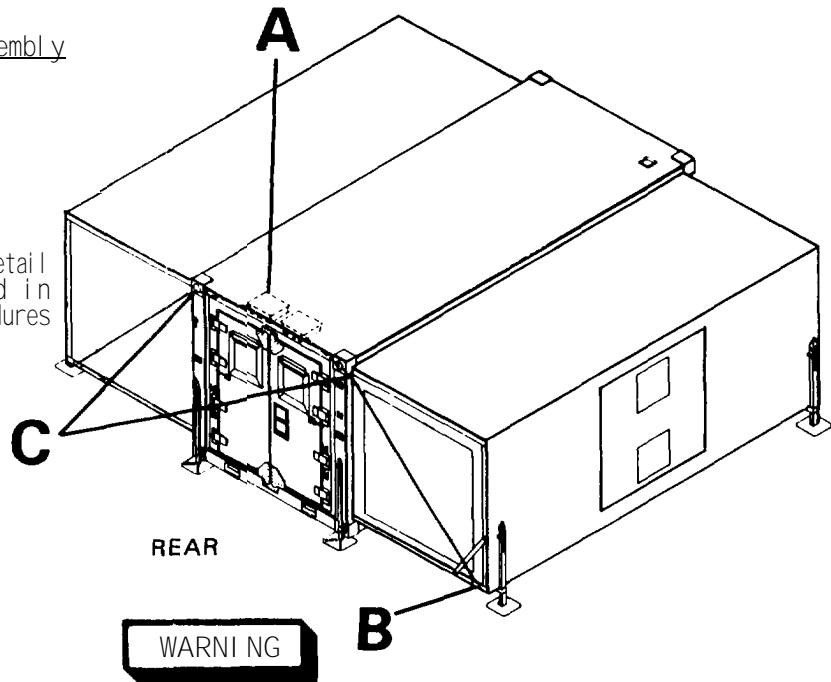

Prior to removing load balancer from fixed roof, the hinged floor must be in stowed position with stop plate in down position to remove tension from support cable. The support cable bracket on hinged floor must then be removed to permit disconnecting support cable from hinged floor. Secure hinged floor to prevent accidental release.

1. Lower hinged sidewall to hinged floor in accordance with paragraph 2-16.

4-27. (cont)

2. Lift stop plates (1) from support cables (2) on both load balancers (3) mounted on fixed roof.
3. Lift hinged floor until almost closed then lower stop plate (1) to remove weight from support cables (2) and secure hinged floor in this position.
4. Remove screw (4) from cable guide bracket (5) and disengage support cable (2).

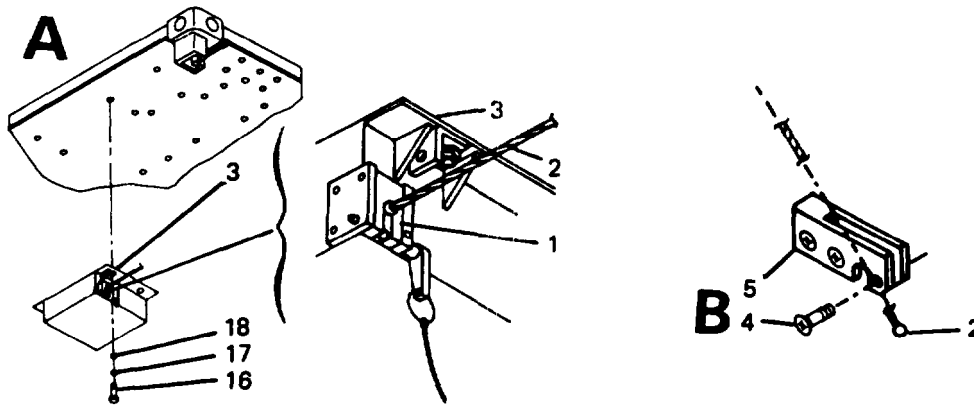

WARNING

Do not attempt to disassemble or repair load balancer. This item is a spring powered mechanism and injury or death to personnel may result if opened. Never completely release all the tension from the reel assembly or the cable wrapped around the drum will become tangled.

5. Return floor to stowed position.
6. Remove screws (6) securing roller assembly (7) to corner post (8).
7. Remove screws (9), lockwashers (10), and washers (11) securing roller assembly (12), plate (13), and seal (14) to endwall hinge (15).
8. Support load balancer (3) and remove screws (16), lockwashers (17), and washers (18).

4-27. (cont)

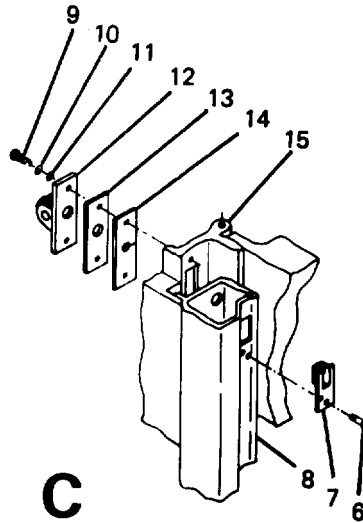

9. Lower load balancer from fixed roof.
10. Pull support cable (2) through corner post (8) and remove roller assemblies (7 and 12), plate (13), and seals (14) from support cable.

Stowage Brackets

11. Remove screws (19), lockwashers (20), and washers (21) and remove stowage brackets (22, 23, and 24).

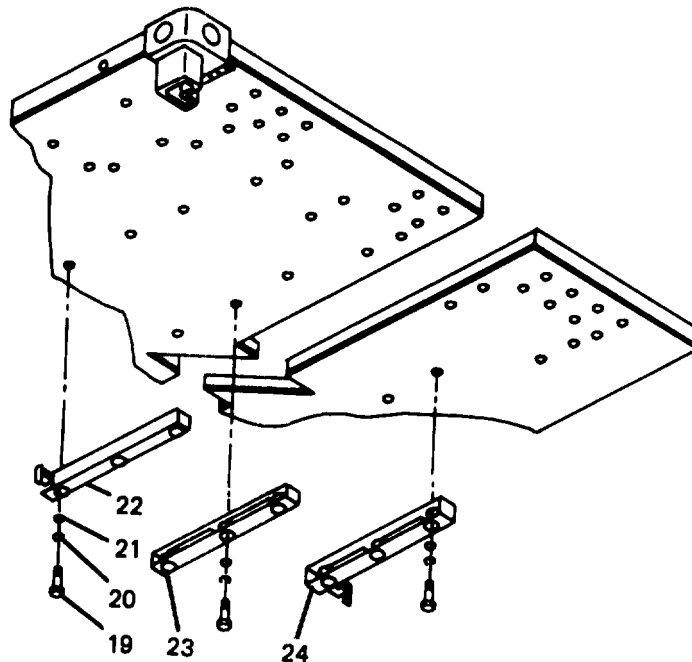

4-27. (cont)

Solar Bar Assembly

12. Remove screws (25), lockwashers (26), and washers (27) and remove pillow blocks (28).

NOTE

If hinged roof or hinge pins are removed from fixed roof hinges, solar bar assembly can be removed without removing push rod assemblies (33).

13. Remove cotter pins (29), washers (30), and pins (31) and remove solar bar assembly (32) from push rod assemblies (33).

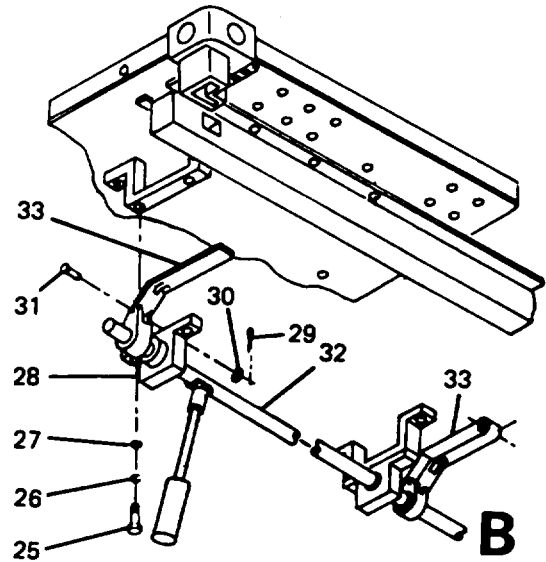

DISASSEMBLY

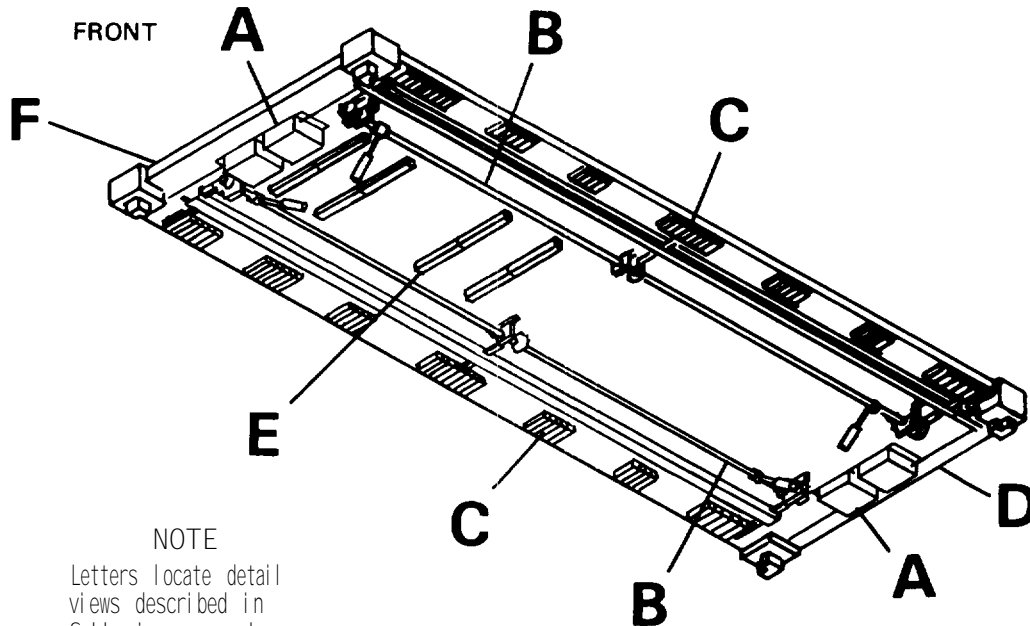

NOTE
Letters locate detail views described in following procedure.

4-27. (cont)

1. Remove screws (1), lockwashers (2), and washers (3) and separate pillow blocks (4) from hanger brackets (5)

NOTE

If hinged roof or hinge pins are removed from fixed roof hinges, solar bar assembly can be removed with rods.

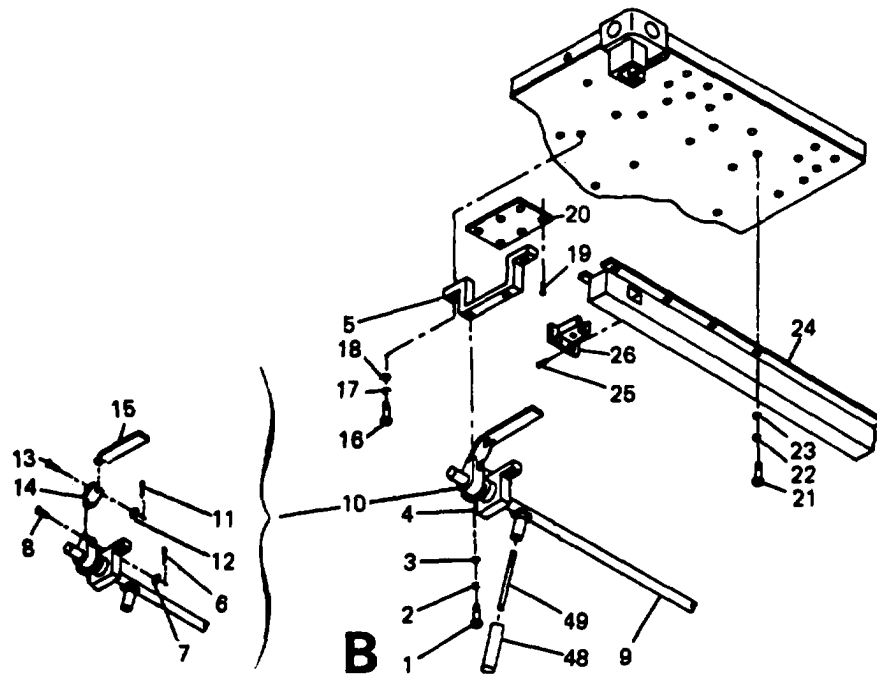

2. Remove cotter pins (6), washers (7), and pins (8) and remove solar bar (9) from push rod assemblies (10).
3. Remove cotter pins (11), washers (12), and pins (13) and separate push rods (14 and 15).
4. Remove screws (16), lockwashers (17), and washers (18) and remove hanger bracket (5).
5. Drill out rivets (19) and remove scuff plate (20). (Refer to para. 4-32)
6. Remove bolts (21), lockwashers (22), and washers (23) and remove fixed roof beam (24).
7. Drill out rivets (25) and remove push rod guide (26). (Refer to paragraph 4-32)
8. Remove handle grip (48) and handle (49) from solar bar. (14).

4-27. (cont)

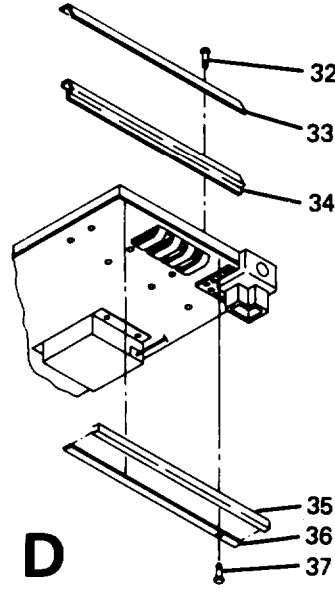
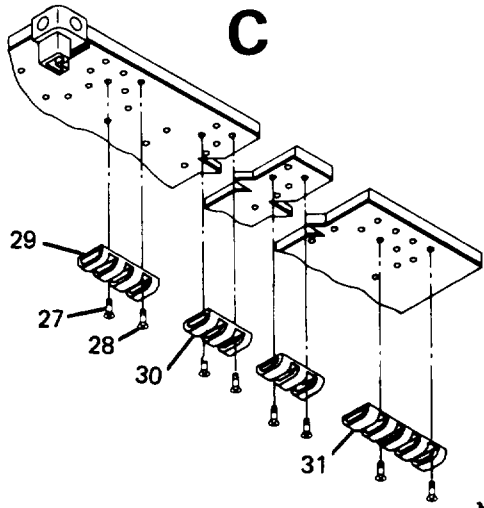

NOTE

Hinged roofs or hinge pins need to be removed to remove fixed roof hinges and seals.

9. Remove screws (27 and 28) and remove hinges (29, 30, and 31).
10. Drill out rivets (32 and 37) and remove seal cap (33), retainer strip (36) and seals (34 and 35). (Refer to paragraph 4-32)
11. Remove screws (38), lockwashers (39), and washers (40) and remove stowage brackets (41, 42, 43).
12. Remove screws (44), lockwashers (45), and washers (46) and remove handle (47).
13. Remove rivets (50) and removable light brackets (51).
14. Remove pins (52), washers (53), springs (54), handles (55), rivets (56), and plunger housing (57).

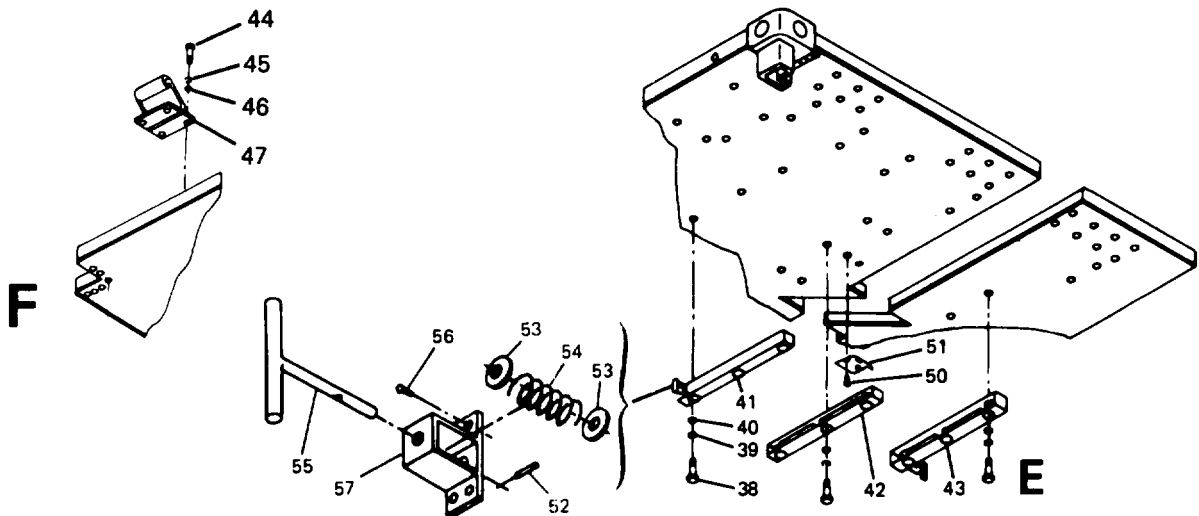

4-27. (cont)

CLEANING, INSPECTION

1. Clean panel and component surfaces.
2. Inspect mounting surfaces for corrosion and damage.
3. Inspect for and replace if necessary:
 - a. Missing or damaged components
 - b. Corrosion or paint damage.

REPAIR

1. Panel skin damage (Refer to paragraphs 4-31 through 4-42.)
2. Corrosion or paint damage. (Refer to paragraph 4-43)

ASSEMBLY

1. Position stowage brackets (41, 42, and 43) and install washers (40), lockwashers (39) and screws (38).
2. Install plunger housing (57), rivets (56), handles (55), springs (54), washers (53), and pins (52).
3. Install removable light brackets (51) and rivets (50).

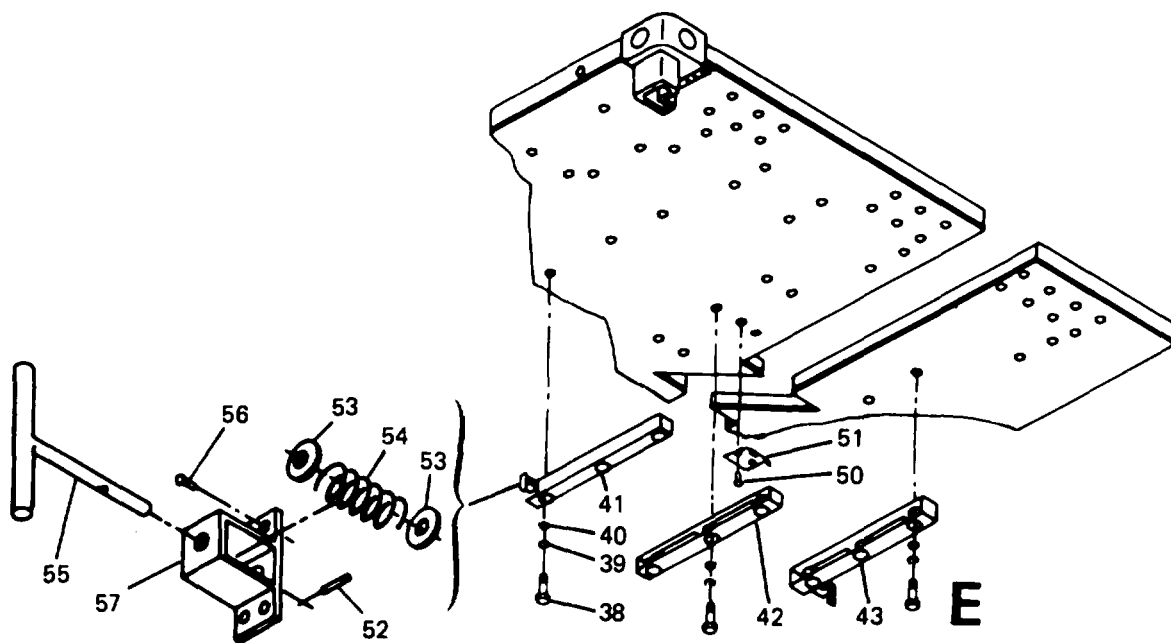

4-27. (cont)

4. Apply adhesive to seals (34 and 35) and mating surface. (Refer to paragraph 4-40)
5. Position retainer strip (36) and seal cap (33) and install rivets (32 and 37). (Refer to paragraph 4-32)
6. Position hinges (29, 30, and 31) and install screws (27 and 28).
7. Position rod guide (26) and install rivets (25). Refer to paragraph 4-32)

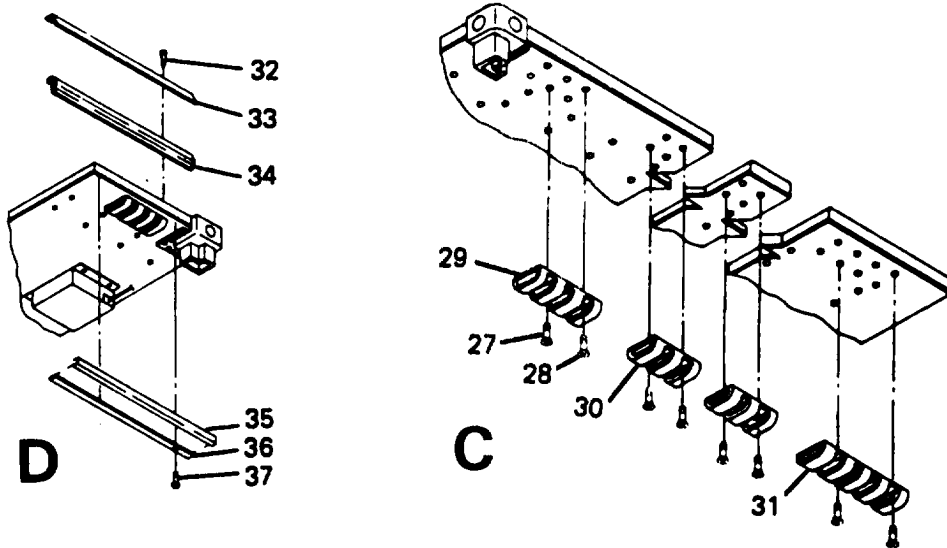

8. Position roof beam (24) and install washers (23), lockwashers (22), and bolts (21).
9. Position scuff plate (20) and install rivets (19). (Refer to para. 4-32)
10. Position hanger brackets (5) and install washers (18), lockwashers (17), and screws (16).
11. Assemble push rods (14 and 15) with pins (13), washers (12), and cotter pins (11).
12. Position and support solar bar (9) with push rods inserted in rod guides (26).
- 13* Install pins (8), washers (7), and cotter pins (6).
14. Position pillow blocks (4) on hanger brackets (5) and install washers (3), lockwashers (2), and screws (1).
- 15_o Position handle (47) on top of fixed roof and install washers (46), lockwashers (45), and screws (44).

4-27. (cont)

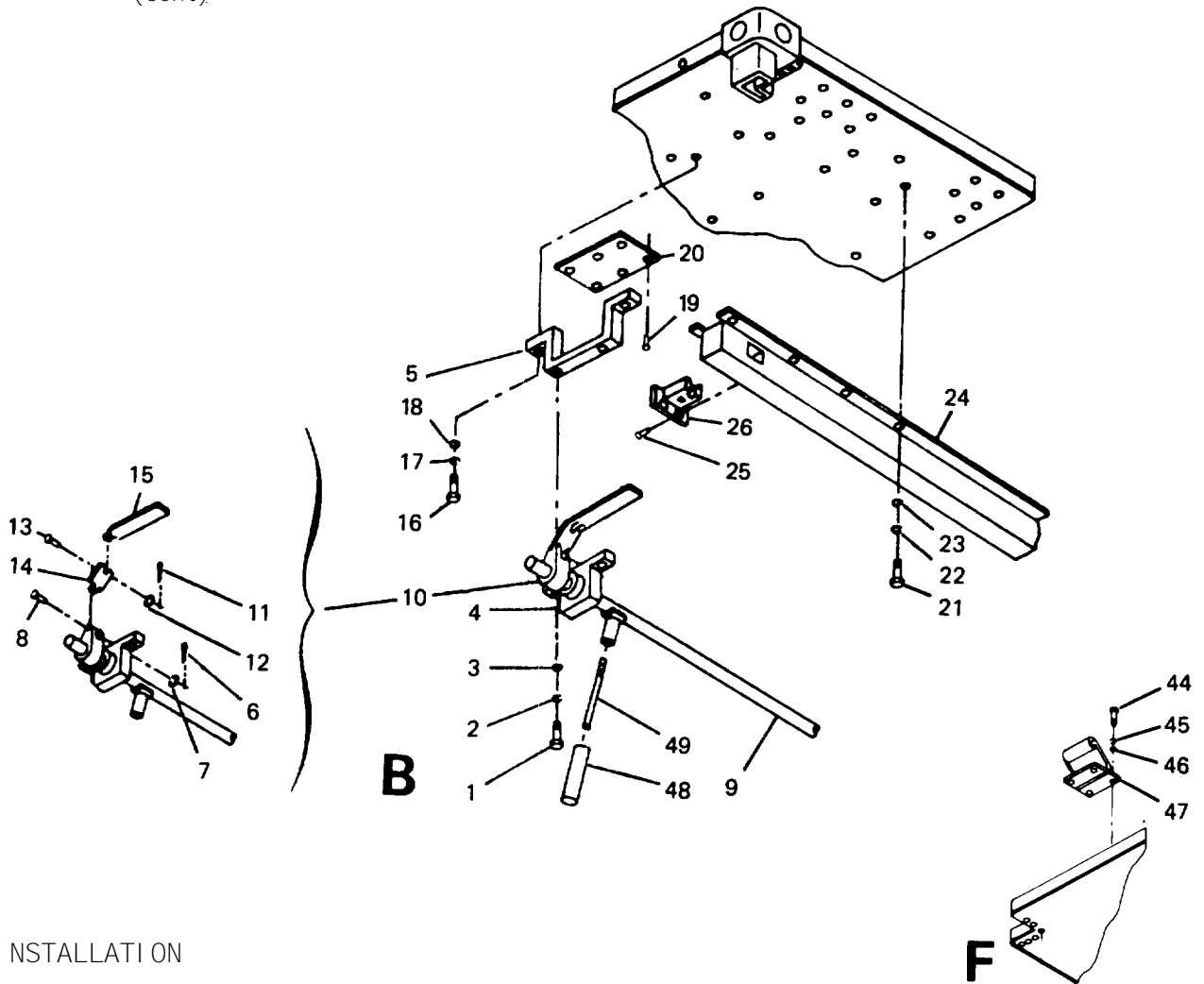

INSTALLATION

Solar Bar Assembly

1. Position solar bar assembly (32) with push rods inserted in rod guides and support solar bar.
2. Install pins (31), washers (30), and cotter pins (29).
3. Position pillow blocks (28) and install washers (27), lockwashers (26), and screws (25).

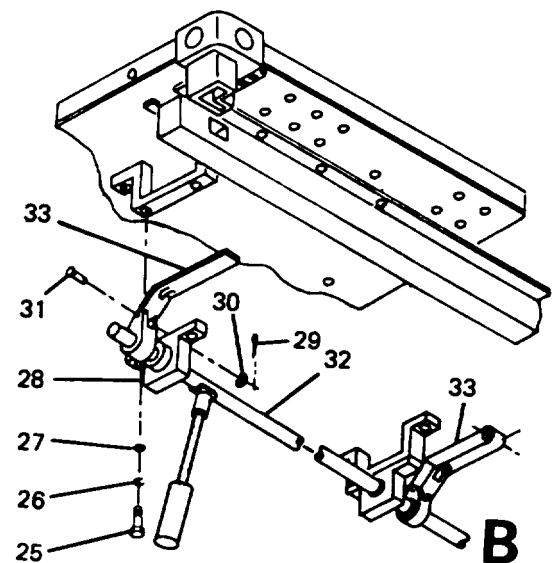

4-27. (cont)

Stowage Brackets

4. Position stowage brackets (22, 23, and 24) and install washers (21), lockwashers (20), and screws (19).

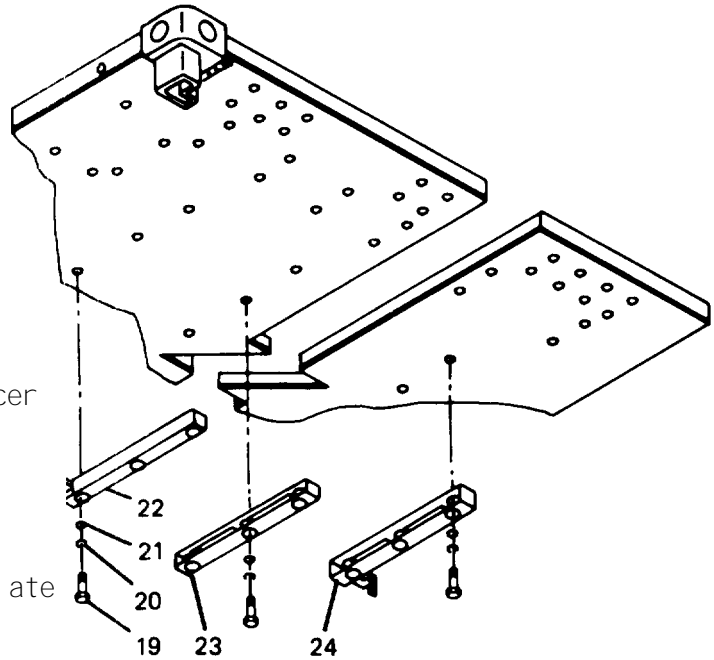

Load Balancer and Cable Assembly

1. Position and support load balancer (3) on fixed roof and install washers (18), lockwashers (17), and screws (16).
2. Insert end of support cable (2) through roller assembly (12), plate (13), seal (14), and then pull through endwall hinge (15) and corner post (8).
3. Position seal (14), plate (13), and roller assembly (12) on endwall hinge (15) and install washers (11), lockwashers (10) and screws (9).
4. Position roller assembly (7) against corner post (8) and support cable (2), and install screws (6).
5. Engage support cable (2) in cable guide bracket (5) and install screw (4).
6. Open stop plates (1) on both load balancers (3) mounted on fixed roof.
7. Raise hinged sidewall and complete extension of expandable side in accordance with paragraph 2-12.

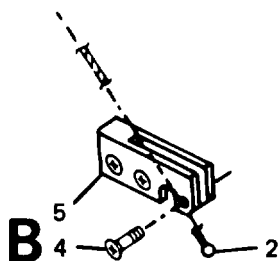
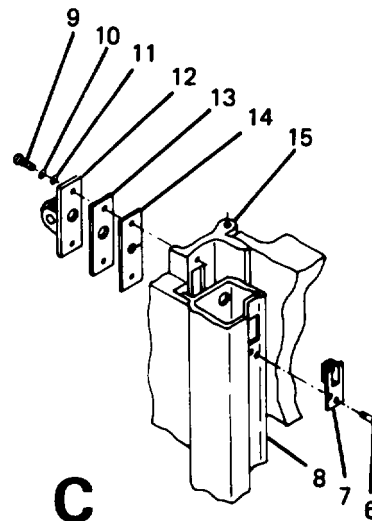
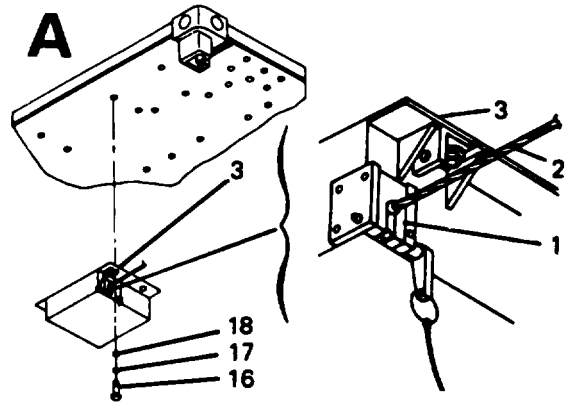

4-28. FLOOR PANEL REPAIR

This task covers:

- a. Disassembly
 - b. Cleaning, Inspection
 - c. Assembly
-

INITIAL SETUP

Special Tools

Blind bolt removal tool kit,
Appendix B, Item 13
Installation tool, Appendix B,
Item 14

Standard Tools

General mechanics tool kit

Personnel - 4

Equipment Condition

Floor panel removed

Materials

Adhesive, Item 3, Appendix E
Sealing Compound, Item 19,
Appendix E

DI SASSEMBLY

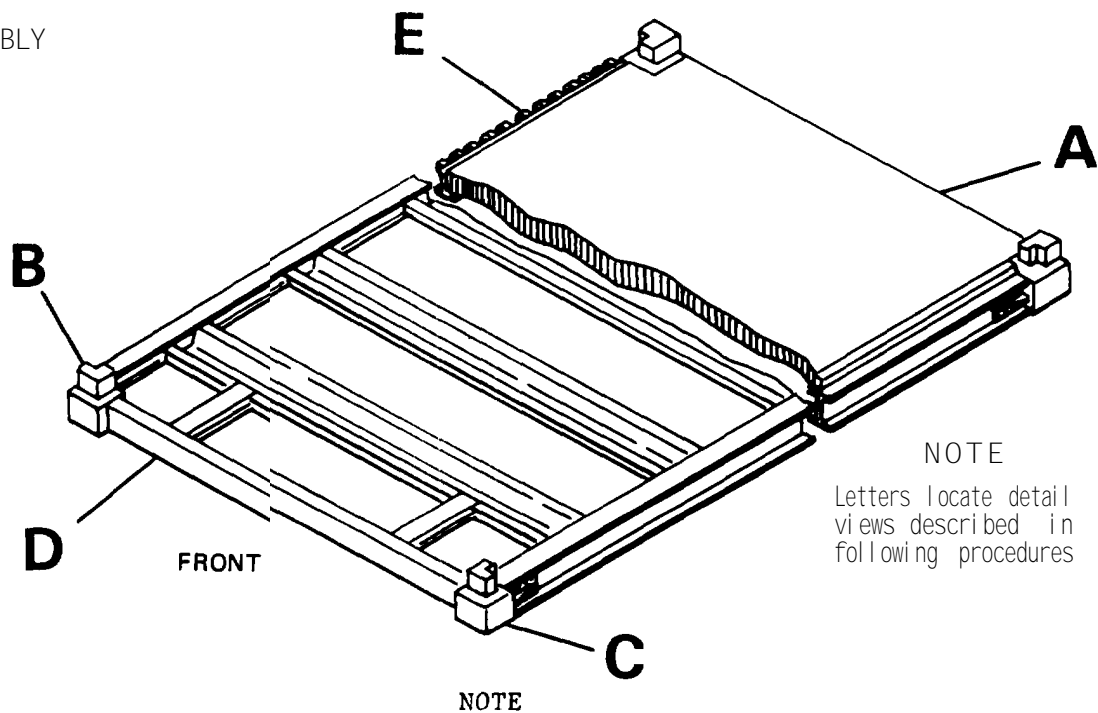

Raise floor or turn over to remove base frame.

1. Remove screws (1), lockwashers (2), and washers (3) securing base frame (4) to floor panel (5).

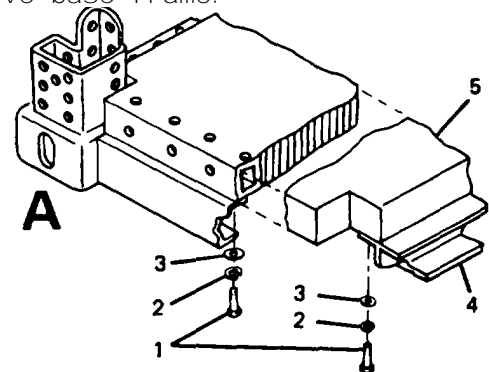

4-28. (cont)

2. Remove nuts (6), lockwashers (7), washers (8), and bolts (9) securing lower ISO fittings (10 and 11) to base frame (4).
3. Remove nuts (12), lockwashers (13), washers (14), bolts (15), and screws (16) securing lower mobilizer fitting (17) and spacer (18) to base frame (4).
4. Remove nuts (19), lockwashers (20), washers (21), and bolts (22) securing brackets (23) to base frame (4).

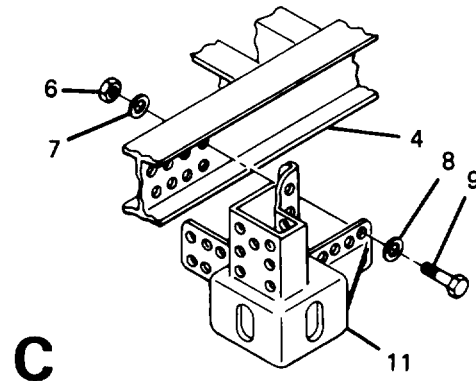
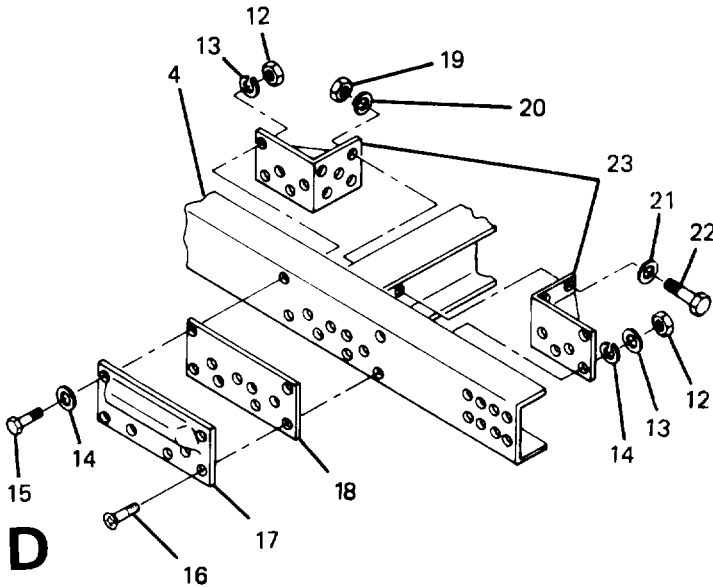
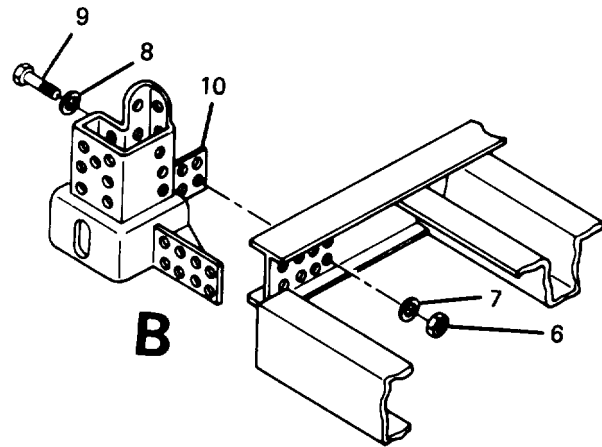

5. Using blind bolt removal tool kit, remove 224 rivets (24) and two hinge edge members (25). (Refer to paragraph 4-32)

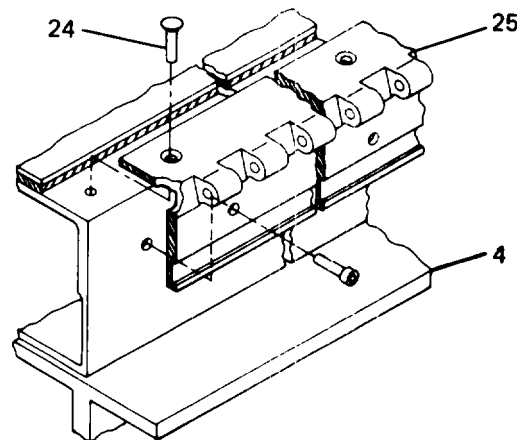

4-28. (cont)

CLEANING, INSPECTION

1. Clean panel and component surfaces.
2. Inspect mounting surfaces for corrosion and damage.
3. Inspect for and replace if necessary:
 - a. Missing or damaged components
 - b. Corrosion or paint damage.

REPAIR

1. Panel skin damage (Refer to paragraph 4-32 through 4-43.)
2. Corrosion or paint damage. (Refer to paragraph 4-44)

ASSEMBLY

1. Using installation tool, assemble two hinge edge members (25) to base frame (4) with 224 rivets (24). (Refer to paragraph 4-32)
2. Position brackets (23) on base frame channel (4) and install bolts (22), washers (21), lockwashers (20), and nuts (19).
3. Position spacer (18) and lower mobilizer fitting (17) on base frame (4) and install screws (16), bolts (15), washers (14), lockwashers (13), and nuts (12).

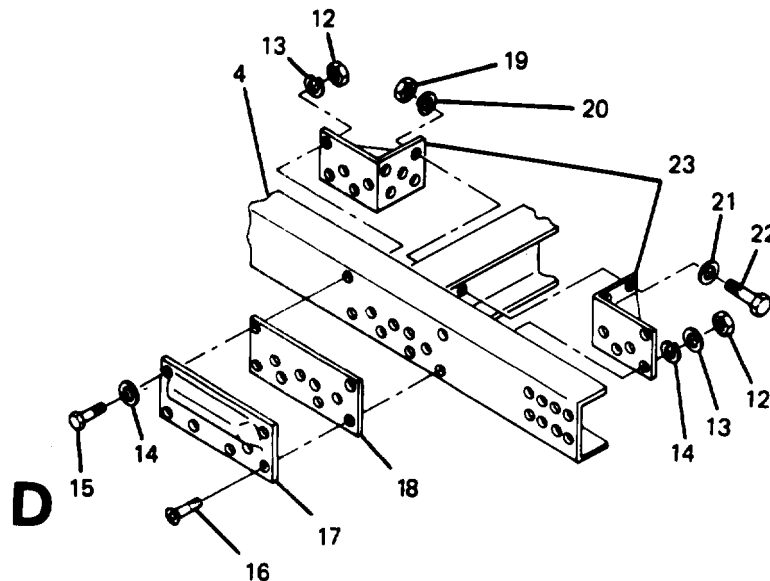
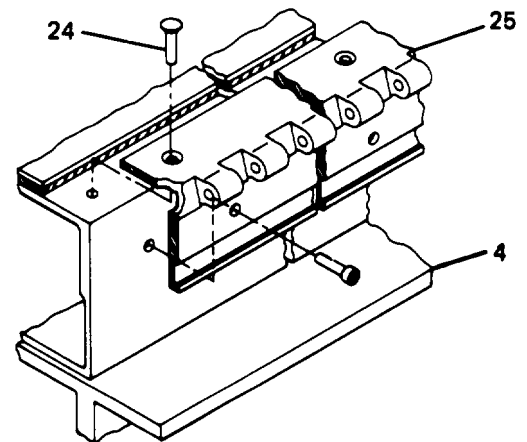

4-28. (cont)

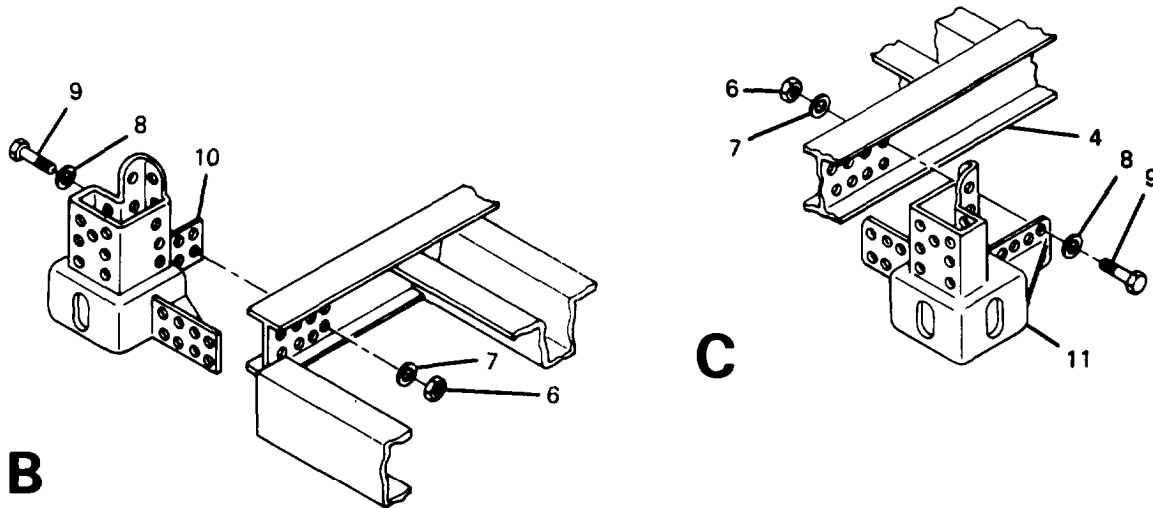

4. Position lower ISO fittings (10) and 11) on base frame (4) and install bolts (9), washers (8), lockwashers (7), and nuts (6).
5. Position base frame (4) on floor panel (5) and install washers (3), lockwashers (2), and screws (1).

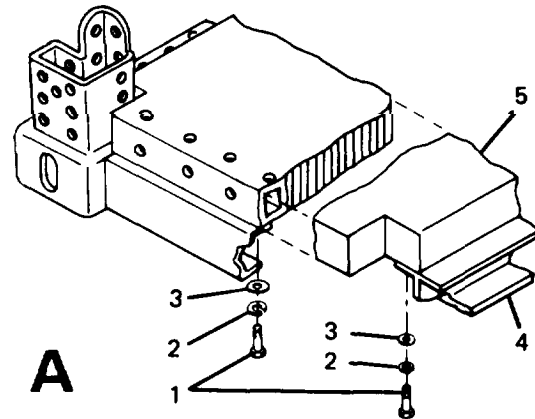

4-29. CAMLOCK AND LATCH CAM HANDLE REPLACEMENT AND REPAIR

This task covers:

- | | |
|-------------------------|-----------------|
| a. Removal | c. Repair |
| b. Cleaning, Inspection | d. Installation |

INITIAL SETUP

Standard tools

General mechanics tool kit

REMOVAL

1. Remove cotter pin (1), washer (2), and pin (3) and remove latch cam handle (4)

4-29. (cont)

2. Remove washers (5), spring washers (6), and camlock (7).

CLEANING, INSPECTION

1. Clean camlock and latch cam handle.
2. Inspect for and replace if necessary:
 - a. Missing or damaged components
 - b. Corrosion or paint damage.

REPAIR

Corrosion or paint damage. (Refer to paragraph 4-43)

INSTALLATION

1. Position camlock (7) and install washers (5), spring washers (6), and latch cam handle (4).
2. Install pin (3), washer (2), and cotter pin (1).

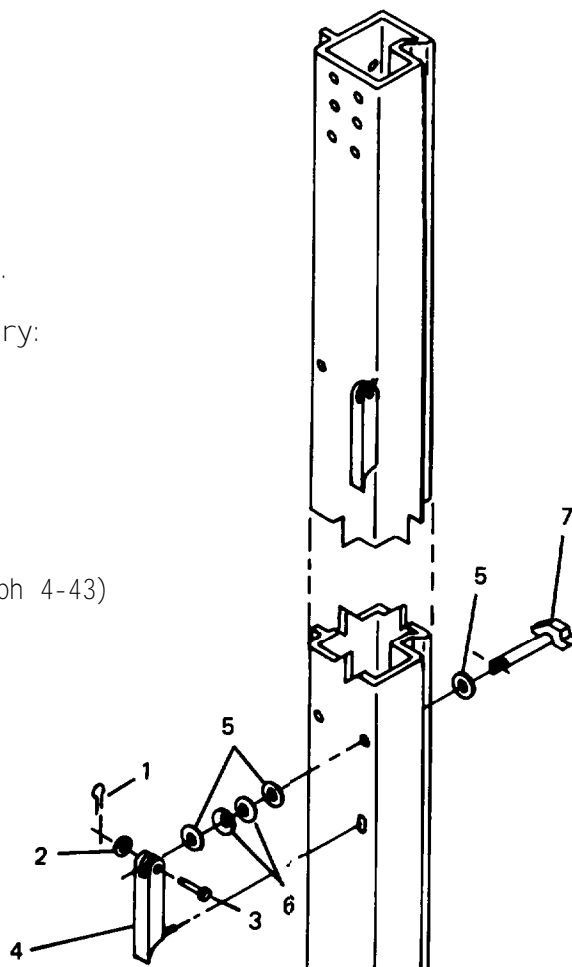

NOTE

Compress springs slightly to insert pin.

4-30. EQUIPMENT CONTAINER REPLACEMENT AND REPAIR

This task covers:

- | | |
|-------------------------|-----------------|
| a. Removal | c. Repair |
| b. Cleaning, Inspection | d. Installation |

INITIAL SETUP

Special tools

Hand blind riveter, Appendix B, Item 2
Personnel - 2

Standard Tools

General mechanics tool kit

4-30. (cont)

REMOVAL

1. Unscrew two tie-down rings (1) at the end of two strap assemblies (2) from floor panel.
2. Lift equipment container (3) from floor and remove from shelter.
3. Remove rivets (4) and chest handles (5). (Refer to paragraph 4-32)
4. Remove rivets (6) and hinges (7). (Refer to paragraph 4-32)
5. Remove rivets (8) and safety hasp (9). (Refer to paragraph 4-32)
6. Remove rivets (10) and draw pull catches (11). (Refer to para. 4-32)

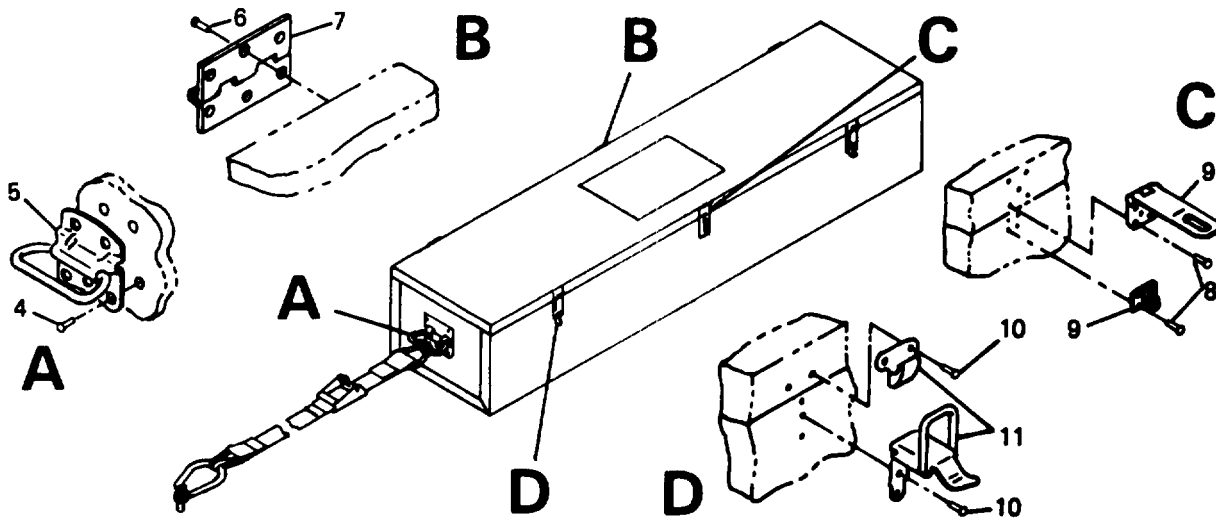

CLEANING, INSPECTION

1. Clean equipment container and component surfaces.
2. Inspect mounting surfaces for corrosion and damage.
3. Inspect for and replace if necessary:
 - a. Missing or damaged components.
 - b. Corrosion or paint damage.

REPAIR

1. Corrosion or paint damage (Refer to paragraph 4-43)
2. Replace damaged tie-down ring or strap assembly.

4-30. (cont)

INSTALLATION

1. Position draw pull catches (11) on equipment container (3) and secure with rivets (10). (Refer to paragraph 4-32)
2. Position safety hasp (9) on equipment container (3) and secure with rivets (8). (Refer to paragraph 4-32)
3. Position hinges (7) on equipment container (3) and secure with rivets (6). (Refer to paragraph 4-32)
- 4* Position chest handles (5) on equipment container (3) and secure with rivets (4). (Refer to paragraph 4-32)
5. Position equipment container (3) on floor panel.
6. Install two tie-down rings (1) at the end of two strap assemblies (2) in holes in floor panel to secure equipment container (3) to floor.

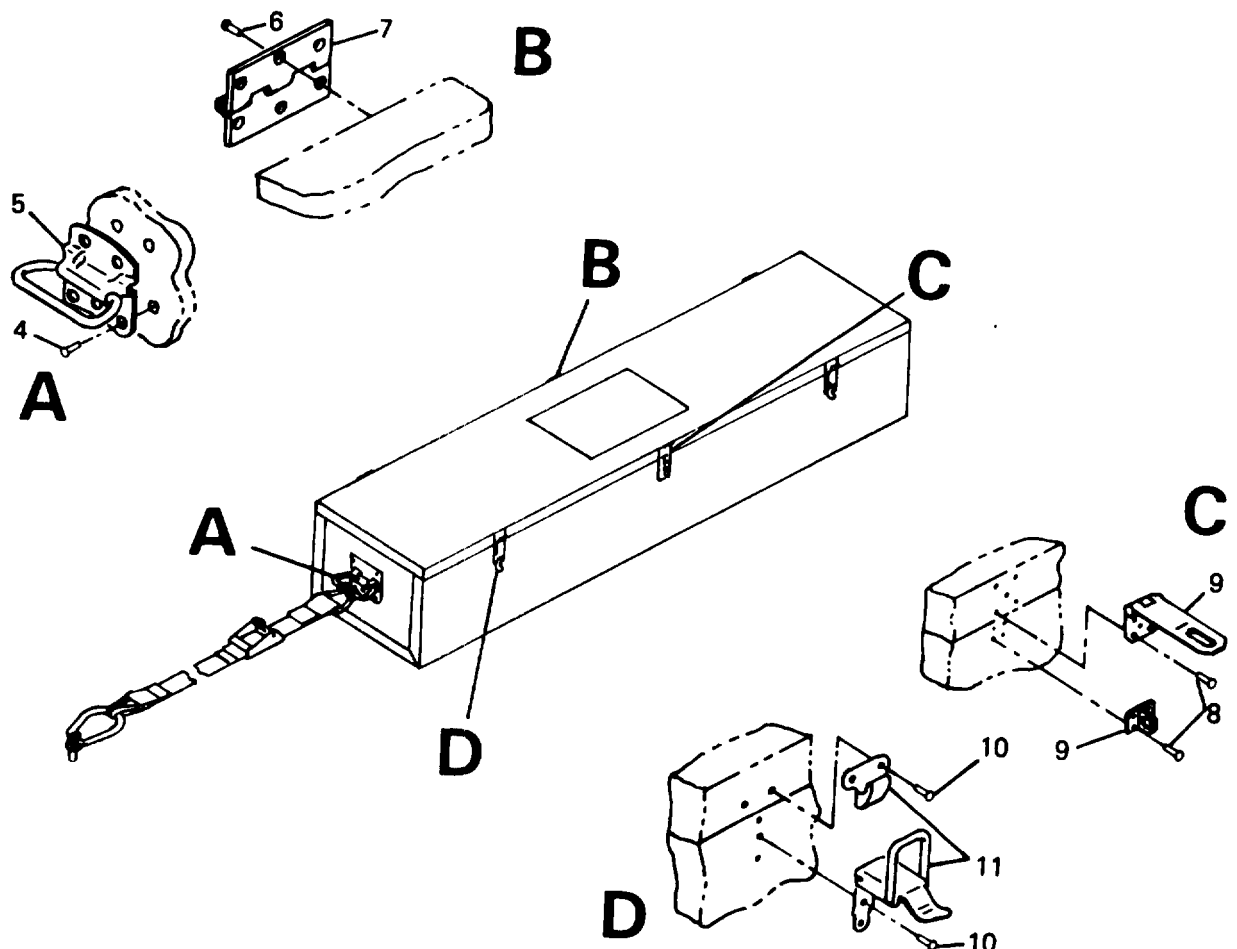

NOTE

The procedures in paragraphs 4-31 through 4-43 are typical and apply for all panel surfaces.

4-31. DRYING WATER-SOAKED AREAS IN PANELS.

- a. Care shall be taken to prevent water from entering panel core material, since it is very difficult to remove. When damage occurs, the punctured panel skin shall be temporarily protected to prevent entry of water until repair can be made. If water has been allowed to enter panel, the core material shall be dried prior to skin repair.
- b. Position heat lamps around damaged area. Adjust lamps so that panel surface temperature does not exceed 200°F (93.3°C).
- c. Allow heat lamps to remain in position until core material surrounding damaged area is thoroughly dry.

NOTE

Drying time will vary and is determined by experience and amount of moisture in panel. Core material will feel hard and brittle when dry.

- d. After core material is thoroughly dried, repair panel in accordance with the applicable repair task.

4-32. BLIND RIVET REMOVAL AND INSTALLATION.

- a. Remove blind rivets as follows:

WARNING

Wear safety goggles for eye protection from flying metal chips.

- (1) Select drill bit the same diameter as installed blind rivet.
- (2) Install selected drill bit in hand drill chuck.

4-32. (cont)

(3) Hold drill perpendicular to the surface to prevent enlargement or damage to existing hole.

(4) Drill through center of rivet just deep enough to sever rivet head from shank.

(5) Remove remainder of rivet with a pin punch.

(6) Deburr rivet hole.

b. Install blind rivets as follows:

(1) Select proper diameter and length of blind rivet (Items 13-16, Appendix E).

(2) Select appropriate nose piece for hand blind riveter and install nose piece.

(3) Wet rivet with sealant (Item 18, Appendix E) and insert rivet in hole.

(4) Holding hand blind riveter at right angle to work, install on blind rivet stem.

(5) Push against work with just enough force to firmly seat rivet and prevent part separation.

(6) Actuate and pull rivet until stem breaks.

(7) Trim broken stem flush with rivet head.

(8) Firmly press on installed rivet to check tightness of installation.

(9) Remove and replace in accordance with procedure if installation is unacceptable.

c. Blind bolt removal.

(1) The blind bolt (BP-T & B100-T) can be removed by using the proper size blind bolt removal tool kit and any portable electric drill with a rated speed of no more than 1250 RPM.

(2) The tools in this kit are illustrated on page 4-183, and are tabulated on page 4-184.

(3) The fastener removal consists of four operations:

(a) Operation 1 - Drill pin. (See page 4-186)

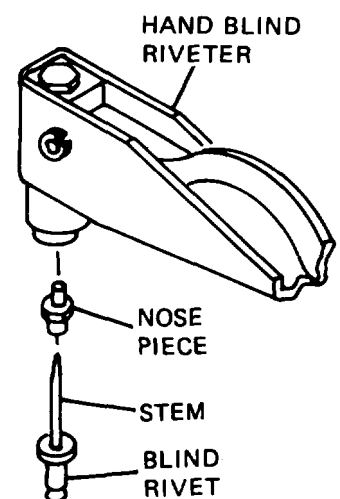
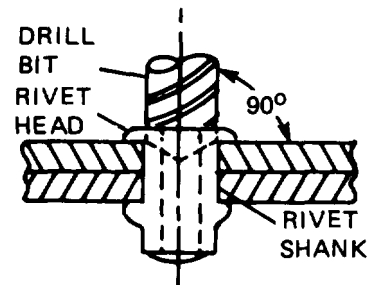
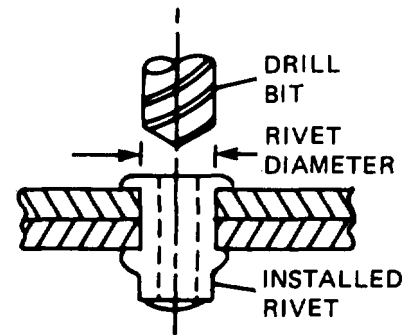

4-32. (cont)

(b) Operation II - Knock out drilled pin and remove upper portion of pin and lock collar. (See page 4-187)

(c) Operation III - Counterbore sleeve. (See page 4-188)

(d) Operation IV - Knock out counterbored sleeve and remove head of sleeve. (See page 4-189)

NOTE

The illustration of the operations for removal show a countersunk blind bolt. The removal of a protruding head blind bolt is the same. A micro-limit tool is used with the counterbore cutter in Operation III to control the depth of the cut.

TABLE I				
VISUAL INSPECTION TABLE				
Rivet Dia.	Collar Position "A" max.	Lock Position		Minimum Blind Head Diameter
		"B" max. above	"C" max. below	
3/16"	.022"	.012"	.012"	.238"
1/4"	.029"	.015"	.015"	.315"

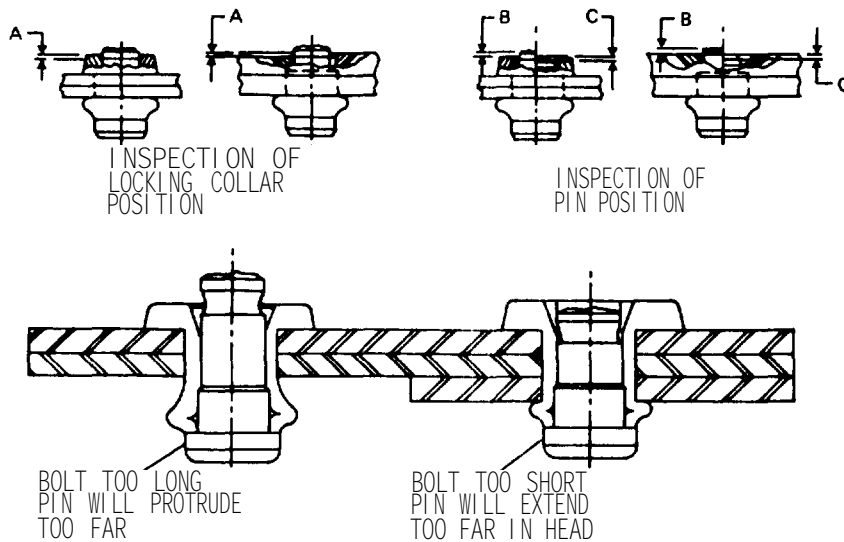

- A - Maximum allowable distance of locking collar above or below fastener head.
- B - Maximum allowable distance of top of land on pin above fastener head.
- C - Maximum allowable distance of top of land on pin below fastener head.

4-32. (cont)

Blind Bolt Removal Tool Kts

Fasteners	Nom. Size	Kit No.
BP-T6, B100-T6	3/16"	105-60
BP-T8, B100-T8	1/4"	105-80

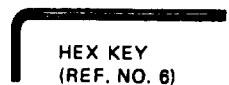
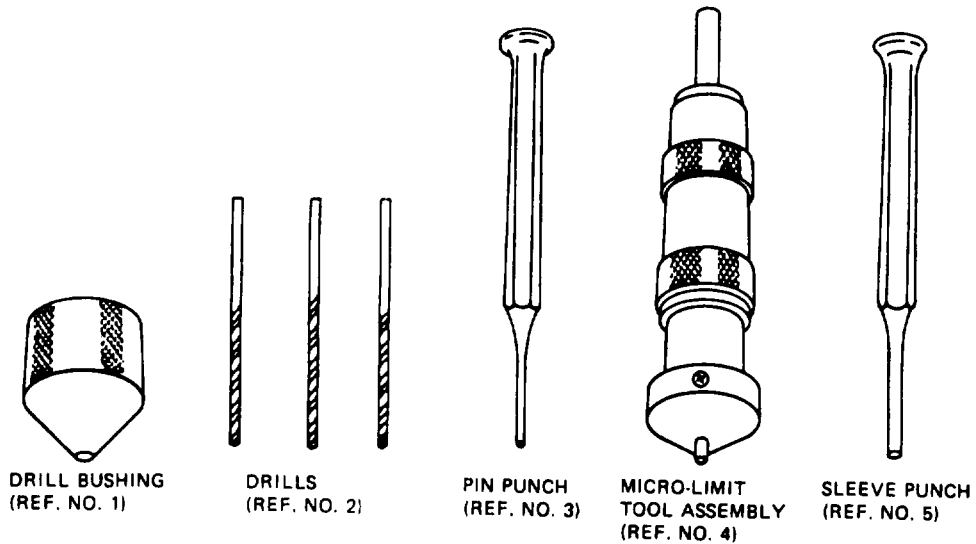

COMPOSITE PARTS LIST

Ref. No.	Description	105-60		105-80	
		Part No.	Req.	Part No.	Req.
4	Micro-Limit Tool Assembly	103601	1	103602	1
4-1	Micro-Limit Tool	103623	1	103623	1
4-2	Cutter Holder	110672-6	1	110672-6	1
4-3	Set Screw	501775	3	501775	3
4-4	Cutter	103606	1	103607	1
4-5	Anti-Rotation	103620	1	103621	1
3	Pin Punch	503010	1	503012	1
5	Sleeve Punch	503013	1	503015	1
2	Drill	503000	3	503001	3
1	Drill Bushing	103616	1	103617	1
6	Hex Key	502443	1	502443	1
	Case	103567	1	103567	1

4-32. (cont)

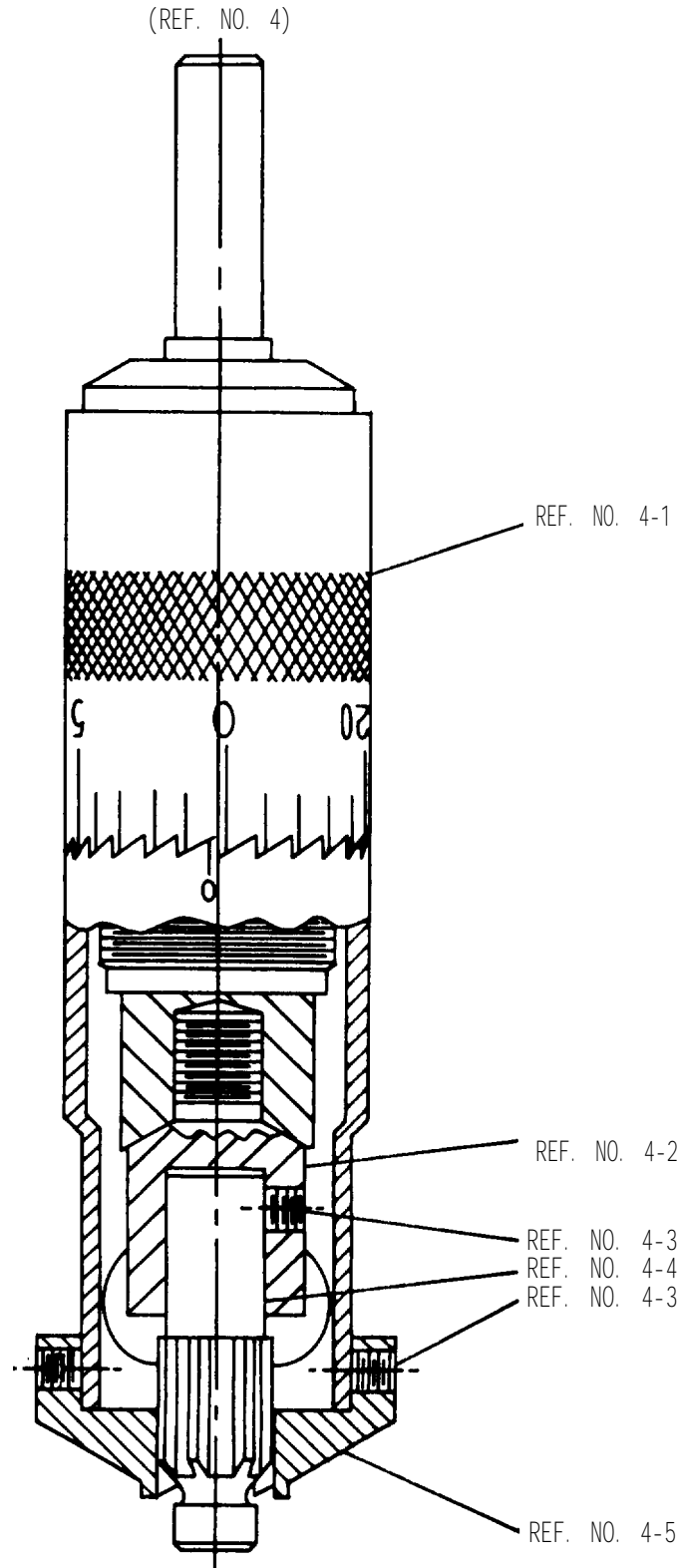

Micro-Limit Tool Assembly

4-32. (cont)

Drill

Nom. Size	Drill	Size	Min. Depth*	Bushing
3/16"	503000	.1200	.070	103616
1/4"	503001	.1562	.090	103617

* MAX. Depth + .020

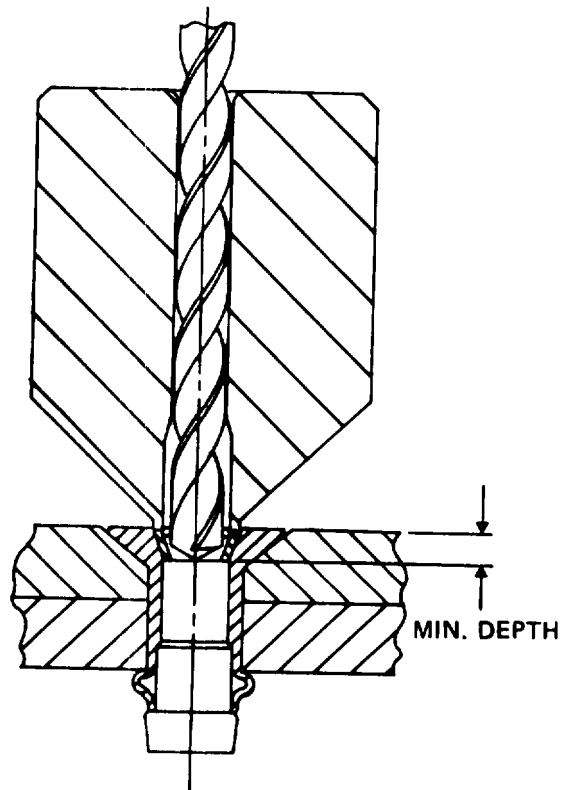

d. Operation I - Drill Pin

(1) Place the drill bushing over the pin so that it rests squarely on the lock collar.

(2) Using a drill with a maximum of 1250 RPM, drill to lock collar depth.

4-32. (cont)

Pin Punch

Nom. Size	Part No.	Size
3/16"	503010	3/32"
1/4"	503012	3/32"

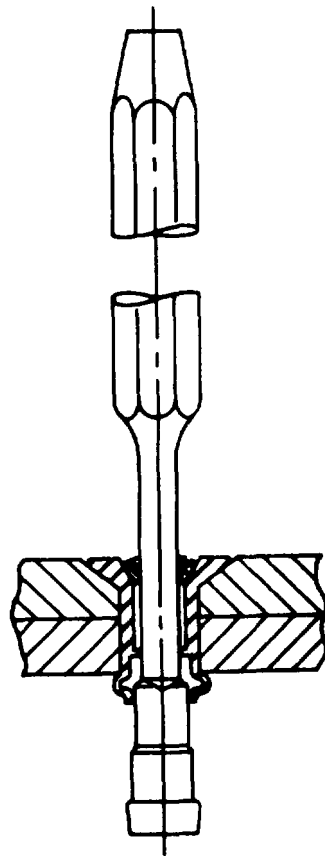

- e. Operation II - Knock Out Pin
- (1) Position pin punch on the fastener and drive fastener pin out.
 - (2) Remove remaining portion of pin and lock collar with any sharp pointed instrument.

4-32. (cont)

Cutter

Nom. Size	Holder	Cutter	Size	Anti-Rotation Cap
3/16" 1/4"	103611 103611	103606 103607	3/16" 1/4"	103620 103621

Head Height	
Protruding Head	C/Sunk Head
3/16" .135	.080
1/4" .140	.105

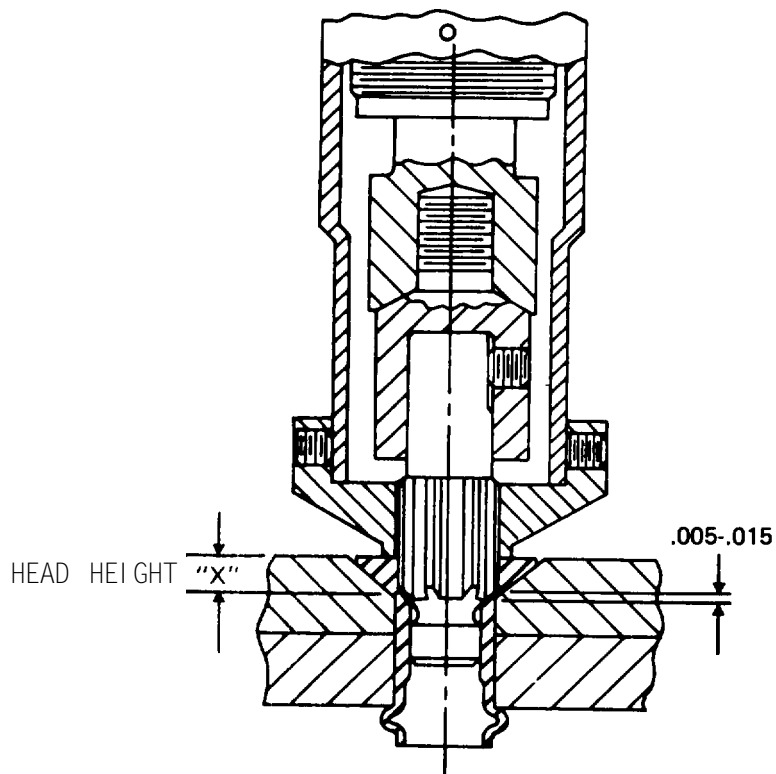

f. Operation III - Counterbore Sleeve

- (1) Adjust micro-limit tool to within .005 to .015 less than dimension on "x".
- (2) Place anti-rotation cap firmly against head of fastener.
- (3) Counterbore to desired depth.

4-32. (cont)

Sleeve Punch

Nom. Size	Part No.	Size
3/16"	503013	3/16"
1/4"	503015	1/4"

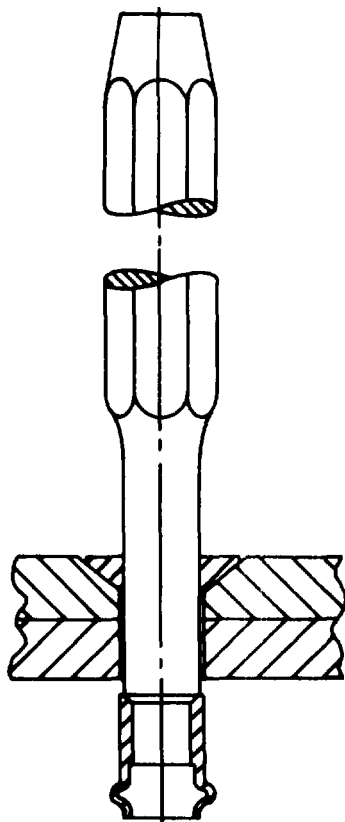

g. Operation IV - Knock Out Sleeve

(1) Position the sleeve punch in the sleeve and drive out lower portion of the sleeve.

(2) Tip the sleeve punch slightly and lift out the head of the fastener.

h. Tool Selection and Single Action Installation Sequence

NOTE

3/16" Fasteners are color identified green on pintail, shear cap or shear flange.

4-32. (cont)

SINGLE ACTION FASTENERS	DIA. DASH No.	NOM. DIA.	INSTALLATION TOOL SINGLE ACTION	NOSE ASSEMBLY SINGLE ACTION
MS90353S (SB100-T) MS90354S (SBP-T) SB100-EU & SBP-EU OSB100-T & OSBP-T	06	3/16	115	99-681
MS90353 (B100-T) MS90354 (BP-T) MS21140 (B 100-EU) MS21141 (BP-EU) OB 100-T OBP-T	08	1/4	115	99-591

(1) During the initial part of the driving operation, the sleeve is squeezed between the head of the pin and the nose of the rivet tool.

(2) The head of the pin upsets the sleeve to form a strong, bulbed head on the blind side.

(3) When the blind head has been formed, the tool automatically forces the locking collar (at the pintail end of the sleeve) into the conical space between the recess in the head and the locking groove in the pin. This locks the parts together permanently.

(4) Pin is broken off in tension at the breakneck groove, substantially flush with the head of the sleeve. There is no projecting pin left to be cut off in a separate operation.

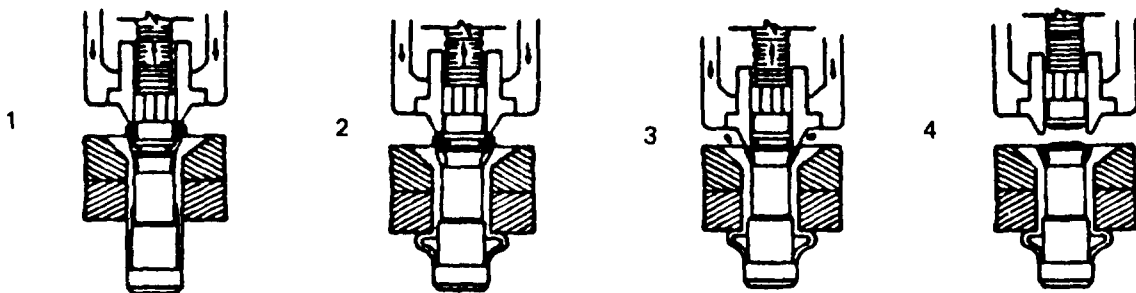

4-33. REPAIR OF SMALL DENT OR DEPRESSION.

NOTE

The following procedure covers repair of small dents or depressions in any shelter panel skin (damaged area not exceeding 2 square in. (12.9 sq. cm) or 0.25 in. (6.4 mm) deep and no evidence of delamination).

WARNING

Methyl ethyl ketone is flammable and toxic and shall be used only in a well-ventilated area away from all sparks or open flame. Gloves should be worn during use.

a. Remove all traces of paint from damaged area with sandpaper (Item 17, Appendix E).

b. Wipe sanded surface with clean cloth (Item 5, Appendix E) dampened in solvent (Item 20, Appendix E) and immediately wipe solvent from surface with a clean, dry cloth.

Mask sanded surface with masking tape (Item 22, Appendix E).

d. Mix small quantity of adhesive (Item 1, Appendix E) in accordance with manufacturer's instructions.

4-33. (cont)

e. Using spatula or putty knife, fill damaged area with adhesive.

f. Apply heat using tripod base heat lamp, Appendix B, Item 16, at 200° F (93.3°C) for 40 to 60 minutes to fully cure adhesive. Alternate cures: 150° F for 4 hours or 75° F for 72 hours.

g. Sand surface of cured adhesive to conform to surrounding area.

h. Remove masking tape and clean repaired surface.

i. Refinish in accordance with paragraph 4-43.

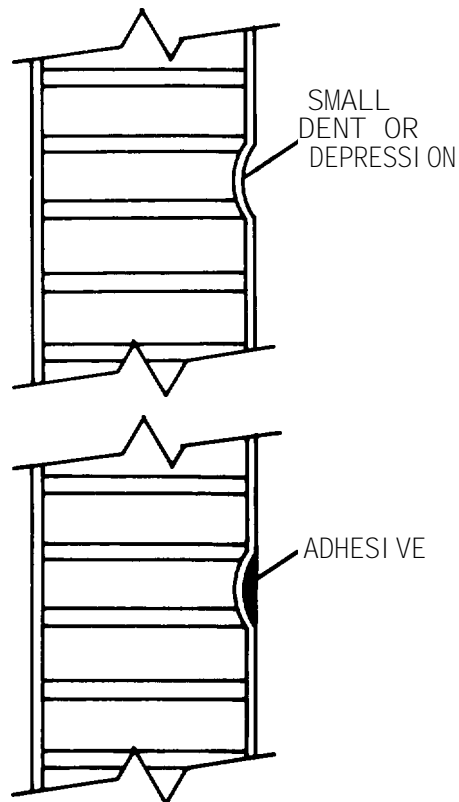

4-34. REPAIR OF DEPRESSION OR SMALL PUNCTURE.

NOTE

The following procedure covers repair of a depression or small puncture in any shelter panel skin (depression exceeding 2 square in. (12.9 sq cm) or deeper than 0.25 in. (6.4 mm) but not larger than 4 square in. (25.8 sq cm) or puncture not larger than 1 square in. (6.5 sq cm)).

WARNING

Wear safety goggles for eye protection from flying metal chips.

a. Drill two 1/8 in. (3.18 mm) diameter holes within damaged area.

b. Dry panel per paragraph 4-31, if required.

c. Mix small quantity of adhesive (Item 1, Appendix E) in accordance with manufacturer's Instructions.

d. Transfer adhesive to caulking gun and inject adhesive through two drilled holes to fill core cells completely.

e. Apply heat using tripod base heat lamp, Appendix B, -item 16, at 200°F (93.3°C) for 40 to 60 minutes to fully cure adhesive. Alternate cures: 150° F for 4 hours or 75° F for 72 hours.

f. Check by tapping damaged area to ensure complete filling of cells.

g. Sand damaged area with sandpaper (Item 17, Appendix E) to remove all traces of paint and excess adhesive.

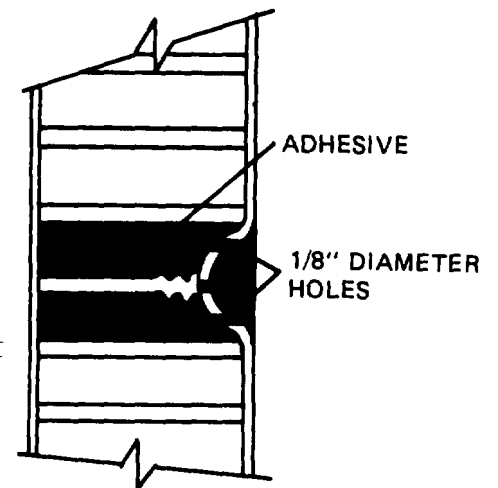

WARNING

Methylethylketone is flammable and toxic and shall be used only in a well-ventilated area away from all sparks or open flame. Gloves should be worn during use.

4-34. (cont)

- h. Wipe sanded surface with clean cloth (Item 5, Appendix E) dampened in solvent (Item 20, Appendix E) and immediately wipe solvent from surface with a clean, dry cloth.
- i. Mask sanded surface with masking tape (Item 22, Appendix E).
- j. Mix small quantity of adhesive in accordance with manufacturer's instructions.
- k. Using spatula or putty knife, fill damaged area with adhesive.
- l. Apply external heat source at 200°F (93.3°C) for 40 to 60 minutes to fully cure adhesive.
- m. Sand surface of cured adhesive to conform to surrounding area.
- n. Remove masking tape and clean repaired surface.
- o. Refinish in accordance with paragraph 4-43)

4-35. REPAIR OF PUNCTURE WITH MINIMAL DAMAGE TO CORE.

NOTE

The following procedure covers repair of puncture in any shelter panel skin with minimal core damage, (damaged area not exceeding 14 square in. (90.3 sq cm)). Use hand router to cut patches and openings.

- a. Dry panel per paragraph 4-31, if required.
- b. Using portable electric router, Appendix B, Item 15, cut aluminum patch (Item 4, Appendix E) one inch larger all around than damaged area.

WARNING

Wear safety goggles for eye protection from flying metal chips.

- c. Layout and drill holes as shown.
- d. Center patch over damaged area and mark patch outline on panel skin.
- e. Sand all paint from damaged panel skin within marked area, with sandpaper (Item 17, Appendix E).

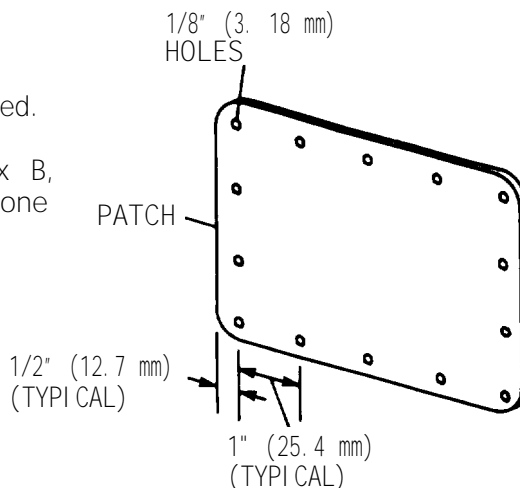

4-35. (cont)

f. Center patch over damaged area and drill No. 30 diameter holes in panel skin. Use holes in patch as a template.

g. Index patch and panel skin with a mark to allow patch to be replaced in same orientation.

h. Deburr all drill holes.

WARNING

Methylethylketone is flammable and toxic and shall be used only in a well-ventilated area away from all sparks or open flame. Gloves should be worn during use.

i. Wipe damaged area and patch with a clean cloth (Item 5, Appendix E) dampened in solvent (Item 20, Appendix E) and immediately wipe solvent from surfaces with a clean, dry cloth. Do not allow solvent to get into exposed core.

j. Mix sufficient amount of adhesive (Item 1, Appendix E) in accordance with manufacturer's instructions,

k. Pack adhesive in puncture and all exposed core cells. Use mixing sticks (Item 21, Appendix E) to pack adhesive and obtain a smooth surface.

l. Apply a thick film of remaining adhesive to mating surface of patch.

m. Place patch over prepared area in same orientation used in step f.

n. Align holes and, using hand blind riveter, install 1/8 in. (3.18 mm) diameter blind rivets (Items 15-16, Appendix E). (Refer to paragraph 4-32.)

o. Clean repaired surface.

p. Caulk around patch. (Refer to paragraph 4-42.)

q. Refinish in accordance with paragraph 4-43.

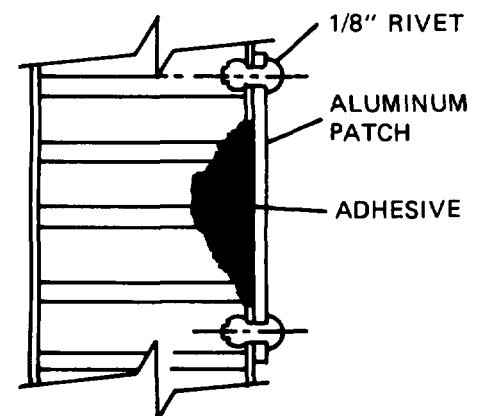

4-36. REPAIR OF PUNCTURE WITH CORE FRACTURE.

NOTE

The following procedure covers repair of any shelter panel punctured skin with core fracture, (damaged area not exceeding 25 square in. 161 sq cm)). Use hand router to cut patches and openings.

WARNING

Wear safety goggles for eye protection from flying metal chips.

- a. Dry panel per paragraph 4-31, if required.
- b. Cut an opening through panel skin with a portable electric router, Appendix B, Item 15, that is one inch greater than damaged area. Avoid sharp corners in opening.
- c. Peel damaged portion of skin from core by lifting and rolling skin.
- d. Remove all loose core from exposed core area with compressed air.
- e. Cut aluminum patch (Item 4, Appendix E) one inch larger all around than cutout opening.

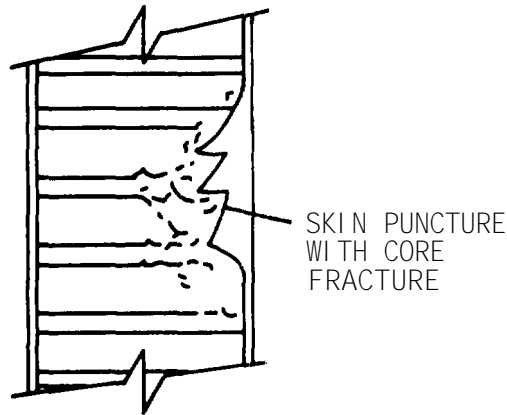

- f. Layout and drill holes as shown.
- g. Mix sufficient amount of adhesive (Item 1, Appendix E) in accordance with manufacturer's instructions.
- h. Pack adhesive in core cells to fill exposed area above surface of panel skin.
- i. Apply heat using tripod base heat lamp, Appendix B, Item 16, at 200°F (93.3°C) for 40 to 60 minutes to fully cure adhesive. Alternate cures: 150° F for 4 hours or 75° F for 72 hours.

4-36. (cont)

j. Sand cured adhesive with sandpaper (Item 17, Appendix E) to obtain a smooth contour with surface of panel skin.

k. Center patch over adhesive-filled area and mark patch outline on panel skin.

l. Sand all paint from damaged panel skin within marked area.

m. Center patch over filled area and drill No. 30 diameter holes in panel skin. Use holes in patch as a template.

n. Index patch and panel skin with a mark to allow patch to be replaced in same orientation.

o. Deburr all drill holes.

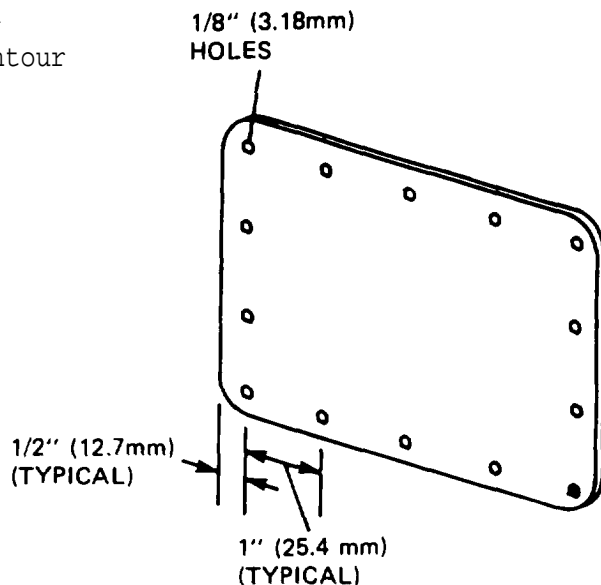

WARNING

Methylethylketone is flammable and toxic and shall be used only in a well-ventilated area away from all sparks or open flame.

p. Wipe damaged area and patch with a clean cloth (Item 5, Appendix E) dampened in solvent (Item 20, Appendix E) and immediately wipe solvent from surfaces with a clean, dry cloth.

q. Mix sufficient amount of adhesive in accordance with manufacturer's instructions to coat one side of patch.

r. Apply a thick film of adhesive to mating surface of patch.

s. Place patch over prepared area in same orientation used in step k.

t. Align holes and, using hand blind riveter, install 1/8 in. (3.18 mm) diameter blind rivets (Items 15-16, Appendix E). (Refer to paragraph 4-32.)

u. Clean repaired surface.

v. Caulk around repair patch. (Refer to paragraph 4-42.)

w. Refinish in accordance with paragraph 4-43.

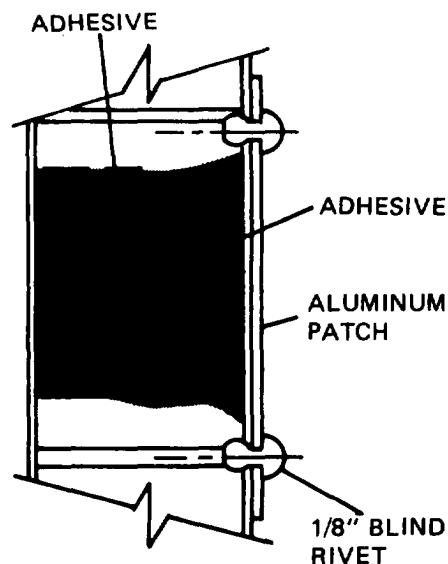

4-37. REPAIR OF DAMAGE WITH EXTENDED CRACKS.

NOTE

The following procedure covers repair of extended cracks (such as a long cut) in panel skin, (damaged area does not exceed 36 in. (91.44 cm) square).

- a. Dry panel per paragraph 4-31, if required.
- b. Using portable electric router, Appendix B, Item 15, cut aluminum patch (Item 4, -Appendix E) one inch larger all around than damaged area.

WARNING

Wear safety goggles for eye protection from flying metal chips.

- c. Layout and drill 1/8 in. (3.18 mm) holes as shown.

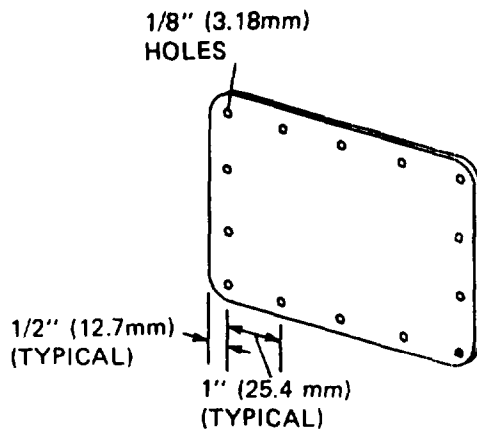

- d. Stop-drill all cracks with No. 30 (3.27 mm) drill bit.
- e. Center patch over damaged area and mark patch outline on panel skin.
- f. Sand all paint from damaged skin within marked area with sandpaper (Item 17, Appendix E).
- g. Center patch over damaged area and drill No. 30 diameter holes in panel skin. Use holes in patch as a template.
- h. Index patch and panel skin with a mark to allow patch to be replaced in same orientation.
- i. Deburr all drill holes.

4-37. (cont)

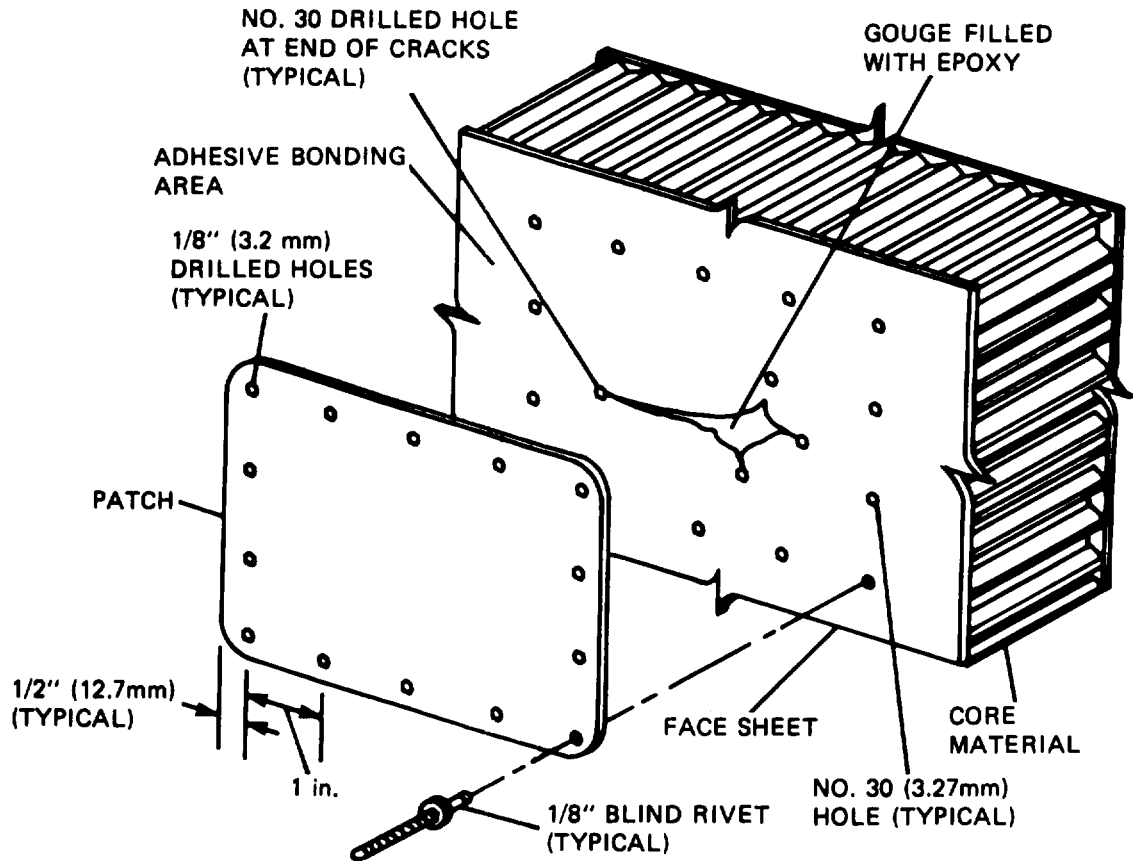

WARNING

Methylethylketone is flammable and toxic and shall be used only in a well-ventilated area away from all sparks or open flame.

j. Wipe damaged area and patch with a clean cloth (Item 5, Appendix E) dampened in solvent (Item 20, Appendix E) and immediately wipe solvent from surfaces with a clean, dry cloth.

k. Mix sufficient amount of adhesive (Item 1, Appendix E) in accordance with manufacturer's instructions.

l. Pack adhesive in core cells to fill exposed area above surface of panel skin.

m. Apply heat using tripod base heat lamp, Appendix B, item 16, at 200°F (93.3°C) for 40 to 60 minutes to fully cure adhesive. Alternate cures: 150° F for 4 hours or 75° F for 72 hours.

4-37. (cont)

- n. Sand cured adhesive with sandpaper to obtain a smooth contour with surface of panel skin.
- o. Wipe sanded area and patch with a clean cloth dampened in solvent and immediately wipe solvent from surfaces with a clean, dry cloth.
- p. Mix sufficient amount of adhesive in accordance with manufacturer's instructions to coat one side of patch.
- q. Apply a thick film of adhesive to mating surface of patch.
- r. Place patch over prepared area in same orientation used in step g.
Align holes and using hand blind riveter, install 1/8 in. (3.18 mm) diameter blind rivets (Items 15-16, Appendix E). (Refer to paragraph 4-32.)
- t. Clean repaired surface.
- u. Caulk around repair patch. (Refer to paragraph 4-42.)
- v. Refinish in accordance with paragraph 4-43.

4-38. REPAIR OF PUNCTURE THROUGH ONE SKIN AND CORE.

NOTE

The following procedure covers repair of panel puncture through one skin with core damage, (damaged area does not exceed 100 square in. (645 sq. cm)).

- a. Cut an opening through panel skin with portable electric router, Appendix B, Item 15, that is one inch greater than damaged area. Avoid sharp corners in opening.

NOTE

Openings may be oval, circular, square, or rectangular with rounded corners.

4-38. (cont)

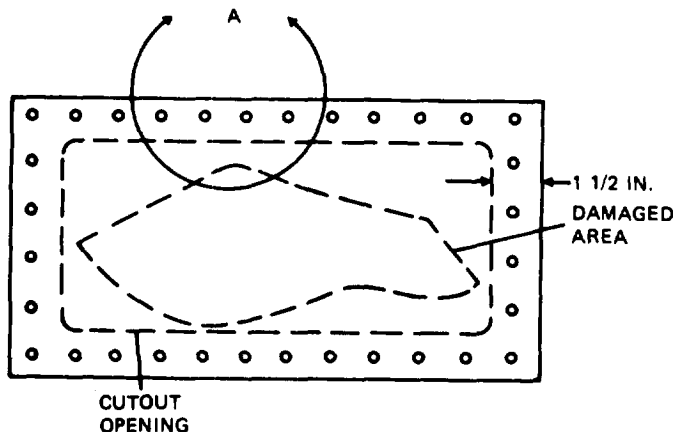
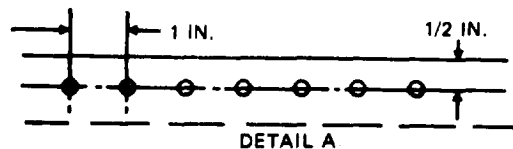

- b. Peel damaged portion of skin from core by lifting and rolling skin.
- c. Trim core area with a knife to same size as opening while leaving small amount of core material on opposite skin.
- d. Cut aluminum patch 1 1/2 inch (3.8 cm) (Item 4, Appendix E) larger all around than cutout opening.
Layout and drill 1/8 inch (3.18 mm) diameter holes in patch. (See Detail A.)
- f. Cut core material (Items 7-10, Appendix E) same size as cutout opening. Core plug should be flush with or slightly lower than panel skin surface.
- g. Center patch over cutout opening and mark patch outline on panel skin.
- h. Drill No. 30 diameter holes in panel skin with patch as template.
- i. Sand all paint from panel skin within marked area with sandpaper (Item 17, Appendix E).
- j. Index patch and panel skin with a mark to allow patch to be replaced with same orientation.
- k. Deburr drill holes and sand all paint from panel skin within marked area.
- l. Clean loose core material, dust, and chips from cutout opening.

4-38. (cont)

WARNING

Methylethylketone is flammable and toxic and shall be used only in a well-ventilated area away from sparks or open flame. Gloves should be worn during use.

m. Wipe panel skin within marked area and patch with a clean cloth (Item 5, Appendix E) dampened with solvent and immediately wipe solvent from surfaces with a clean, dry cloth.

n. Mix sufficient amount of adhesive (Item 1, Appendix E) in accordance with manufacturer's instructions.

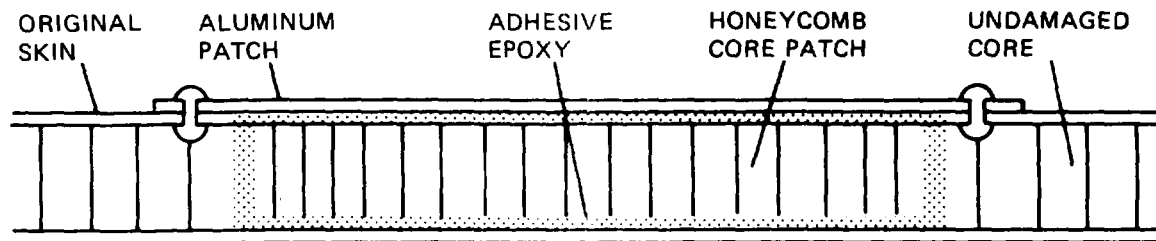

o. Apply an even coat of adhesive to cutout core surfaces.

p. Insert core plug in cutout opening and press firmly in place.

q. Apply an even coat of adhesive around core plug and fill any gaps around plug.

r. Apply heat using tripod base heat lamp, Appendix B, Item 16, at 200°F (93.3°C) for 40 to 60 minutes to fully cure adhesive. Alternate cures: 150° F (65.6°C) for 4 hours or 75° F (23.9°C) for 72 hours.

s. Sand cured adhesive with sandpaper to obtain a smooth contour with surface of panel skin.

t. Apply an even coat of adhesive to mating surface of patch.

u. Place patch over prepared area in same orientation as step j.

v. Align holes and using hand blind riveter, install 1/8 inch (3.18 mm) diameter blind rivets (Items 15-16, Appendix 5). (Refer to paragraph 4-32)

w. Clean repaired surface.

x. Caulk around repair patch. (Refer to paragraph 4-42)

y. Refinish in accordance with paragraph 4-43)

4-39. REPAIR OF PUNCTURE THROUGH BOTH SKINS AND CORE.

NOTE

The following procedures cover repair of panel puncture through both skins and core, (damage area does not exceed 100 square in. (645 sq. cm)). Use hand router to cut patches and openings.

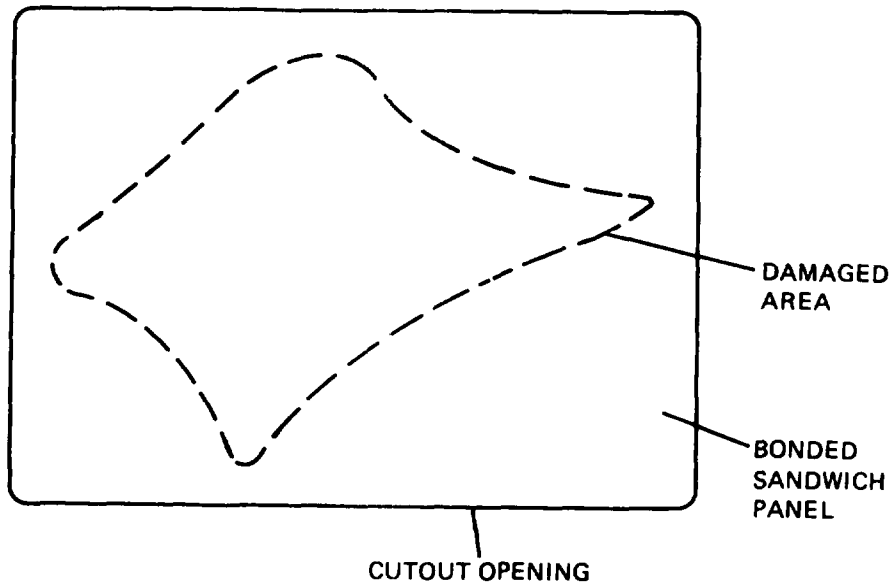

- a. Cut an opening through panel skin with portable electric router, Appendix B, Item 15, that is one inch greater than damaged area. Avoid sharp corners in opening.

NOTE

Openings may be oval, circular, square, or rectangular with rounded corners. Ensure core ribbon direction is same as panel. Dry panel per paragraph 4-31, if required.

- b. Cut a core plug and two aluminum patches (Item 4, Appendix E) one to three inches larger all around than cutout opening.
- c. Mix sufficient amount of adhesive (Item 1, Appendix E) in accordance with manufacturer's instructions to bond two patches to core plug.

WARNING

Methylethylketone is flammable and toxic and shall be used only in a well-ventilated area away from sparks or open flame. Gloves should be worn during use.

4-39. (cent)

d. Wipe patches with a clean cloth (Item 5, Appendix E) dampened with solvent and immediately wipe solvent (Item 20, Appendix E) from surfaces with a clean, dry cloth.

e. Apply a thick coat of adhesive to one side of each patch.

f. Place core plug between two patches to create a sandwich panel.

g. Apply pressure and heat using tripod base heat lamp, Appendix B, Item 16, at 200° F (93.9° C) for 40 to 60 minutes to fully cure adhesive.

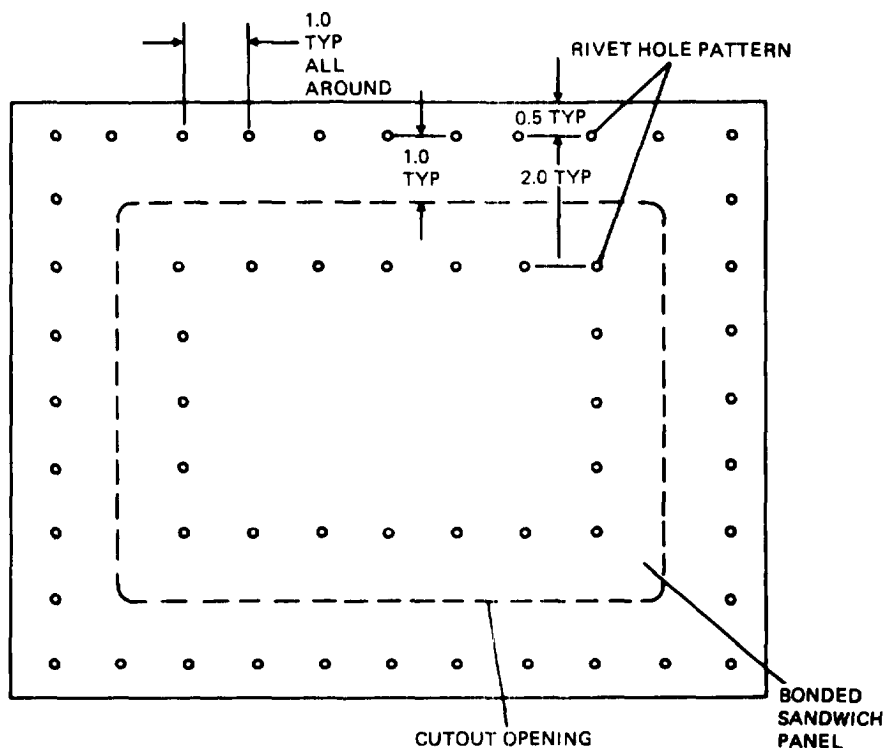

h. Cut bonded sandwich panel to same size as cutout opening (step a). Ensure core ribbon direction is same as panel.

i. Cut two aluminum patches 1 1/2 inch (3.8 cm) larger all around than cutout opening.

j. Layout and drill 1/8 inch (3.18 nun) diameter holes in patches.

k. Position bonded sandwich panel in cutout opening.

l. Center patches, one on each side of panel, over cutout opening.

m. Drill No. 30 (3.27 mm) diameter holes in panel skins and bonded sandwich panel with patches as templates.

4-39. (cont)

- n. Mark each patch outline on panel skin, and sand all paint from panel skin within marked area with sandpaper (Item 17, Appendix E).
- o. Index each patch and panel skin with a mark to allow patches to be replaced with same orientation.
- p. Remove patches and bonded sandwich panel.
- q. Deburr drill holes and sand all paint from panel skin within marked areas.
- r. Clean loose core material, dust, and chips from cutout opening.
- s. Wipe panel skin within marked areas, two patches, and bonded sandwich panel metal skin with a clean cloth dampened with solvent. Immediately wipe solvent from surfaces with a clean, dry cloth.
- t. Mix sufficient amount of adhesive in accordance with manufacturer's instructions.
- u. Apply a thick coat of adhesive to inside surfaces of panel cutout opening, bonded sandwich panel, and two patches.
- v. Position bonded sandwich panel in cutout opening.
- w. Fill any gaps between cutout opening and bonded sandwich panel with adhesive.

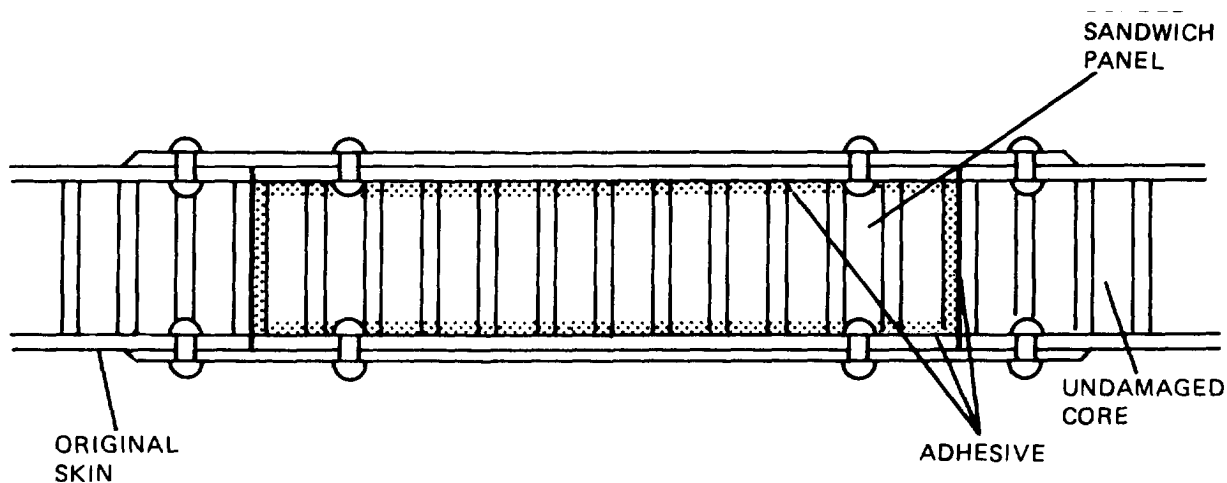

- x. Place patches over prepared areas in same orientation as step o.
- y. Align holes and using hand blind riveter, install 1/8 inch (3.18 mm) diameter blind rivets (Items 15-16, Appendix E). (Refer to paragraph 4-32)
- z. Clean repaired surfaces.
- aa. Caulk around repair patches. (Refer to paragraph 4-42)
- ab. Refinish in accordance with paragraph 4-43)

4-40. SHELTER BODY SEALS REPLACEMENT.

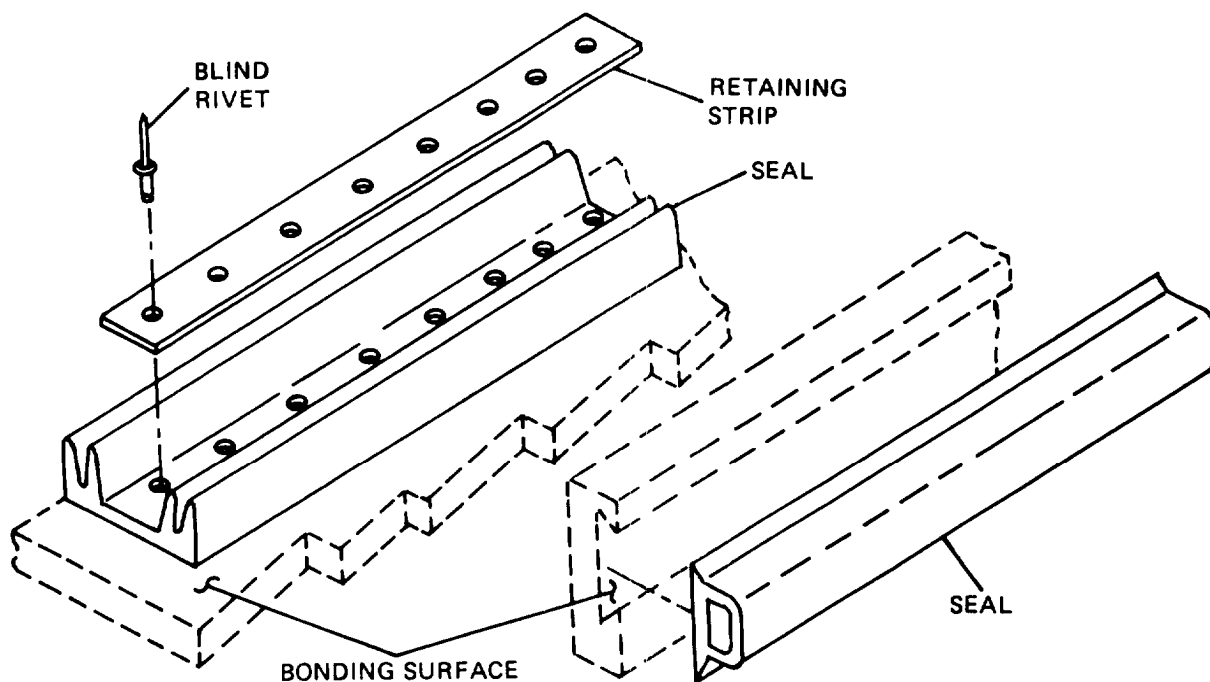

W A R N I N G

Wear safety goggles for eye protection from flying metal chips.

- a. If defective seal has a retaining strip, drill out blind rivets and remove retaining strip. (Refer to paragraph 4-32.)
- b. Remove defective seal and strip old sealant from bonding surface.

W A R N I N G

Methylethylketone is flammable and toxic and shall be used only in a well-ventilated area away from all sparks or open flame.

- c. Sand using sandpaper (Item 17, Appendix E) only if required to remove material not taken off in preceding step.
- d. Wipe bonding surface with a clean cloth (Item 5, Appendix E) dampened with solvent (Item 20, Appendix E) and immediately wipe solvent from surface with a clean, dry cloth.

4-40. (cont)

CAUTION

Seals shall not be washed with any aromatic hydrocarbon (such as benzene, toluene, or xylene) which will cause deterioration.

- e. Clean seal with a lint-free cloth by dry wiping prior to bonding.
- f. Brush sealant (Item 18, Appendix E) on mating surfaces of seal and bonding surface.
- g. When sealant is tacky (approximately 5 minutes), place seal in position, press firmly to seat and ensure contact with mating surface.
- h. If seal is the type that has a retaining strip, seal shall be bonded prior to riveting retaining strip. (Refer to paragraph 4-32 for blind rivet installation.)
- i. After installing rivets, using hand blind riveter, cover rivets and seal with sealing compound (Item 19, Appendix E).

4-41. THREADED INSERTS REPLACEMENT.

NOTE

Inserts installed in extrusions are not potted. For removal of these inserts, perform steps a and b only. Knock out insert and replace with same type.

- a. Depending on insert size, select a drill bit in size range listed below.

Insert Thread Size	Drill Size Range inches (mm)
10-32	7/16-15/32 (11/12.4)
1/4-28	17/32-21/32 (13.5/16.7)
5/16-24	39/64-21/32 (15.5/16.7)
3/8-24	43/64-23/32 (17/18.3)

4-41. (cont)

WARNING

Wear safety goggles for eye protection against flying chips.

b. Using selected drill bit, drill head flange from insert.

c. Drill small holes around insert body in potting compound to approximate depth of insert. Take care not to damage area around insert beyond hole diameter of step above. Do not drill through to opposite skin.

d. Install bolt of corresponding thread size in insert.

e. Use wrench to break insert loose.

f. Install bolt end in a hand drill motor.

g. Spin loose insert to build up heat which will allow insert to be removed from hole.

h. Remove loose chips and clean out hole.

NOTE

Replacement insert is a spool type potted insert.

i. Depending on replacement insert size, select a drill bit from sizes listed below. After drilling small holes around periphery of insert, the remaining hole will be much larger than the recommended drill size.

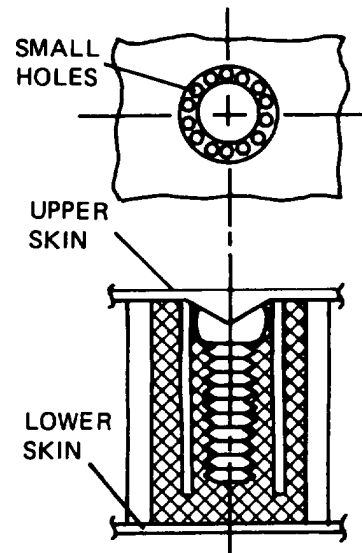
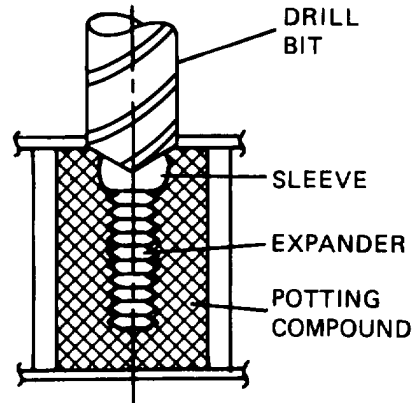

Insert Outside

Insert Thread Size	Diameter inches (mm)	Drill Size inches (mm)
1/4-28	0.437 (11.1)	29/64 ± 0.010 (11.5 ± 0.25)
5/16-24	0.500 (12.7)	33/64 ± 0.010 (13.1 ± 0.25)
10-32 & 3/8-16	0.562 (14.3)	37/64 ± 0.010 (14.7 ± 0.25)
1/4-28 & 5/16-24	0.687 (17.5)	45/64 ± 0.010 (17.9 ± 0.25)
3/8-24	0.750 (19.1)	49/64 ± 0.010 (19.5 ± 0.25)

4-41. (cont)

j. Using selected drill bit, drill through panel skin to approximate depth of insert to be installed.

NOTE

Take care not to drill through opposite skin.

k. Install long end of Allen wrench into drill chuck and insert short end in predrilled hole and remove additional honeycomb core to one inch (2.54 mm) in diameter. Leave from 1/8 in. (3.2 mm) to 1/4 in. (6.4 mm) of core at bottom of hole.

l. Remove loose honeycomb and foam insulation, if applicable, from hole.

m. Degrease insert by cleaning with solvent (Item 20, Appendix E).

NOTE

After cleaning, handle insert with clean, white gloves (Item 11, Appendix E).

n. Mask skin area around hole with masking tape (Item 22, Appendix E) approximately 3" x 3".

o. Prepare aluminum plate (Item 24, Appendix E) approximately 1/8 in. (3.2 mm) thick by 2 in. (50.8 mm) square with a center hole equal to bolt thread outer diameter (replacement insert thread size).

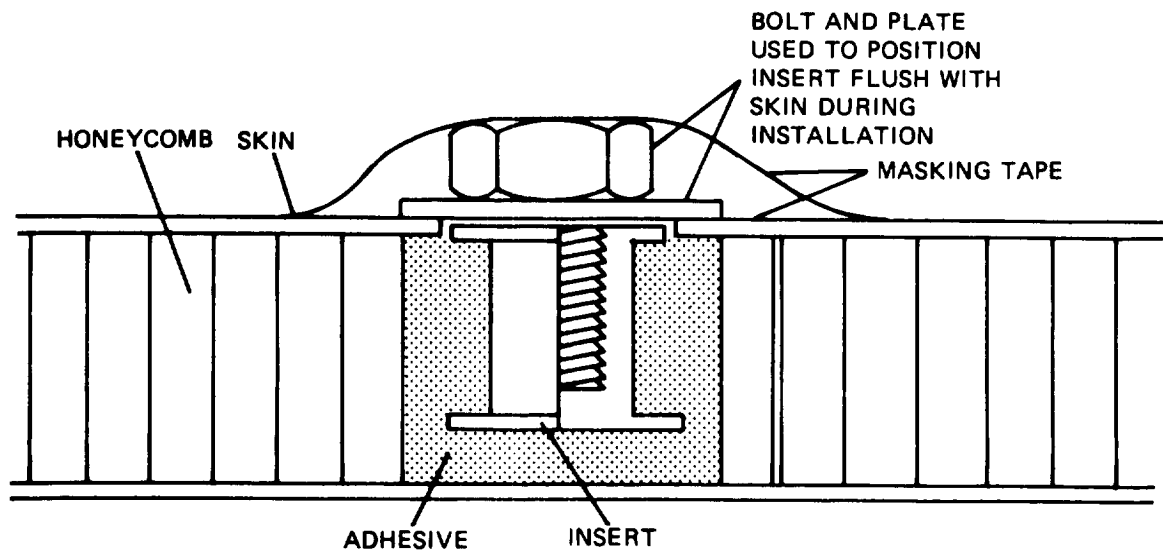

4-41. (cont)

p. Install bolt through plate and into insert. Hand-tighten insert against plate.

q. Mix sufficient amount of adhesive (Item 1, Appendix E) in accordance with manufacturer's instructions.

r. Fill prepared hole completely with mixed adhesive. Make sure there are no air pockets.

s. Force preassembled insert into filled hole with a threading motion until plate is flush against skin.

t. Clean excess adhesive (squeeze out) from work area.

u. Apply masking tape over bolt to maintain alignment during curing cycle.

v. Cure non-structural inserts for at least 4 hours at 75° F.

w. Inserts on which there is structural dependency should be cured at 75° F for 72 hours.

x. After cure, remove masking tape, bolt, and plate.

y. Clean skin as required.

z. Refinish in accordance with paragraph 4-43.

aa. Non-Potted Insert Manual Installation

(1) Select fastener header model, Appendix B, Item 7 or 8, applicable to insert to be installed.

(2) Lubricate header jackscrew threads with spray lubricant, Appendix E, Item 25.

(3) Assemble sleeve and expander or one-piece insert on header pull-up stud to engage all threads on stud.

(4) Advance header anvil until it is tight on head of sleeve or one-piece insert.

(5) Position prepared assembly in hole.

(6) Place hex wrench (supplied with header) in socket of header jackscrew and place box-end or adjustable wrench, Appendix B, Item 11, on hex nut approximately 60° rotation from line of hex wrench.

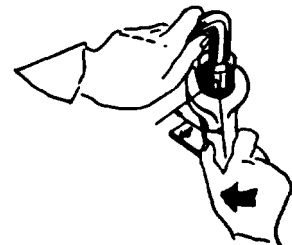

4-41. (cont)

NOTE

A box-end ratchet wrench is preferable as the pull on the expander or one-piece insert body should be made at a uniform rate and as quickly as possible.

(7) Hold header perpendicular to plane of work. Hold jackscrew stationary with hex wrench. Turn hex nut in clockwise direction through 60° angle and repeat until firm resistance indicates complete upset of sleeve or one-piece insert body. Approximate number of turns required to upset is as follows:

<u>Thread Size</u>	<u>Turns (Min Grip)</u>	<u>Turns (Max Grip)</u>
10-32	1-3/4	1
1/4-20	2-1/4	1-1/2
5/16-24	2-3/4	1-3/4
3/8-24	2-1/4	1-1/2

(8) Break hex nut loose with counterclockwise rotation. Remove both wrenches from header.

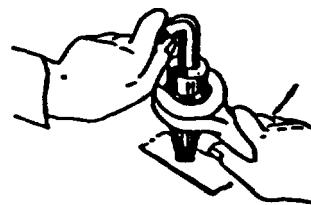

(9) Remove header from installed insert by rotating entire header in counterclockwise direction.

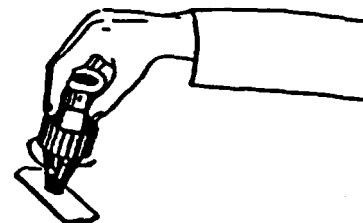

4-42. CAULKING REPAIRED AREAS

a. Mix sufficient amount of sealing compound (Item 19, Appendix E) in accordance with manufacturer's instructions.

NOTE

Maximum application life of sealing compound is 2 hours.

b. Just prior to application of sealing compound, clean surface to be sealed with cloth (Item 5, Appendix E) dampened with solvent (Item 20, Appendix E).

c. Dry with a clean cloth before solvent evaporates in order to prevent contamination.

4-42. (cont)

e. Nominal curing time is 72 hours at 75° F.

4-43. PAINT REFINISHING

Sand Paint Data Plate (with scuff strip)

THIS SHELTER PAINTED WITH CARC PAINT			
	PAINT TYPE	MIL SPEC COLOR	COLOR CODE FED-STD-595
INTERIOR PAINT	EPOXY	MIL-C-22750 WHITE	17925
EXTERIOR PAINT	ALIPHATIC POLYURETHANE	MIL-C-48168 SAND	33303
PRIMER	EPOXY	MIL-P-53022	
FLOOR PAINT	WALKWAY COMPOUND	MIL-W-5044 TYPE I GRAY	26251
FLOOR PAINT	WALKWAY COMPOUND	MIL-W-5044 TYPE II GRAY	26251

Sand Paint Data Plate (without scuff strip)

THIS SHELTER PAINTED WITH CARC PAINT			
	PAINT TYPE	MIL SPEC COLOR	COLOR CODE FED-STD-595
INTERIOR PAINT	EPOXY	MIL-C-22750 WHITE	17925
EXTERIOR PAINT	ALIPHATIC POLYURETHANE	MIL-C-46168 SAND	33303
PRIMER	EPOXY	MIL-P-53022	
FLOOR PAINT	WALKWAY COMPOUND	MIL-W-5044 TYPE I GRAY	26251

4-44. (cont)

Camouflage Paint Data Plate (with scuff strip)

THIS SHELTER PAINTED WITH CARC PAINT			
	PAINT TYPE	MIL SPEC COLOR	COLOR CODE FED-STD-595
INTERIOR PAINT	EPOXY	MIL-C-22750 GLOSS WHITE	17925
EXTERIOR PAINT	ALIPHATIC POLYURETHANE	MIL-C-46168 GREEN 383 BROWN 383 BLACK	34094 30051 37030
PRIMER	EPOXY	MIL - P - 5 3 0 2 2	
FLOOR PAINT	WALKWAY COMPOUND	MIL-W-5044 TYPE I GRAY	26251
FLOOR PAINT	WALKWAY COMPOUND	MIL-W-5044 TYPE II GRAY	26251

Camouflage Paint Data Plate (without scuff strip)

THIS SHELTER PAINTED WITH CARC PAINT			
	PAINT TYPE	MIL SPEC COLOR	COLOR CODE FED-STD-595
INTERIOR PAINT	EPOXY	MIL-C-22750 WHITE	17925
EXTERIOR PAINT	ALIPHATIC POLYURETHANE	MIL-C-46168 GREEN 383 BROWN 383 BLACK	34094 30051 37030
PRIMER	EPOXY	MIL-P-53022	
FLOOR PAINT	WALKWAY COMPOUND	MIL-W-5044 TYPE I GRAY	26251

4-44. (cont)

Green Paint Data Plate (with scuff strip)

THIS SHELTER PAINTED WITH CARC PAINT			
	PAINT TYPE	MIL SPEC COLOR	COLOR CODE FED-STD-595
INTERIOR PAINT	EPOXY	MIL-C-22750 WHITE	17925
EXTERIOR PAINT	ALIPHATIC POLYURETHANE	MIL-C-46166 GREEN 383	34094
PRIMER	EPOXY	MIL-P-53022	
FLOOR PAINT.	WALKWAY COMPOUND	MIL-W-5044 TYPE I GRAY	26251
FLOOR PAINT	WALKWAY COMPOUND	MIL-W-5044 TYPE II GRAY	26251

Green Paint Data Plate (without scuff strip)

THIS SHELTER PAINTED WITH CARC PAINT			
	PAINT TYPE	MIL SPEC COLOR	COLOR CODE FED-STD-595
INTERIOR PAINT	EPOXY	MIL-C-22750 WHITE	17925
EXTERIOR PAINT	ALIPHATIC POLYURETHANE	MIL-C-46168 GREEN 383	34094
PRIMER	EPOXY	MIL-P-53022 TYPE I	
FLOOR PAINT	WALKWAY COMPOUND	MIL-W-5044 TYPE I GRAY	26251

4-43. (cont)

NOTE

Paint data is also listed on color code identification plate on personnel endwall.

- a. Prepare surface for painting by removing all corrosion by wire brushing, sanding, or application of corrosion-removing compounds.
- b. Chemically treat all aluminum parts in accordance with MIL-C-5541, Class 1A.
- c. Areas to be painted shall be free of dust, residue, and cleaning compounds before refinishing.
- d. Solvent, primer, or paint shall not be applied to seals or non-metal parts. Mask such parts with masking tape for protection.

NOTE

Check paint data plate for primer used.

- e. Mix and apply epoxy primer coating in accordance with MIL-P-53022 or MIL-P-23377.
- f. Allow to dry thoroughly before applying finish coat.
- g. Mix and apply paint in accordance with manufacturers instructions.
- h. Apply two separate, uniform coats. Make sure there are no sags or runs.
- i. Allow first coat to dry before applying second coat-

4-44. DECAL REMOVAL AND REPLACEMENT

- a. Use a putty knife (or similar tool) to peel decals off all surfaces.
- b. Clean all decal mounting surfaces.
- c. Apply sealing compound, Item 19, Appendix E, to the rear of decals and position on mounting surfaces.

4-45. ELECTRICAL SYSTEM SCHEMATIC DIAGRAM - 60 AMP (CIRCUIT BREAKER PANEL NO.0B)

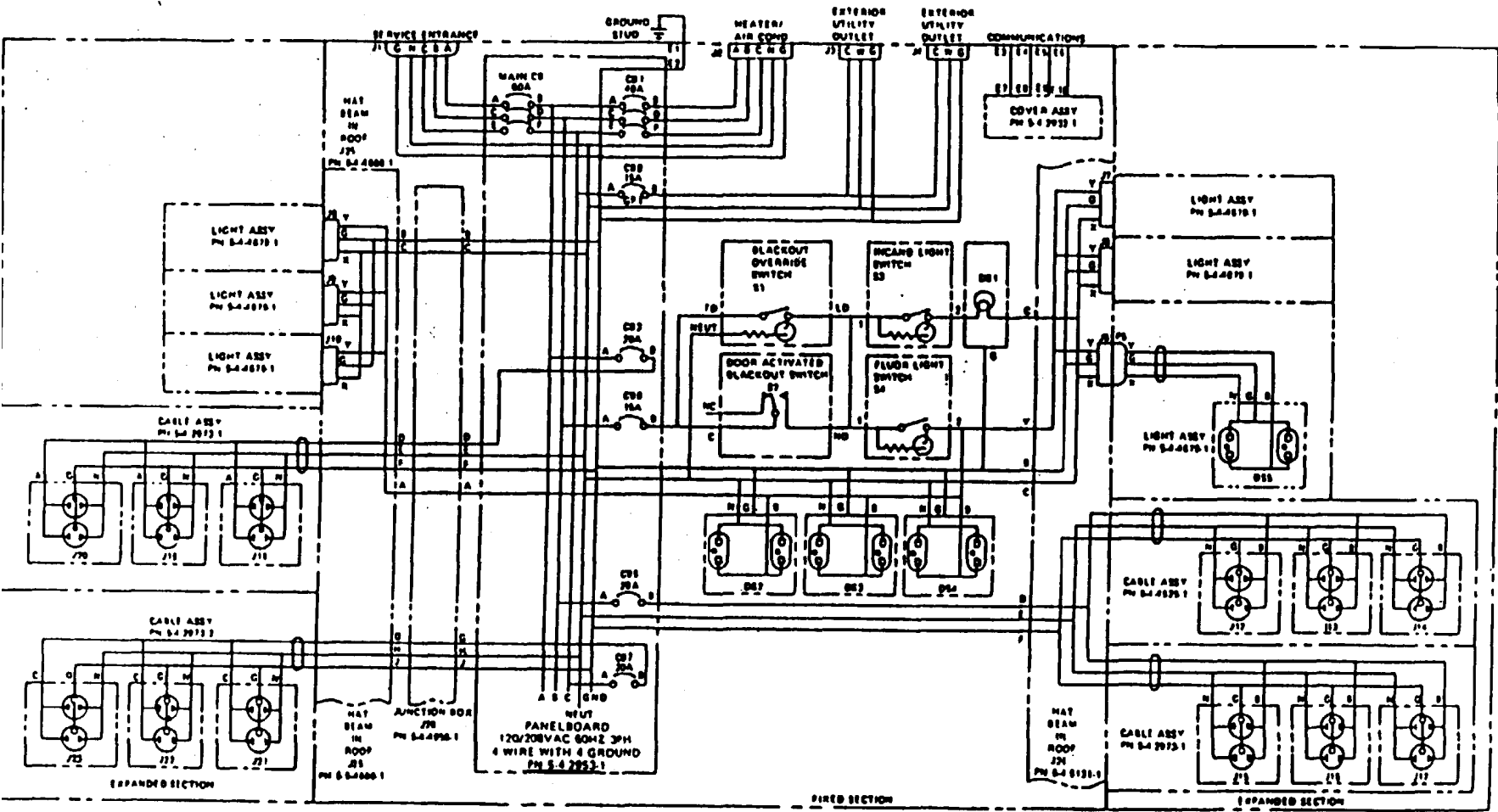

4-45A. ELECTRICAL SYSTEM SCHEMATIC DIAGRAM - 60 AMP (CIRCUIT BREAKER PANEL NG0D)

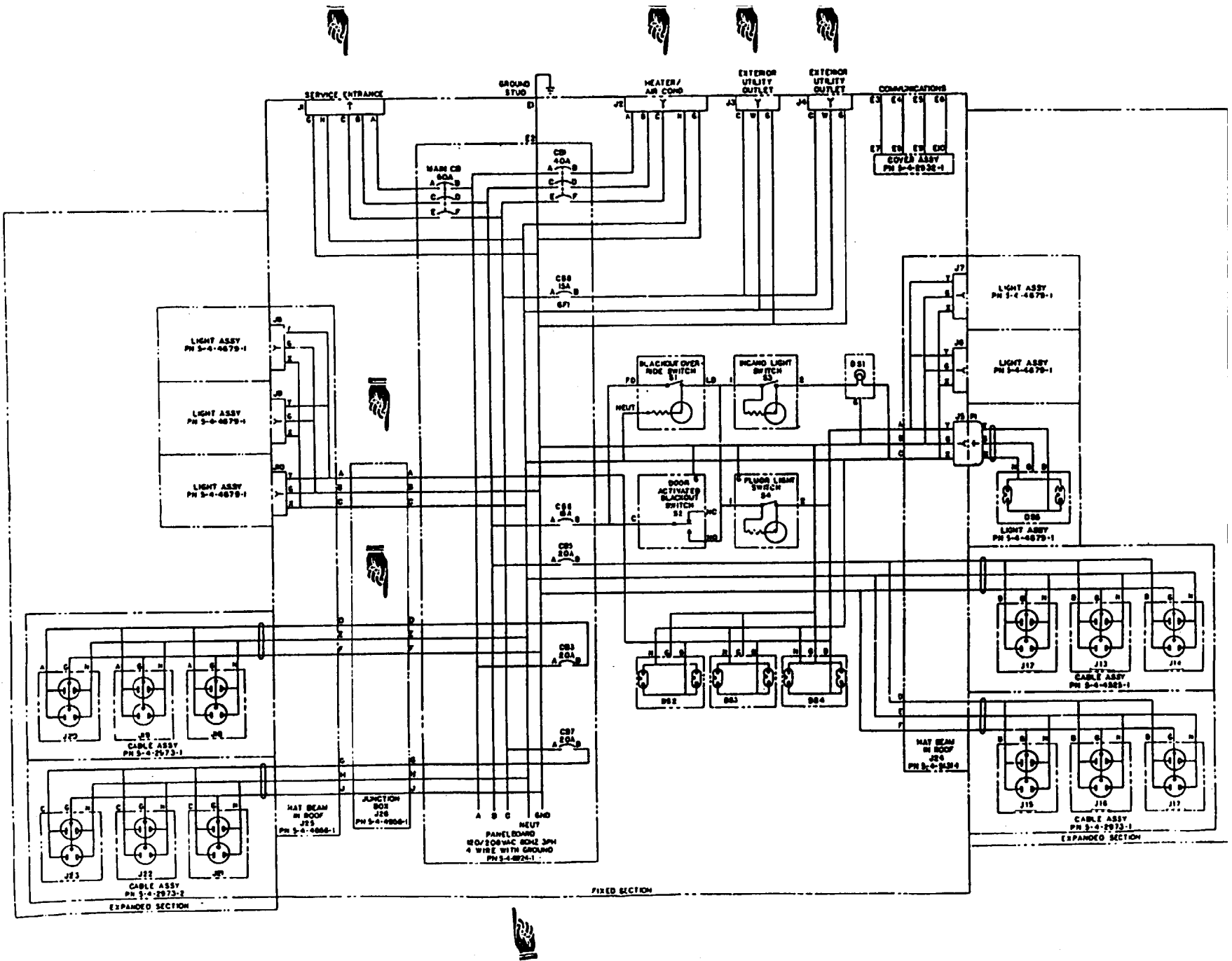

CHANGE 8 4-182.1/(4-182.2 blank)

4-46. HIRE LIST FOR 60 ANP SERVICE

Wire No	Inch Long	Size Awg And Color	From	To
W1-1	8	12 RED	CB6-B	S1-FD
W1-2	165	12 RED	CB6-B	S2-C
W1-3	8	12 RED	S1-LD	S3-1
W1-4	165	12 RED	S2-NO	S1-LD
W1-5	33	12 RED	S2-NO	S4-1
W1-6	150	12 RED	S3-2	DS1
W1-7	65	12 RED	S4-2	J26-A
W1-8	50	12 RED	J26-A	J25-A
W1-9	17	12 RED	J25-A	J8-Y
W1-10	86	12 RED	J25-A	J9-Y
W1-11	158	12 RED	J25-A	J10-Y
W1-12	88	12 RED	J26-A	J24-A
W1-13	20	12 RED	J24-A	J7-Y
W1-14	90	12 RED	J24-A	J6-Y
W1-15	162	12 RED	J24-A	J5-Y
W1-16	53	12 RED	J24-A	DS2-B
W1-17	102	12 RED	DS2-B	DS3-B
W1-18	102	12 RED	DS3-B	DS4-B
W1-19	130	12 WHT	J26-C	NEUT
W1-20	88	12 WHT	J26-C	J24-C
W1-21	20	12 WHT	J24-C	J7-X
W1-22	90	12 WHT	J24-C	J6-X
W1-23	162	12 WHT	J24-C	J5-X
W1-24	53	12 WHT	J24-C	DS2-N
W1-25	102	12 WHT	DS2-N	DS3-N
W1-26	102	12 WHT	DS3-N	DS4-N
W1-27	50	12 WHT	J26-C	J25-C
W1-28	17	12 WHT	J25-C	J8-X
W1-29	86	12 WHT	J25-C	J9-X
W1-30	158	12 WHT	J25-C	J10-X
W1-31	27	12 WHT	J26-C	DS1
W1-32	130	12 GRN	J26-B	GND
W1-33	88	12 GRN	J26-B	J24-B
W1-34	20	12 GRN	J24-B	J7-G
W1-35	90	12 GRN	J24-B	J6-G
W1-36	162	12 GRN	J24-B	J5-G
W1-37	53	12 GRN	J24-B	DS2-G
W1-38	102	12 GRN	DS2-G	DS3-G
W1-39	102	12 GRN	DS3-G	DS4-G
W1-40	50	12 GRN	J26-B	J25-B
W1-41	17	12 GRN	J25-B	J8-G
W1-42	86	12 GRN	J25-B	J9-G
W1-43	158	12 GRN	J25-B	J10-G
W1-44	26	12 BLK	P1-Y	DS5-B
W1-45	26	12 WHT	P1-X	DS5-N
W1-46	26	12 GRN	PA-G	DS5-G

4-46. (cOnt)

Wire No	Inch Long	Size Awg And Color	From	To
W1-47	20	12 BLU	CB8-B	J3-C
W1-48	20	12 BLU	CB8-B	J4-C
W1-49	20	12 WHT	J3-W	NEUT
W1-50	20	12 WHT	J4-W	NEUT
W1-51	20	12 GRN	J3-G	GND
W1-52	20	12 GRN	J4-G	NEUT
W1-53	12	12 RED	E3	E7
W1-54	12	12 RED	E4	E8
W1-55	12	12 RED	E5	E9
W1-56	12	12 RED	E6	E10
W1-57	10	12 WHT	S1-NEUT	NEUT
W1-58	27	12 GRN	J26-B	DS1-G
W1-59	10	12 BARE	S2-GND	DS1-BOX GND
W1-60	24	12 BRN	DS1-G	S3-BOX GND
W2-1	130	12 BLK	CB3-B	J26-D
W2-2	38	12 BLK	J26-D	J25-D
W2-3	68	12 BLK	J25-D	J18-A
W2-4	111	12 BLK	J18-A	J19-A
W2-5	61	12 BLK	J19-A	J20-A
W2-6	48	12 BLK	CB5-B	J12-B
W2-7	111	12 BLK	J12-B	J13-B
W2-8	61	12 BLK	J13-B	J14-B
W2-9	42	12 BLK	J24-D	J15-B
W2-10	111	12 BLK	J15-B	J16-B
W2-11	61	12 BLK	J16-B	J17-B
W2-12	42	12 BLK	J26-G	J21-C
W2-13	111	12 BLK	J21-C	J22-C
W2-14	61	12 BLK	J22-C	J23-C
W2-15	250	12 RED	CB5-B	J24-D
W2-16	130	12 BLU	CB7-B	J26-G
W2-17	234	12 BLU	J26-G	J25-G
W2-18	250	12 WHT	J24-E	NEUT
W2-19	130	12 WHT	J26-E	NEUT
W2-20	38	12 WHT	J26-E	J25-E
W2-21	130	12 WHT	J26-H	NEUT
W2-22	234	12 WHT	J26-H	J25-H
W2-23	48	12 WHT	J12-N	NEUT
W2-24	111	12 WHT	J12-N	J13-N
W2-25	61	12 WHT	J13-N	J14-N
W2-26	42	12 WHT	J24-E	J15-N
W2-27	111	12 WHT	J15-N	J16-N
W2-28	61	12 WHT	J16-N	J17-N
W2-29	68	12 WHT	J25-E	J18-N
W2-30	111	12 WHT	J18-N	J19-N
W2-31	61	12 WHT	J19-N	J20-N
W2-32	42	12 WHT	J25-H	J21-N
W2-33	111	12 WHT	J21-N	J22-N

4-46. (cont)

Wire No	Inch Long	Size Awg And Color	from	TO
W2-34	61	12 WHT	J22-N	J23-N
W2-35	6	12 BARE	J12-G	BOX GND
W2-36	6	12 BARE	J13-G	BOX GND
W2-37	6	12 BARE	J14-G	BOX GND
W2-38	250	12 GRN	J24-F	GND
W2-39	5	12 BARE	J15-G	BOX GND
W2-40	5	12 BARE	J16-G	BOX GND
W2-41	6	12 BARE	J17-G	BOX GND
W2-42	130	12 GRN	J26-J	GND
W2-43	38	12 GRN	J26-F	J25-F
W2-44	6	12 BARE	J18-G	BOX GND
W2-45	6	12 BARE	J19-G	BOX GND
W2-46	6	12 BARE	J20-G	BOX GND
W2-47	234	12 GRN	J26-J	J25-J
W2-48	6	12 BARE	J21-G	BOX GND
W2-49	6	12 BARE	J22-G	BOX GND
W2-50	6	12 BARE	J23-G	BOX GND
W2-51	48	12 GRN	J12-G	GND
W2-52	111	12 GRN	J12-G	J13-G
W2-53	61	12 GRN	J13-G	J14-G
W2-54	42	12 GRN	J24-F	J15-G
W2-55	111	12 GRN	J15-G	J16-G
W2-56	61	12 GRN	J16-G	J17-6
W2-57	68	12 GRN	J25-F	J18-G
W2-58	111	12 GRN	J18-G	J10-G
W2-59	61	12 GRN	J19-G	J20-6
W2-60	42	12 GRN	J25-J	J21-6
W2-61	111	12 GRN	J21-G	322-6
W2-62	61	12 GRN	J22-G	323-G
W2-63	117	12 GRN	J26-F	GND
W3-1	36	4 BLK	J1-A	MAIN CB-A
W3-2	36	4 RED	J1-B	MAIN CB-C
W3-3	36	4 BLU	J1-C	MAIN CB-E
W3-4	36	4 WHT	J1-N	NEUT
W3-5	36	6 GRN	J1-G	GND
W3-6	36	6 GRN	E1	E2
W4-1	36	4 BLK	J2-A	CB1-B
W4-2	36	4 RED	J2-B	CB1-D
W4-3	36	4 BLU	J2-C	CB1-F
W4-4	36	4 WHT	J2-N	NEUT
W4-5	36	6 GRN	J2-G	GND

4-47. ELECTRICAL SYSTEM SCHEMATIC DIAGRAM - 100 AMP (CIRCUIT BREAKER PANEL NOOB)

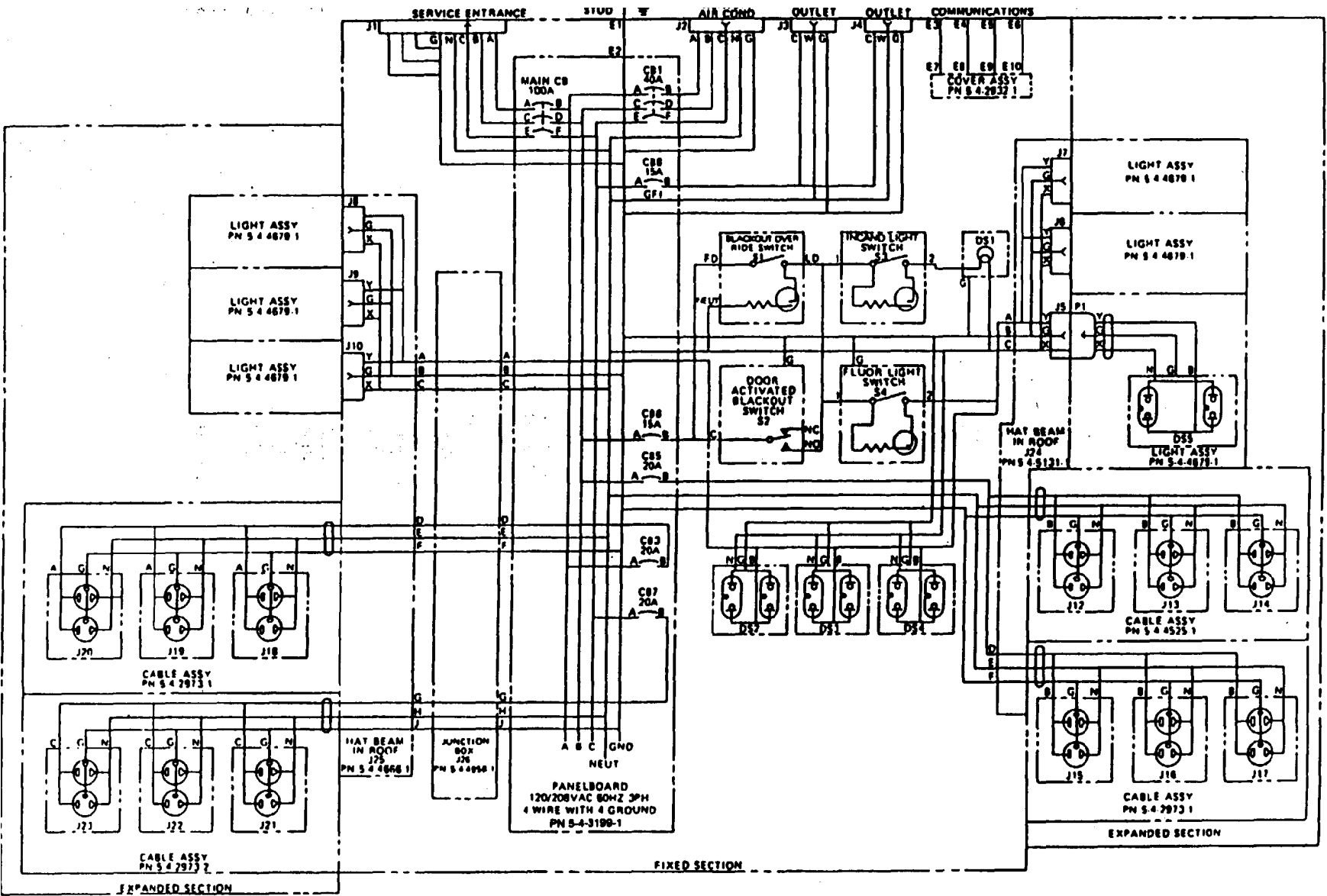

4-48. WIRE LIST FOR 100 AMP SERVICE

Wire No	Inch Long	Size Awg And Color	From	To
W1-1	8	12 RED	CB6-B	S1-FD
W1-2	165	12 RED	CB6-B	S2-C
W1-3	8	12 RED	S1-LD	S3-1
W1-4	165	12 RED	S2-NO	S1-LD
W1-5	42	12 RED	S2-NO	S4-1
W1-6	150	12 RED	S3-2	DS1
W1-7	60	12 RED	S4-2	J26-A
W1-8	50	12 RED	J26-A	J25-A
W1-9	17	12 RED	J25-A	J8-Y
W1-10	86	12 RED	J25-A	J9-Y
W1-11	158	12 RED	J25-A	J10-Y
W1-12	88	12 RED	J26-A	J24-A
W1-13	20	12 RED	J24-A	J7-Y
W1-14	90	12 RED	J24-A	J6-Y
W1-15	162	12 RED	J24-A	J5-Y
W1-16	53	12 RED	J24-A	DS2-B
W1-17	102	12 RED	DS2-B	DS3-B
W1-18	102	12 RED	DS3-B	DS4-B
W1-19	130	12 WHT	J26-C	NEUT
W1-20	88	12 WHT	J26-C	J24-C
W1-21	20	12 WHT	J24-C	J7-X
W1-22	90	12 WHT	J24-C	J6-X
W1-23	162	12 WHT	J24-C	J5-X
W1-24	53	12 WHT	J24-C	DS2-N
W1-25	102	12 WHT	DS2-N	DS3-N
W1-26	102	12 WHT	DS3-N	DS4-N
W1-27	50	12 WHT	J26-C	J25-C
W1-28	17	12 WHT	J25-C	J8-X
W1-29	86	12 WHT	J25-C	J9-X
W1-30	158	12 WHT	J25-C	J10-X
W1-31	36	12 WHT	J26-C	DS1
W1-32	130	12 GRN	J26-B	GND
W1-33	88	12 GRN	J26-B	J24-B
W1-34	20	12 GRN	J24-B	J7-G
W1-35	90	12 GRN	J24-B	J6-G
W1-36	162	12 GRN	J24-B	J5-G
W1-37	53	12 GRN	J24-B	DS2-G
W1-38	102	12 GRN	DS2-G	DS3-G
W1-39	102	12 GRN	DS3-G	DS4-G
W1-40	50	12 GRN	J26-B	J25-B
W1-41	17	12 GRN	J25-B	J8-G
W1-42	86	12 GRN	J25-B	J9-G
W1-43	158	12 GRN	J25-B	J10-G
W1-44	24	14 BLK	P1-Y	DS5-B
W1-45	24	14 WHT	P1-X	DS5-N
W1-46	24	14 GRN	P1-G	DS5-G
W1-47	20	12 BLU	CB8-B	J3-C
W1-48	20	12 BLU	CB8-B	J4-C

4-48. (cont)

Wire No	Inch Long	Size Awg And Color	From	To
W1-49	20	12 WHT	J3-W	NEUT
W1-50	20	12 WHT	J4-W	NEUT
W1-51	20	12 GRN	J3-G	GND
W1-52	20	12 GRN	J4-G	GND
W1-53	18	12 RED	E3	E7
W1-54	18	12 RED	E4	E8
W1-55	18	12 RED	E5	E9
W1-56	18	12 RED	E6	E10
W1-57	30	12 WHT	S1-NEUT	NEUT
W1-58	30	12 GRN	J26-B	DS1-G
W1-59	10	12 BARE	S2-GND	DS1-BOX GND
W1-60	30	12 GRN	DS1-G	S4-BOX GND
W2-1	130	12 BLK	CB3-B	J26-D
W2-2	38	12 BLK	J26-D	J25-D
W2-3	68	12 BLK	J25-D	J18-A
W2-4	111	12 BLK	J18-A	J19-A
W2-5	61	12 BLK	J19-A	J20-A
W2-6	48	12 BLK	CB5-B	J12-B
W2-7	111	12 BLK	J12-B	J13-B
W2-8	61	12 BLK	J13-B	J14-B
W2-9	42	12 BLK	J24-D	J15-B
W2-10	111	12 BLK	J15-B	J16-B
W2-11	61	12 BLK	J16-B	J17-B
W2-12	42	12 BLK	J25-G	J21-C
W2-13	111	12 BLK	J21-C	J22-C
W2-14	61	12 BLK	J22-C	J23-C
W2-15	250	12 RED	CB5-B	J24-D
W2-16	130	12 BLU	CB7-B	J26-G
W2-17	234	12 BLU	J26-G	J25-G
W2-18	250	12 WHT	J24-E	NEUT
W2-19	130	12 WHT	J26-E	NEUT
W2-20	38	12 WHT	J26-E	J25-E
W2-21	130	12 WHT	J26-H	NEUT
W2-22	234	12 WHT	J26-H	J25-H
W2-23	48	12 WHT	J12-N	NEUT
W2-24	111	12 WHT	J12-N	J13-N
W2-25	61	12 WHT	J13-N	J14-N
W2-26	42	12 WHT	J24-E	J15-N
W2-27	111	12 WHT	J15-N	J16-N
W2-28	61	12 WHT	J16-N	J17-N
W2-29	68	12 WHT	J25-E	J18-N
W2-30	111	12 WHT	J18-N	J19-N
W2-31	61	12 WHT	J19-N	J20-N
W2-32	42	12 WHT	J25-H	J21-N
W2-33	111	12 WHT	J21-N	J22-N
W2-34	61	12 WHT	J22-N	J23-N
W2-35	6	12 BARE	J12-G	BOX GND
W2-36	6	12 BARE	J13-G	BOX GND

4-48. (cont)

Wire No	Inch Long	Size Awg And Color	From	To
W2-37	6	12 BARE	J14-G	BOX GND
W2-38	250	12 GRN	J24-F	GND
W2-39	6	12 BARE	J15-G	BOX GND
W2-40	6	12 BARE	J16-G	BOX GND
W2-41	6	12 BARE	J17-G	BOX GND
W2-42	130	12 GRN	J26-J	GND
W2-43	38	12 GRN	J26-F	J25-F
W2-44	6	12 BARE	J18-G	BOX GND
W2-45	6	12 BARE	J19-G	BOX GND
W2-46	6	12 BARE	J20-G	BOX GND
W2-47	234	12 GRN	J26-J	J25-J
W2-48	6	12 BARE	J21-G	BOX GND
W2-49	6	12 BARE	J22-G	BOX GND
W2-50	6	12 BARE	J23-G	BOX GND
W2-51	48	12 GRN	J12-G	GND
W2-52	111	12 GRN	J12-G	J13-G
W2-53	61	12 GRN	J13-G	J14-G
W2-54	42	12 GRN	J24-F	J15-G
W2-55	111	12 GRN	J15-G	J16-G
W2-56	61	12 GRN	J16-G	J17-G
W2-57	68	12 GRN	J25-F	J18-G
W2-58	111	12 GRN	J18-G	J19-G
W2-59	61	12 GRN	J19-G	J20-G
W2-60	42	12 GRN	J25-J	J21-G
W2-61	111	12 GRN	J21-G	J22-G
W2-62	61	12 GRN	J22-G	J23-G
W2-63	130	12 GRN	J26-F	GND
W3-1	36	2 BLK	J1-A	MAIN CB-A
W3-2	36	2 RED	J1-B	MAIN CB-C
W3-3	36	2 BLU	J1-C	MAIN CB-E
W3-4	52	2 WHT	J1-N	NEUT
W3-5	36	6 GRN	J1-G1	GND
W3-6	36	6 GRN	J1-G2	GND
W3-7	36	6 GRN	J1-G3	GND
W3-8	36	6 GRN	J1-G4	GND
W3-9	36	6 GRN	E1	E2
W4-1	36	4 BLK	J2-A	CB1-B
W4-2	36	4 RED	J2-B	CB1-D
W4-3	36	4 BLU	J2-C	CB1-F
W4-4	52	4 WHT	J2-N	NEUT
W4-5	36	6 GRN	J2-G	GND

Section IV. PREPARATION FOR STORAGE AND SHIPMENT

4-49. PREPARATION FOR STORAGE AND SHIPMENT. The following steps describe procedures for storing or shipping the shelter.

a. Inspection. Inspect the shelter for the following:

- (1) Make sure all circuit breakers and switches in OFF position.
- (2) Make sure circuit breaker panel door is closed.
- (3) Make sure equipment container is strapped down to shelter floor.
- (4) Make sure caps are secured on power entry panel receptacles and binding posts are tightened.
- (5) Make sure the stop plate in the load balancer is in the down position and secured with the pin.
- (6) Make sure all lights and jacks are secured in their stowage positions.
- (7) Make sure the foot bolt and chain bolt are secured.
- (8) Make sure the receptacle outlets are stowed and the roof struts are secured.
- (9) Make sure all doors are securely closed.
- (10) Make sure camlock pin is engaged in hole or corner post.

b. Packing. Be sure all components are clean and dry before packing.

CAUTION

Use care when transporting or storing shelter to prevent damage to shelter.

c. Care and Storage. Store shelter in a dry area or a designated supply facility. If stored outside in humid conditions, check quarterly for dampness inside the shelter.

CHAPTER 5

DIRECT SUPPORT MAINTENANCE INSTRUCTIONS

5-1. GENERAL. This chapter provides maintenance procedures for direct support personnel and consists of the following:

- a. Circuit breaker panel assembly replacement and repair (paragraph 5-2) .
- b. Power entry panel assembly replacement and repair (paragraph 5-3).
- c* Roof panel replacement (paragraph 5-4).

Corner post and ISO fitting assembly replacement and repair (paragraph 5-5).

5-2. CIRCUIT BREAKER PANEL ASSEMBLY REPLACEMENT AND REPAIR

This task covers:

- a. Removal
- b. Disassembly
- c. Cleaning, Inspection
- d. Repair
- e. Assembly
- f. Installation

INITIAL SETUP

Standard. Tools
General mechanics tool kit

Personnel
Electrician

REMOVAL

- 1. Disconnect site power.
- 2. Set all circuit breakers and switches to OFF position.

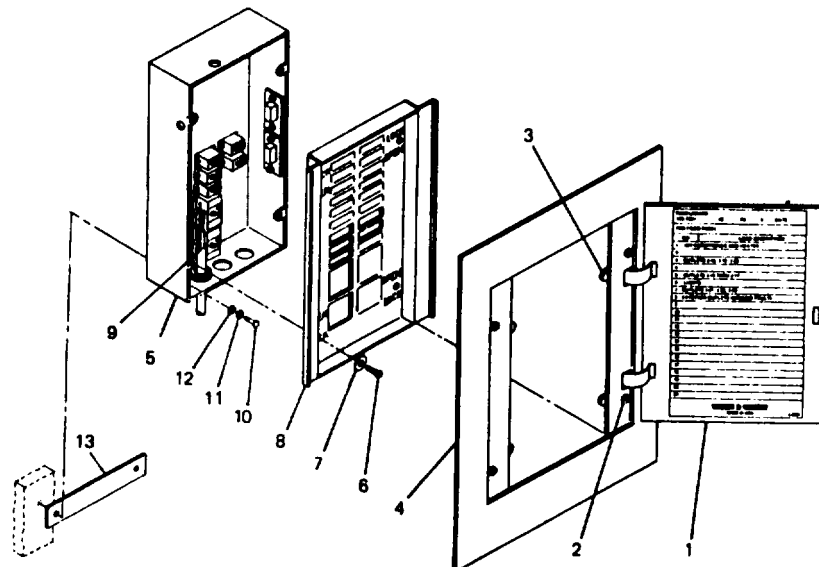

5-2. (cont)

3. Open circuit breaker panel door (1).
4. Loosen four captive screws (2) and move four clamp fingers (3) to OPEN position.
5. Lift circuit breaker panel cover (4) from circuit breaker box (5).
6. Remove four screws (6) and washers (7) and lift panelboard (8) from circuit breaker box (5).

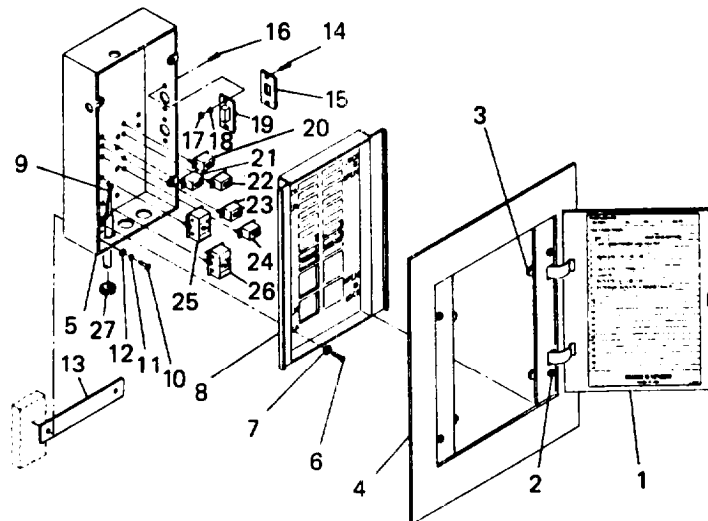

7. Disconnect wires (9) from circuit breakers and switches.

NOTE

Tag all wires for reconnection.

8. Remove screws (10), lockwashers (11), and washers (12), and separate circuit breaker panel assembly (5) and spacer (13) from personnel door end wall panel.

DISASSEMBLY

1. Open circuit breaker panel door (1).
2. Loosen four captive screws (2) and move four clamp fingers (3) to OPEN position.
3. Lift circuit breaker panel cover (4) from circuit breaker box (5).
4. Remove four screws (6) and washers (7) and lift panelboard (8) from circuit breaker box (5).
5. Disconnect wires (9) from light switches (19) and circuit breakers (20 through 26).

5-2. (cont)

NOTE

Tag all wires for reconnection.

6. Remove four screws (14) and two switch covers (15).
7. Remove four screws (16), nuts (17), and lockwashers (18), and remove two light switches (19) from circuit breaker box (5).
8. Remove circuit breakers (20 through 26) from circuit breaker box (5).
9. Remove grommets (27) from circuit breaker box (5).

CLEANING, INSPECTION

1. Clean circuit breaker panel and components surfaces:
2. Inspect mounting surfaces for corrosion and damage.
3. Inspect for and replace if necessary:
 - a. Missing or damaged components
 - b. Corrosion or paint damage.

REPAIR

Repair corrosion or paint damage. (Refer to paragraph 4-43)

ASSEMBLY

1. Install grommets (27) in circuit breaker box (5).
2. Install circuit breakers (20 through 26) in circuit breaker box (5).
3. Connect wires (9) to circuit breakers (20 through 26). (Refer to paragraph 4-46)
4. Position two light switches (19) in circuit breaker box (5) and secure with four screws (16), nuts (17), and lockwashers (18).
5. Position two switch covers (15) over light switches (19) and secure with four screws (14).
6. Connect wires (9) to light switches (19). (Refer to paragraph 4-46)
7. Position panelboard (8) over circuit breakers (20 through 26) in circuit breaker box (5) and secure with four screws (6) and washers (7).

5-2. (cont)

8. Position circuit breaker panel cover (4) against circuit breaker box (5) and secure by moving four clamp fingers (3) to LOCK position and tightening four captive screws (2).

Close circuit breaker panel door (1).

INSTALLATION

1. Position spacer (13) and circuit breaker panel box (5) against personnel door end wall panel and secure with screws (10), lockwashers (11), and washers (12),
2. Connect wires (9) to light switches and circuit breakers. (Refer to paragraph 4-46)
3. Position panelboard (8) over circuit breakers in circuit breaker box (5) and secure with four screws (6) and washers (7).
4. Position circuit breaker panel cover (4) against circuit breaker box (5) and secure by moving four clamp fingers (3) to lock position and tightening four captive screws (2).
5. Close circuit breaker panel door (1).

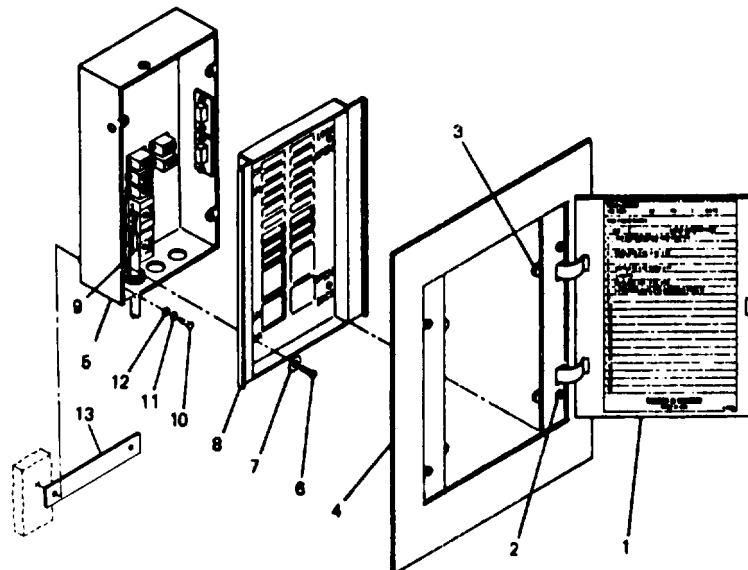

5-3. POWER ENTRY PANEL ASSEMBLY REPLACEMENT AND REPAIR

This task covers:

- | | |
|-------------------------|-----------------|
| a. Removal | d. Repair |
| b. Disassembly | e. Assembly |
| c. Cleaning, Inspection | f. Installation |
-

INITIAL SETUP

Special Tools

Hand blind riveter, Appendix B, Item 2
Crimping tool, Appendix B, Item 12

Standard Tools

General mechanics tool kit

Personnel

Electrician

WARNING

Disconnect all power sources from power entry panel assembly before removing.

REMOVAL

1. Inside shelter, remove screws (1), lockwashers (2), and washers (3), and carefully lift cover assembly (4) away from personnel door end wall panel as far as it will go,
2. Disconnect wires at receptacles and terminals/connectors from back of power entry panel assembly (5).

NOTE

Tag all wires for reconnection.

3. Outside shelter, drill out rivets (6) and remove power entry panel assembly (5) from personnel door end wall panel. (Refer to paragraph 4-32)

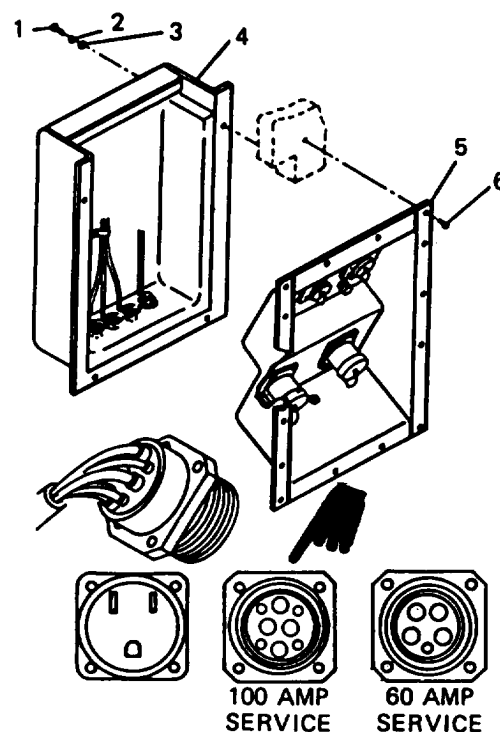

5-3. (cont)

DISASSEMBLY

1. Remove screws (1), lockwashers (2), receptacle covers (3), and nuts (4).
2. Remove receptacles (5 and 6) and gaskets (7) from panel (8).
3. Remove screws (9), lockwashers (10), receptacle covers (11), nuts (12), and washers (23).
4. Remove receptacles (13 and 14) from panel (8).
5. Remove rubber cap (15), nut (16), lockwasher (17) brass washer (24), nylon washer (25), two O-rings (26), nylon washer (27), and binding post body (28) from panel (8).
6. Remove four nuts (18), three lockwashers (19), three washers (20), terminal lug (21), and threaded stud (22) from panel (8).

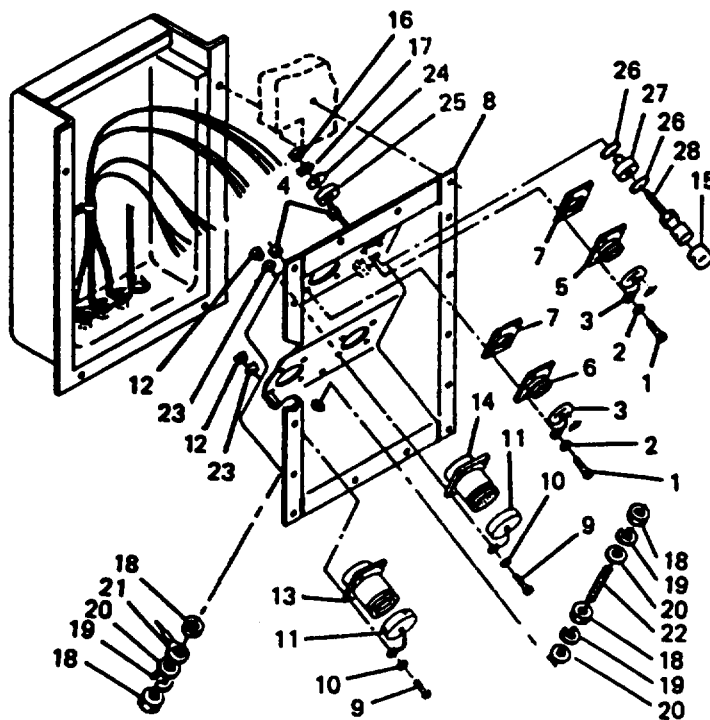

CLEANING, INSPECTION

1. Clean power entry panel and component surfaces.
2. Inspect mounting surfaces for corrosion and damage.

5-3. (cont)

3. Inspect for and replace if necessary:
 - a. Hissing or damaged components.
 - b. Corrosion or paint damage.

REPAIR

Repair corrosion or paint damage. (Refer to paragraph 4-43)

ASSEMBLY

1. Install threaded stud (22), terminal lug (21), three washers (20), three lockwashers (19), and four nuts (18) in panel (8).
2. Install binding post body (28), nylon washer (27), two O-rings (26), nylon washer (25), brass washer (24), lockwasher (17), nut (16), and rubber cap (15) in panel (8).
3. Using crimping tool, attach wires to receptacle pins. (Refer to paragraph 4-46).
4. Install receptacles (13 and 14) in panel (8) and secure with screws (9), lockwashers (10), receptacle covers (11), washers (23), and nuts (12).
5. Install receptacles (5 and 6) and gaskets (7) in panel (8) and secure with screws (1), lockwashers (2), receptacle covers (3), and nuts (4),

INSTALLATION

1. Position power entry panel assembly (5) against outside-of personnel door end wall panel and secure with rivets (6). (Refer to paragraph 4-32))
2. Connect wires to receptacles and terminals/connectors at rear of power entry panel assembly (5). (Refer to paragraph 4-46)
3. Position cover assembly against inside of personnel door end wall panel and secure with screws (1), lockwashers (2), and washers (3).
4. Reconnect electrical power to service entrance receptacle.

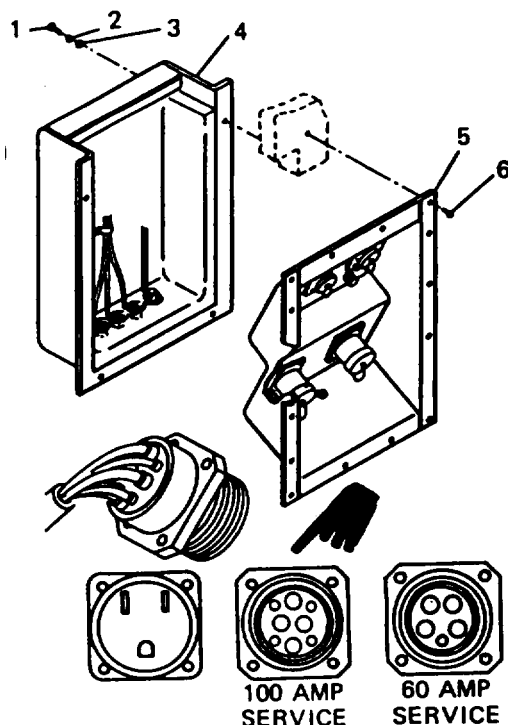

5-4. ROOF PANEL REPLACEMENT

This task covers

- a.
- b. Installation

INITIAL SETUP

Special Tools

Top lifting container lift sling,
Appendix D

Standard Tools

General mechanics tool kit

Personnel - 6

1 Electrician

Materials

Sealing compound, Item 19,
Appendix E

Solvent, Item 20, Appendix E

REMOVAL

1. Disconnect site power.
2. Remove receptacle outlets. (Refer to paragraph 4-13)
3. Set main circuit breaker and circuit breaker CB6 to off position.
4. Remove hinged roof. (Refer to paragraph 4-20)
5. Remove fixed roof area ceiling lights. (Refer to paragraph 4-12)
6. Disconnect and remove all wires from fixed roof beam. Tag all wires for reconnection. (Refer to paragraph 4-16)
7. Remove bolts (1), lockwashers (2), and washers (3) securing fixed roof to upper ISO fittings (4).
8. Remove bolts (5), lockwashers (6), and washers (7) securing fixed roof to fixed personnel endwall and sidewall.
9. Remove bolts (8), lockwashers (9), washers (10) and drip cap (11) securing fixed roof to fixed cargo endwall.

W A R N I N G

Methylethylketone is flammable and toxic and shall be used in well-ventilated area away from sparks or open flame. Gloves should be worn during use.

5-4. (cont)

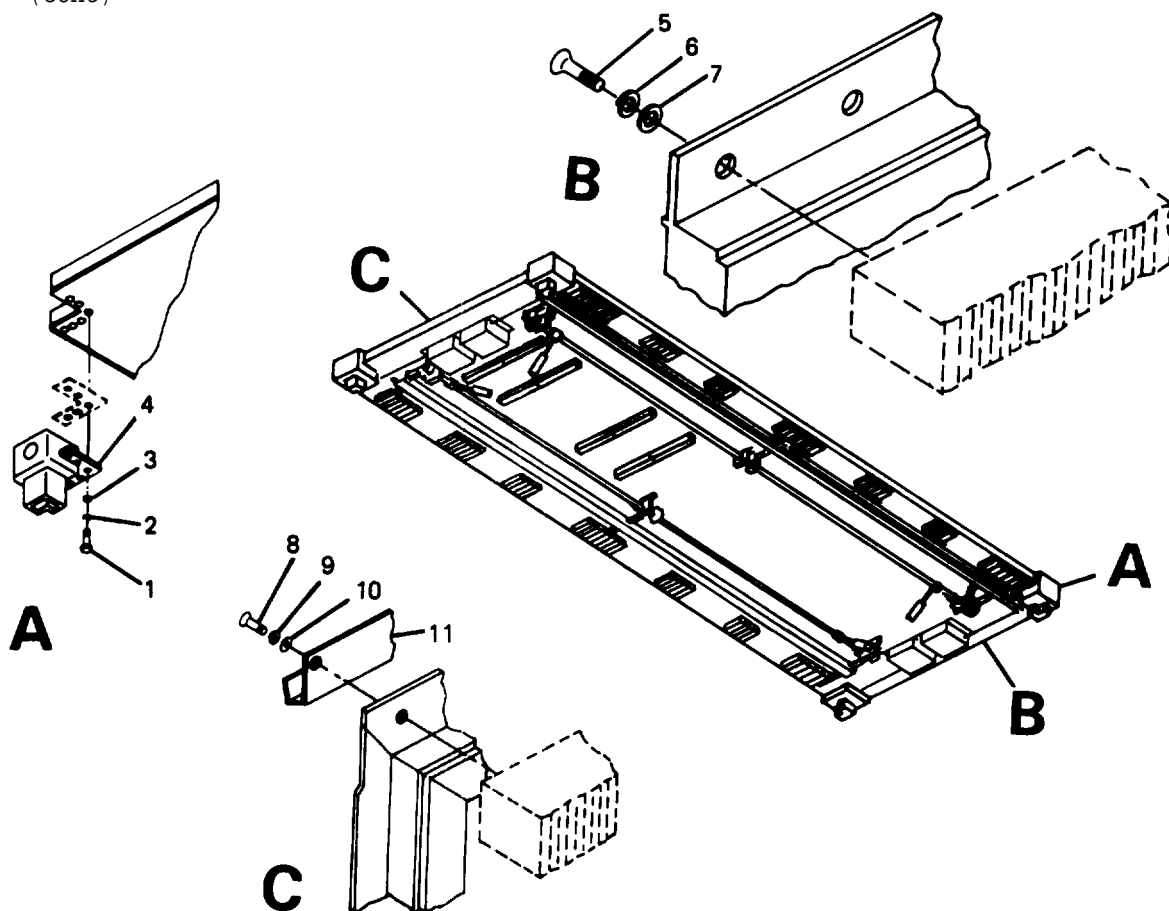

10. Apply solvent to sealed interface areas between roof, sidewall, and endwalls.
11. Push roof up from endwalls to gain clearance for sling. Do not damage roof panel.
12. Slide web straps of lifting sling under roof and attach to crane or equivalent lifting device.
13. Remove fixed roof.

INSTALLATION

1. Apply sealing compound to interface areas of fixed roof with fixed endwalls.
2. Position fixed roof over shelter with crane (or equivalent lifting device) and a lifting sling with web straps.
3. Support fixed roof and remove sling straps to allow roof to be supported by upper ISO fittings at corner posts.
4. Align mounting holes at ISO fittings.

5-4. (cont)

5. Install bolts (1), lockwashers (2), and washers (3) securing fixed roof to upper ISO fittings (4).
6. Install bolts (8), lockwashers (9), washers (10), and drip cap (11) securing fixed roof to fixed cargo endwall.
7. Install bolts (5), lockwashers (6), and washers (7) securing fixed roof to fixed personnel endwall and sidewall.
8. Connect all wires to fixed roof beam. (Refer to paragraph 4-1)
9. Install fixed roof area ceiling lights. (Refer to paragraph 4-12)
10. Install hinged roof area ceiling lights. (Refer to paragraph 3-5)
11. Install receptacle outlets. (Refer to paragraph 4-13)
12. Set all circuit breakers to ON position.

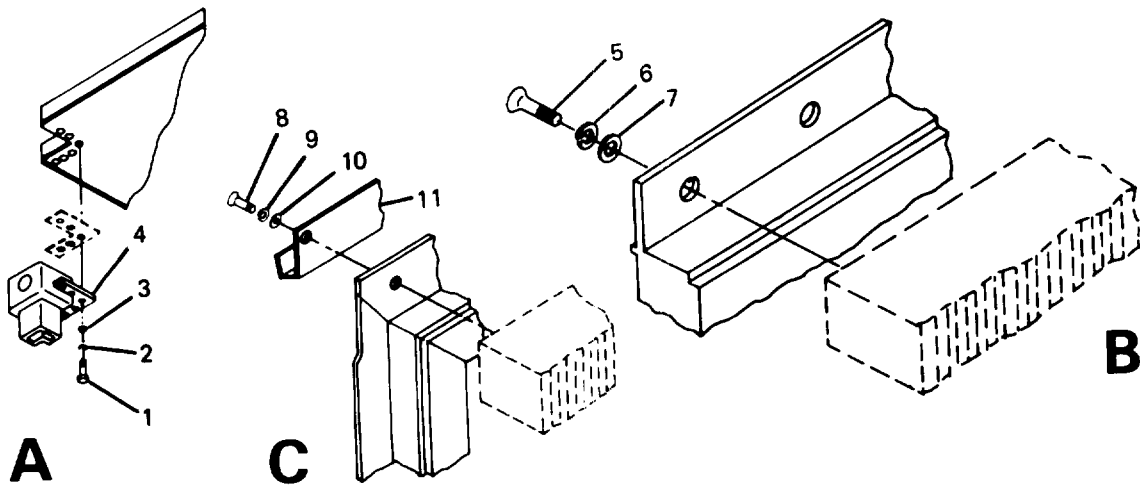

5-5. CORNER POST AND ISO FITTING ASSEMBLY REPLACEMENT AND REPAIR

This task covers:

- | | |
|-------------------------|-----------------|
| a. Removal | d. Repair |
| b. Disassembly | e. Assembly |
| c. Cleaning, Inspection | f. Installation |
-

INITIAL SETUP

Special tools

Hand blind riveter, Appendix B,
Item 2

Standard tools

General mechanics tool kit
Personnel - 2

REMOVAL

NOTE

Remove shelter components as required for individual corner post replacement.

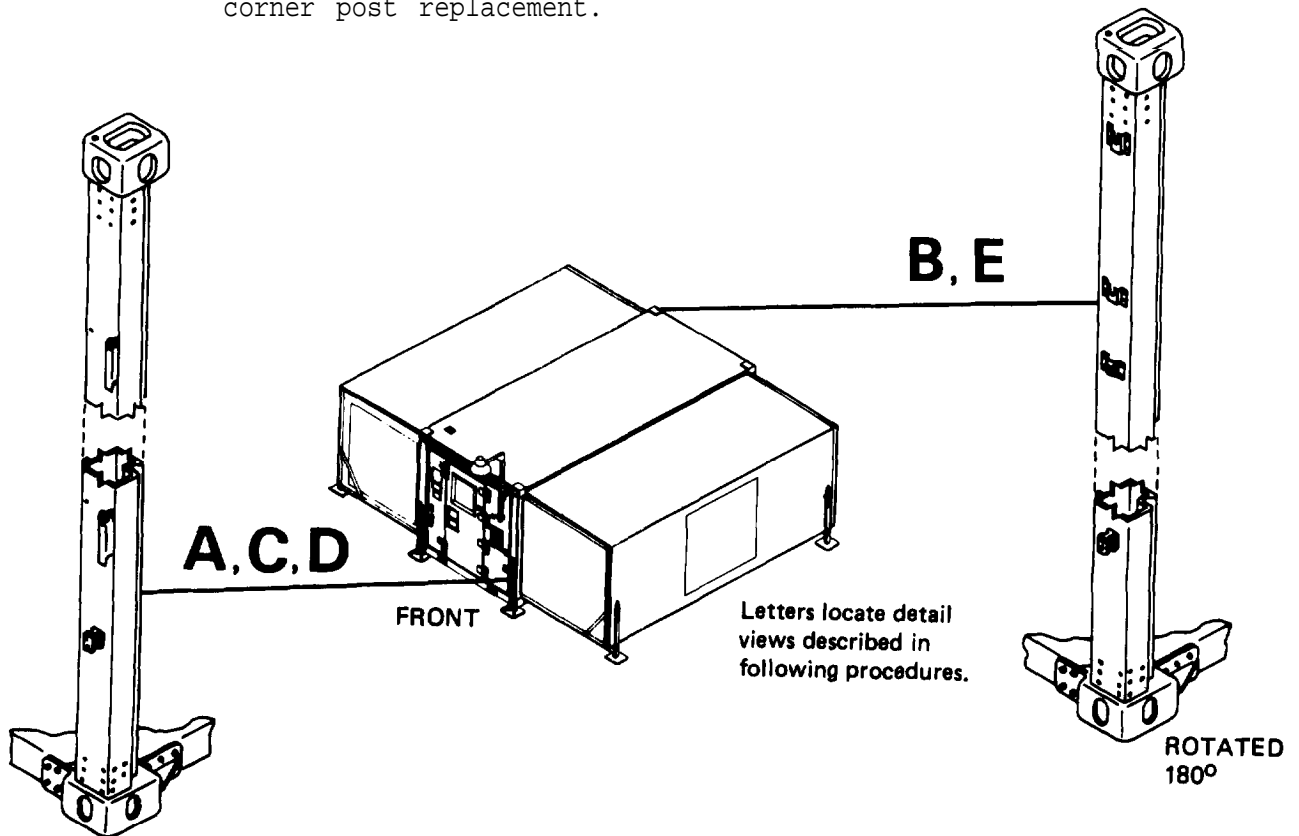

1. Remove hinged sidewalls in accordance with paragraph 4-22.

5-5. (cont)

2. Remove hinged endwalls in accordance with paragraph 4-21.
3. Remove hinged roof panels in accordance with paragraph 4-20.
4. Remove hinged floor panels in accordance with paragraph 4-23.
5. Remove personnel door end endwall panel in accordance with paragraph 4-25.
6. Remove cargo door end endwall panel in accordance with paragraph 4-26.
7. Remove roof panel in accordance with paragraph 5-4.
8. Support corner post (1) and remove bolts (2) securing post to upper and lower ISO fittings (3).

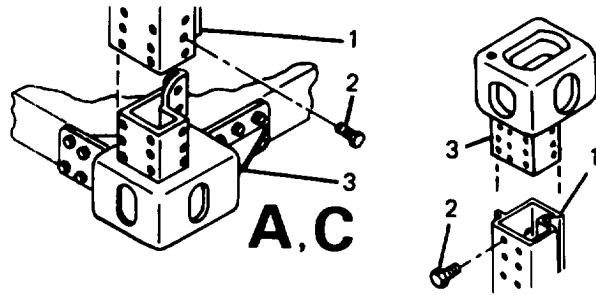

DISASSEMBLY

1. Remove screws (4) and remove jack support fitting (5).
2. Remove cotter pin (6), washer (7), and pin (8) and remove handle (9).
3. Remove washers (10), spring washers (11), and latch cam (12).
4. Remove screws (13) and remove roller assembly (14).
5. Drill out rivets (15) and remove light bracket (16). (Refer to paragraph 4-32)
6. Remove screws (17), lockwashers (18), and washers (19) and remove door holder (20).

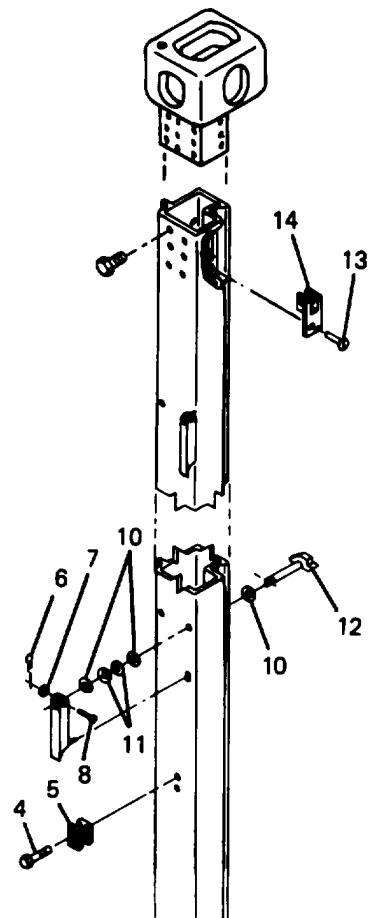

CLEANING, INSPECTION

1. Clean post and component surfaces.
2. Inspect mounting surfaces for corrosion and damage.

5-5. (cont)

3. Inspect for and replace if necessary.
 - a. Missing or damaged components
 - b. Corrosion or paint damage.

REPAIR

Corrosion or paint damage. (Refer to paragraph 4-43)

ASSEMBLY

1. Position door holder (20) and install washers (19), lockwashers (18) and screws (17).
2. Position light bracket (16) and install rivets (15). (Refer to 4-32.)
3. Position roller assembly (14) against corner post and support cable and install screws (13).
4. Position latch cam (12) and install washers (10), spring washers (11), and handle (9).
5. Compress spring washers (11) and install pin (8), washer (7), and cotter pin (6).
6. Position jack support fitting (5) and install screws (4).

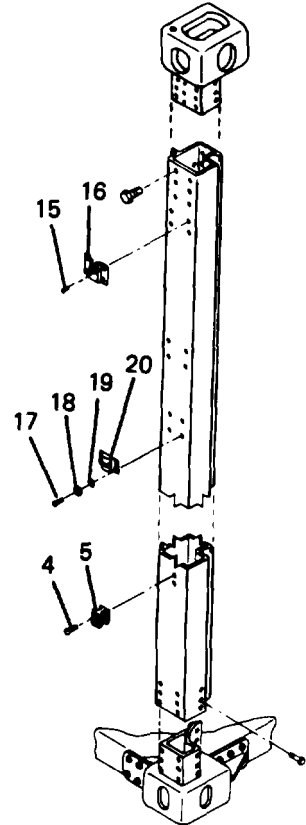

INSTALLATION

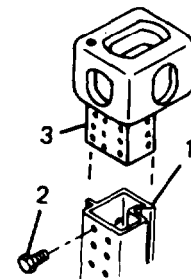
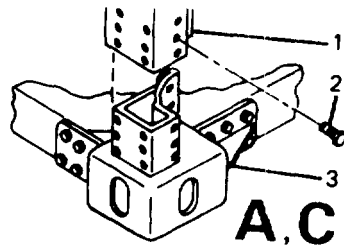

1. Position and support corner post (1) on upper and lower ISO fitting (3) and install bolts (2).
2. Install roof panel in accordance with paragraph 5-4.

5-5. (con)

3. Install cargo door end endwall panel in accordance with paragraph 4-26.
4. Install personnel door end endwall panel in accordance with paragraph 4-25.
5. Install hinged floor panels in accordance with paragraph 4-23.
6. Install hinged roof panels in accordance with paragraph 4-20.
7. Install hinged endwalls in accordance with paragraph 4-21.
8. Remove hinged sidewalls in accordance with paragraph 4-22.

CHAPTER 6

GENERAL SUPPORT MAINTENANCE INSTRUCTIONS

6-1. GENERAL. This chapter consists of maintenance procedures for general support personnel. These procedures are limited to the floor panel replacement (paragraph 6-2).

6-2. FLOOR PANEL REPLACEMENT

This task covers:

- a. Removal
- b. Installation

INITIAL SETUP

Special tools

Hand blind riveter
Lifting sling, Tandemloc No.
No. 74016B-20A
Web straps

Standard Tools

General mechanics tool kit

Personnel - 4

Materials

Solvent, Item 20, Appendix E

References

4-23 Hinged floor panel
replacement and repair

REMOVAL

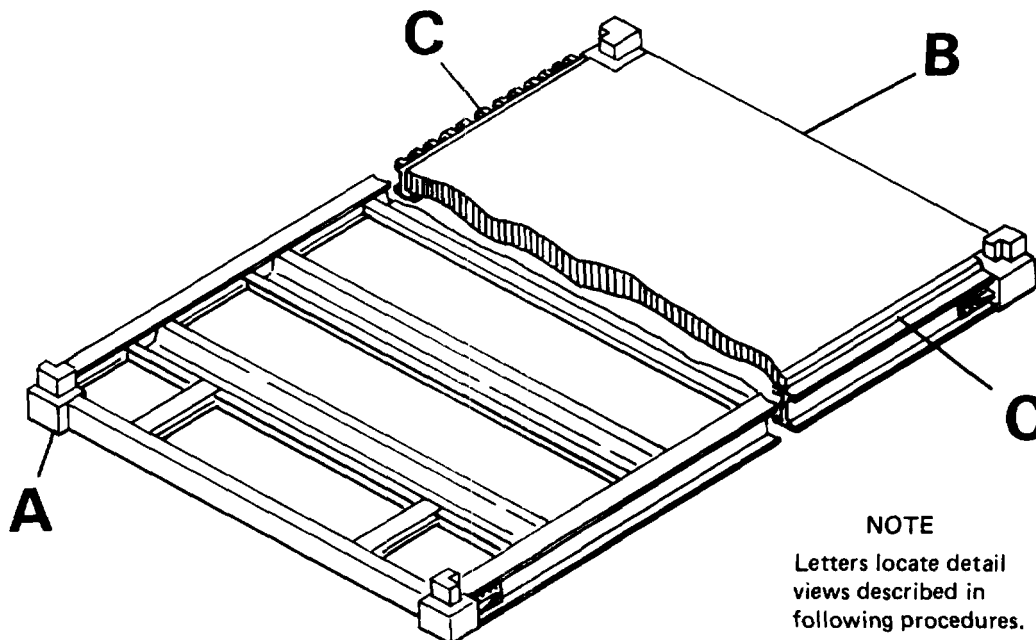

NOTE
Letters locate detail
views described in
following procedures.

6-2. (cont)

1. Remove hinged floor in accordance with paragraph 4-23.
2. Remove bolts (1) securing corner posts (2) to lower ISO fittings (3).
3. Remove bolts (4), lockwashers (5), and washers (6) securing fixed personnel endwall to floor.
4. Remove screws (7), lockwashers (8), and washers (9) securing reinforcement angles (10) to floor.
5. Remove bolts (11), lockwashers (12), and washers (13) securing fixed cargo endwall to floor.
6. Remove screws (14) and lockwashers (15) securing shear plate (16) and shim (17) to floor.

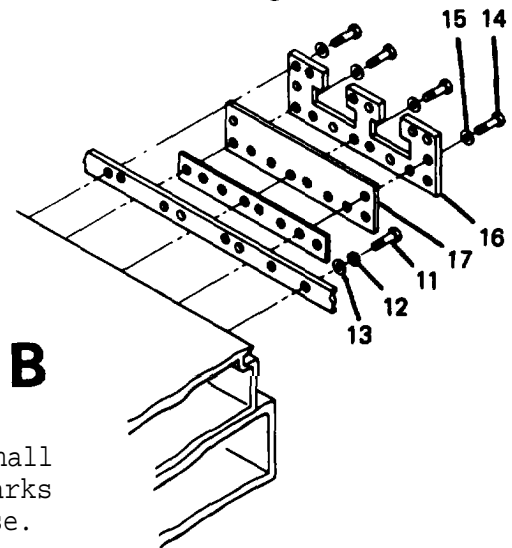
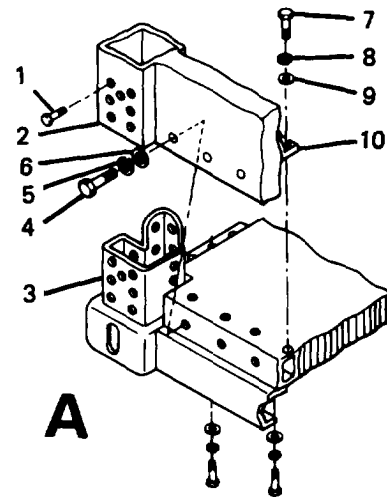

W A R N I N G

Methyle thylketone is flammable and toxic and shall be used in a well-ventilated area away from sparks or open flame. Gloves should be worn during use.

7. Apply solvent to sealed interface areas of floor with fixed sidewall and endwalls.
8. Secure web straps around shelter body.
9. Attach lifting sling to upper ISO fittings.
10. Lift shelter body away from fixed floor and set in level position on blocks.
11. Drill out rivets (18) and remove hinge (19). (Refer to paragraph 4-32)

6-2. (cont)

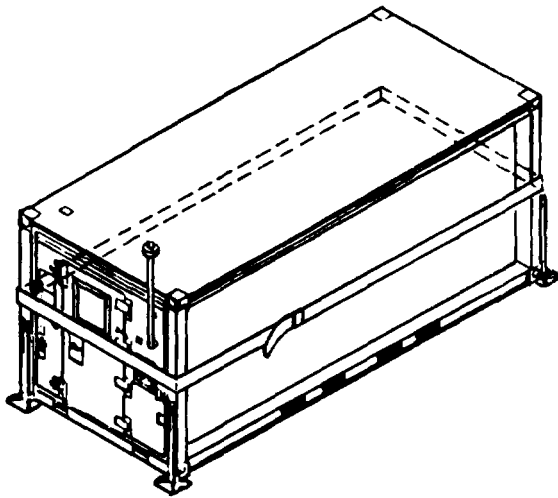

C

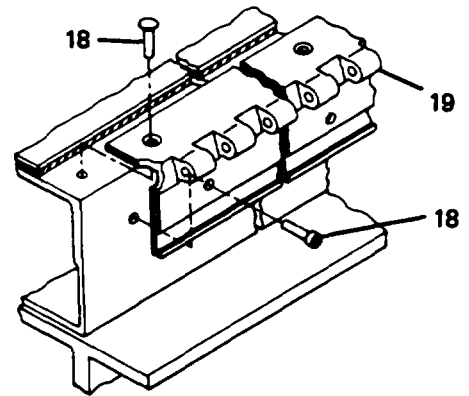

INSTALLATION

NOTE

Turn floor over with base frame down.

1. Position hinge (19) and install rivets (18). (Refer to paragraph 4-32)
2. Secure web straps around shelter body.
3. Attach lifting sling to upper ISO fitting.
4. Lift shelter body and lower to position above fixed floor.
5. Apply sealing compound to interface areas of floor and fixed endwalls.
6. Lower shelter body carefully to fixed floor.
7. Ensure that corner posts engage lower ISO fittings at all four corners.

6-2. (cont)

8. Position shim (17) under plate (16) and install lockwashers (15) and screws (14).
9. Secure fixed cargo endwall to floor with washers (13), lockwashers (12), and bolts (11).
10. Secure fixed personnel endwall to floor with washers (6), lockwashers (5), and bolts (4).
11. Secure reinforcement angles (10) to floor with washers (9), lockwashers (8) and screws (7).
12. Secure corner posts (2) to lower ISO fittings (3) with bolt (1).
13. Install hinged floors in accordance with paragraph 4-23.

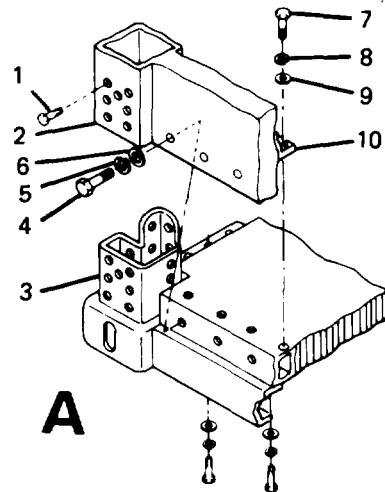
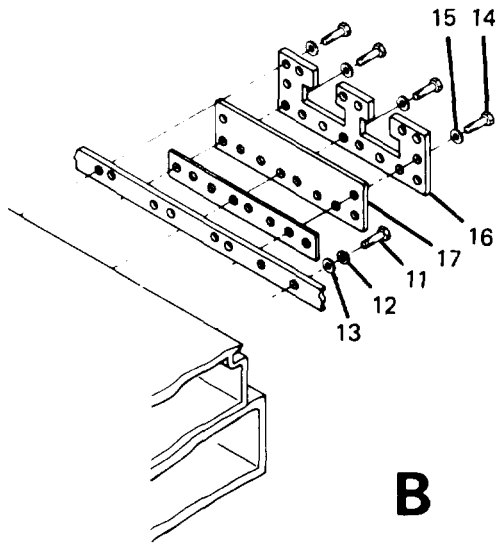

APPENDIX A

REFERENCES

A-1. SCOPE

This appendix lists all forms, field manuals, technical manuals and miscellaneous publications referenced in this manual.

A-2. FORMS

- (A) Recommended Changes to Publications on Blank Forms . . . DA-2028
- (F) Reporting Errors And Improvement AFTO-22
- (A) Transportation Discrepancy Report SF-361
- (A) Quality Deficiency Report SF-368

A-3. FIELD MANUALS

- (A) Destruction Of Equipment to Prevent Enemy Use TM 750-244-3
- (F) Inspection Manual TO 35C2-3

A-4. TECHNICAL MANUALS

- Repair Parts and Special Tools List TM 10-5411-200-24P
- (F) Maintenance Reporting AFM 66-1
- (A) The Army Maintenance Management System DA Pamphlet 738-750

APPENDIX B

MAINTENANCE ALLOCATION CHART

SECTION I. INTRODUCTION

B-1. The Army Maintenance System MAC

This introduction provides a general explanation of all maintenance and repair functions authorized at the two maintenance levels under the Two-Level Maintenance System concept.

This MAC (immediately following the introduction) designates overall authority and responsibility for the performance of maintenance functions on the identified end item or component. The application of the maintenance functions to the end item or component shall be consistent with the capacities and capabilities of the designated maintenance levels, which are shown on the MAC in column (4) as:

Field - includes two columns, Unit maintenance and Direct Support maintenance. The Unit maintenance column is divided again into two more subcolumns, C for Operator or Crew and O for Unit maintenance.

Sustainment – includes two subcolumns, General Support (H) and Depot (D).

In Section III, the tools and test equipment requirements (immediately following the MAC) list the tools and test equipment (both special tools and common tool sets) required for each maintenance function as referenced from the MAC (Section II).

In Section IV, the remarks (immediately following the tools and test equipment requirements) contain supplemental instructions and explanatory notes for a particular maintenance function.

B-2. Maintenance Functions

Maintenance functions are limited to and defined as follows:

1. Inspect. To determine the serviceability of an item by comparing its physical, mechanical, and/or electrical characteristics with established standards through examination (e.g., by sight, sound, or feel.) This includes scheduled inspection and gagging and evaluation of cannon tubes.
2. Test. To verify serviceability by measuring the mechanical, pneumatic, hydraulic, or electrical characteristics of an item and comparing those characteristics with prescribed standards on a scheduled basis, i.e., load testing of lift devices and hydrostatic testing of pressure hoses.
3. Service. Operations required periodically to keep an item in proper operating condition; e.g., to clean (includes decontaminate, when required), to preserve, to drain, to paint, or to replenish fuel, lubricants, chemical fluids, or gases. This includes scheduled exercising and purging of recoil mechanisms. The following are examples of service functions:
 - a. Unpack. To remove from packing box for service or when required for the performance of maintenance operations.

- b. Repack. To return item to packing box after service and other maintenance operations.
 - c. Clean. To rid the item of contamination.
 - d. Touch up. To spot paint scratched or blistered surfaces.
 - e. Mark. To restore obliterated identification.
4. Adjust. To maintain or regulate, within prescribed limits, by bringing into proper position, or by setting the operating characteristics to specified parameters.
 5. Align. To adjust specified variable elements of an item to bring about optimum or desired performance
 6. Calibrate. To determine and cause corrections to be made or to be adjusted on instruments of test, measuring, and diagnostic equipment used in precision measurement. Consists of comparisons of two instruments, one of which is a certified standard of known accuracy, to detect and adjust any discrepancy in the accuracy of the instrument being compared.
 7. Remove/Install. To remove and install the same item when required to perform service or other maintenance functions. Install may be the act of emplacing, seating, or fixing into position a spare, repair part, or module (component or assembly) in a manner to allow the proper functioning of an equipment or system.
 8. Paint. To prepare and spray color coats of paint so that the ammunition can be identified and protected. The color indicating primary use is applied, preferably, to the entire exterior surface as the background color of the item. Other markings are to be repainted as original so as to retain proper ammunition identification.
 9. Replace. To remove an unserviceable item and install a serviceable counterpart in its place. "Replace" is authorized by the MAC and assigned maintenance level is shown as the third position code of the Source, Maintenance and Recoverability (SMR) code.
 10. Repair. The application of maintenance services, including fault location/troubleshooting, removal/installation, disassembly/assembly procedures and maintenance actions to identify troubles and restore serviceability to an item by correcting specific damage, fault, malfunction, or failure in a part, subassembly, module (component or assembly), end item, or system.

NOTE

The following definitions are applicable to the “repair” maintenance function:

Services. Inspect, test, service, adjust, align, calibrate, and/or replace.

Fault location/troubleshooting. The process of investigating and detecting the cause of equipment malfunctioning; the act of isolating a fault within a system or Unit Under Test (UUT).

Disassembly/assembly. The step-by-step breakdown (taking apart) of a spare/functional group coded item to the level of its least component, that is assigned an SMR code for the level of maintenance under consideration (i.e., identified as maintenance significant).

Actions. Welding, grinding, riveting, straightening, facing, machining, and/or resurfacing.

11. Overhaul. That maintenance effort (service/action) prescribed to restore an item to a completely serviceable/operational condition as required by maintenance standards in appropriate technical publications. Overhaul is normally the highest degree of maintenance performed by the Army. Overhaul does not normally return an item to like new condition.
12. Rebuild. Consists of those services/actions necessary for the restoration of unserviceable equipment to a like new condition in accordance with original manufacturing standards. Rebuild is the highest degree of material maintenance applied to Army equipment. The rebuild operation includes the act of returning to zero those age measurements (e.g., hours/miles) considered in classifying Army equipment/components.

B-3. Explanation of Columns in the MAC, Section II.

Column (1) Group Number. Column (1) lists Functional Group Code (FGC) numbers, the purpose of which is to identify maintenance significant components, assemblies, subassemblies, and modules with the Next Higher Assembly (NHA).

Column (2) Component/Assembly. Column (2) contains the names of components, assemblies, subassemblies, and modules for which maintenance is authorized.

Column (3) Maintenance Function. Column (3) lists the functions to be performed on the item listed in column (2). (For a detailed explanation of these functions refer to “Maintenance Functions” outlined above).

Column (4) Maintenance Level. Column (4) specifies each level of maintenance authorized to perform each function listed in column (3), by indicating work time required (expressed as manhours in whole hours or decimals) in the appropriate subcolumn. This work time figure represents the active time required to perform that maintenance function at the indicated level of maintenance. If the number or complexity of the tasks within the listed maintenance function varies at different maintenance levels, appropriate work time figures are to be shown for each level. The work time figure represents the average time required to restore an item (assembly, subassembly, component, module, end item, or system) to a serviceable condition under typical field operating conditions. This time includes preparation time (including any necessary disassembly/assembly time), troubleshooting/fault location time, and quality assurance time in addition to the time required to perform the specific tasks identified for the maintenance functions authorized in the MAC. The system designations for the various maintenance levels are as follows:

Field:

- C Operator or crew maintenance
- O Unit maintenance
- F Direct Support maintenance

Sustainment:

- L Specialized Repair Activity
- H General Support maintenance
- D Depot maintenance

NOTE

The "L" maintenance level is not included in column (4) of the MAC. Functions to this level of maintenance are identified by work time figure in the "H" column of column (4), and an associated reference code is used in the REMARKS column (6). This code is keyed to the remarks and the SRA complete repair application is explained there.

Column (5) Tools and Equipment Reference Code. Column (5) specifies, by code, those common tool sets (not individual tools), common Test, Measurement and Diagnostic Equipment (TMDE), and special tools, special TMDE and special support equipment required to perform the designated function. Codes are keyed to the entries in the tools and test equipment table.

Column (6) Remarks Code. When applicable, this column contains a letter code, in alphabetic order, which is keyed to the remarks table entries.

B-4. Explanation of Columns in the Tools and Test Equipment Requirements, Section III.

Column (1) - Tool or Test Equipment Reference Code. The tool or test equipment reference code correlates with a code used in column (5) of the MAC.

Column (2) - Maintenance Level. The lowest level of maintenance authorized to use the tool or test equipment.

Column (3) - Nomenclature. Name or identification of tool or test equipment.

Column (4) - National Stock Number (NSN). The NSN of the tool or test equipment.

Column (5) - Tool Number. The manufacturer's part number.

B-5. Explanation of Columns in Remarks, Section IV.

Column (1) - Remarks Code. The code recorded in column (6) of the MAC.

Column (2) - Remarks. This column lists information pertinent to the maintenance function being performed as indicated in the MAC.

**SECTION II. MAINTENANCE ALLOCATION CHART
FOR
SHELTER, TACTICAL, EXPANDABLE, TWO-SIDED**

(1) GROUP NUMBER	(2) COMPONENT/ ASSEMBLY	(3) MAINTENANCE FUNCTION	(4) MAINTENANCE LEVEL					(5) TOOLS AND EQUIPMENT REFERENCE CODE	(6) REMARKS CODE						
			FIELD		SUSTAINMENT										
			UNIT		DIRECT SUPPORT	GENERAL SUPPORT	DEPOT								
			C	O	F	H	D								
01	ELECTRICAL SYSTEM	Inspect Test Replace Repair	0.2	0.2	1.0 0.5			4 1 1							
									PANEL WIRING	Inspect Test Replace Repair	0.2	0.2 0.5 0.5			4 1 1
	CIRCUIT BREAKERS	Inspect Test Replace	0.2	0.1 0.2			4 1								

**SECTION II. MAINTENANCE ALLOCATION CHART
FOR
SHELTER, TACTICAL, EXPANDABLE, TWO-SIDED - continued**

(1) GROUP NUMBER	(2) COMPONENT/ ASSEMBLY	(3) MAINTENANCE FUNCTION	(4) MAINTENANCE LEVEL					(5) TOOLS AND EQUIPMENT REFERENCE CODE	(6) REMARKS CODE
			FIELD		SUSTAINMENT				
			UNIT		DIRECT SUPPORT	GENERAL SUPPORT	DEPOT		
			C	O	F	H	D		
01 – cont.	POWER ENTRY PANEL ASSEMBLY	Inspect	0.2						
		Test		0.2				4	
		Replace			1.0			1,2	
		Repair			0.5			1,2,12	
	RECEPTACLES	Inspect	0.1						
		Test		0.2				4	
		Replace		0.3				1,12	
		Repair		0.3				1	
	TERMINALS/ CONNECTORS	Inspect	0.2						
		Replace		0.3				1	
		Repair		0.3				1	
	AREA LIGHT ASSEMBLY	Inspect	0.1						
Test			0.1				4		
Replace		0.1					1		
INCANDESCENT LIGHT ASSEMBLY	Repair		0.5				1,2		
	Inspect	0.1							
	Test		0.1				4		
CEILING LIGHT HINGED ROOF AREA	Replace		0.5				1		
	Repair		0.3				1		
	Inspect	0.1							
CEILING LIGHT FIXED ROOF AREA	Test		0.1				4		
	Replace	0.2							
	Repair		0.5				1,2		
RECEPTACLE OUTLETS	Inspect	0.1							
	Test		0.1				4		
	Replace		0.3				9		
	Repair		0.2				1		
SWITCHES, WALL	Inspect	0.1							
	Replace		0.3				1		

**SECTION II. MAINTENANCE ALLOCATION CHART
FOR
SHELTER, TACTICAL, EXPANDABLE, TWO-SIDED - continued**

(1) GROUP NUMBER	(2) COMPONENT/ ASSEMBLY	(3) MAINTENANCE FUNCTION	(4) MAINTENANCE LEVEL					(5) TOOLS AND EQUIPMENT REFERENCE CODE	(6) REMARKS CODE
			FIELD		SUSTAINMENT				
			UNIT		DIRECT SUPPORT	GENERAL SUPPORT	DEPOT		
			C	O	F	H	D		
01 – cont.	SWITCH, BLACKOUT	Inspect	0.1						
		Replace		1.5				1	
		Repair		0.5				1	
		Adjust		0.2				1	
02	WIRING	Inspect	0.3						
		Test		0.3				4	
		Replace		4.0				1	
		Repair		2.0				1	
02	DOOR ASSEMBLIES	Inspect	0.1						
		Replace		0.5				1,2	
		Repair		2.0				1	
		Align		0.2				1	
	DOOR VENT	Inspect	0.1						
		Replace		1.0				1	
		Repair		0.5				1,2	
		Align		0.2				1,2	
	DOOR LOCK ASSEMBLY	Inspect	0.1						
		Replace		0.3				1,2	
		Repair		0.2				1	
	DOOR STOP ASSEMBLY	Inspect	0.1						
		Replace		0.2				1	
		Repair		0.2				1,2	
DOOR, LEFT CARGO	Inspect	0.1							
	Replace		0.5				1		
	Repair		2.0				1		
	Align		0.2				1		
FOOT BOLT ASSEMBLY	Inspect	0.1							
	Replace		0.2				1		
	Repair		0.2				1		
	Align		0.2				1		
CHAIN BOLT ASSEMBLY	Inspect	0.1							
	Replace		0.2				1		
	Repair		0.2				1		

**SECTION II. MAINTENANCE ALLOCATION CHART
FOR
SHELTER, TACTICAL, EXPANDABLE, TWO-SIDED - continued**

(1) GROUP NUMBER	(2) COMPONENT/ ASSEMBLY	(3) MAINTENANCE FUNCTION	(4) MAINTENANCE LEVEL					(5) TOOLS AND EQUIPMENT REFERENCE CODE	(6) REMARKS CODE
			FIELD		SUSTAINMENT				
			UNIT		DIRECT SUPPORT	GENERAL SUPPORT	DEPOT		
			C	O	F	H	D		
03	LEVELING JACK ASSEMBLIES	Inspect	0.2						
		Service		0.1				5	
04	HINGED PANEL ASSEMBLIES	Replace	0.2					1	
		Repair		0.5				1	
	ROOF PANELS, HINGED	Inspect	0.2						
		Service		0.2					
		Replace		1.0				1	
		Repair		2.5				1,2	
		Align		0.3				1	
	SUPPORT STRUT ASSEMBLIES	Inspect	0.1						
		Repair		1.2				1	
	ENDWALL, HINGED	Inspect	0.2						
		Repair		1.0				1,2	
	CLOSEOUT PANEL, ENDWALL	Inspect	0.2						
		Repair		1.0				1	
	LATCHES	Inspect	0.1						
Repair			1.0				1		
SIDEWALLS, HINGED	Inspect	0.2							
	Repair		1.5				1,2		
CLOSEOUT PANELS, SIDEWALL	Inspect	0.2							
	Repair		1.0				1,2,10		
ECU INTAKE PANEL	Inspect	0.1							
	Repair		0.5				1,2,3		

**SECTION II. MAINTENANCE ALLOCATION CHART
FOR
SHELTER, TACTICAL, EXPANDABLE, TWO-SIDED - continued**

(1) GROUP NUMBER	(2) COMPONENT/ ASSEMBLY	(3) MAINTENANCE FUNCTION	(4) MAINTENANCE LEVEL					(5) TOOLS AND EQUIPMENT REFERENCE CODE	(6) REMARKS CODE	
			FIELD		SUSTAINMENT					
			UNIT		DIRECT SUPPORT	GENERAL SUPPORT	DEPOT			
			C	O	F	H	D			
04 – cont.	ECU RETURN PANEL	Inspect	0.1							
		Replace	0.1					1		
		Repair		0.5				1,3		
	FLOOR PANEL, HINGED	Inspect	0.5							
		Replace		3.0				1		
		Repair		2.0				1,2		
05	CONTAINER LIFT JACK ASSEMBLIES	Inspect	0.2							
		Service		0.1				5		
		Replace	0.2					1		
		Repair		0.5				1		
		06	FIXED PANEL ASSEMBLIES	Inspect	0.2					
					Replace		4.0			
Repair					2.0				1,2	
	LEVEL ASSEMBLY	Inspect	0.1							
		Replace		0.5				2		
		Repair		0.4				1		
	STEP, FOLDING	Inspect	0.1							
		Replace		0.2				1		
		Repair		0.2				1		
	ENDWALL PANEL, CARGO DOOR END	Inspect	0.2							
		Replace		3.0				1		
		Repair		2.0				1,2		
	ROOF PANEL	Inspect	0.3							
		Replace			6.0			1,6,7		
		Repair		3.0				1,2		
	LOAD BALANCER AND CABLE ASSEMBLY	Inspect	0.2							
		Replace		0.5				1		
	STOWAGE BRACKETS	Inspect	0.1							
		Replace		0.2				1		
		Repair		0.2				1		

**SECTION II. MAINTENANCE ALLOCATION CHART
FOR
SHELTER, TACTICAL, EXPANDABLE, TWO-SIDED - continued**

(1) GROUP NUMBER	(2) COMPONENT/ ASSEMBLY	(3) MAINTENANCE FUNCTION	(4) MAINTENANCE LEVEL					(5) TOOLS AND EQUIPMENT REFERENCE CODE	(6) REMARKS CODE
			FIELD		SUSTAINMENT				
			UNIT		DIRECT SUPPORT	GENERAL SUPPORT	DEPOT		
			C	O	F	H	D		
05 - cont.	SOLAR BAR ASSEMBLY	Inspect	0.2						
		Replace		2.0				1	
		Repair		1.0				1	
07	FLOOR PANEL	Inspect	0.2						
		Replace			12.0			1, 2, 7, 8	
		Repair		3.0				1, 13, 14	
08	FRAME ASSEMBLY	Inspect	0.2						
		Replace			14.0			1,2	
		Repair			1.5			1,2	
08	CORNER POST AND ISO FITTING ASSEMBLY	Inspect	0.2						
		Replace							
	Repair								
	HANDLE, CAMLOCK AND LATCH CAM	Inspect	0.2						
		Replace		0.3				1	
			Repair		0.3			1	
	MICELLANEOUS COMPONENTS	Inspect	0.2						
Replace									
		Repair							
EQUIPMENT CONTAINER	Inspect	0.2							
	Replace			0.2			1		
		Repair		0.5					
STORM CONFIGURATION COMPONENTS	Inspect	0.1							
	Replace		0.2				1		
SUPPORT BRACES	Inspect	0.1							
	Replace		0.1				1		
LEVELING JACK EXTENSIONS	Inspect	0.2							
	Replace		0.2				1		

**SECTION III. TOOL AND TEST EQUIPMENT REQUIREMENTS
FOR
SHELTER, TACTICAL, EXPANDABLE, TWO-SIDED**

(1) TOOL OR TEST EQUIPMENT REFERENCE CODE	(2) MAINTENANCE LEVEL	(3) NOMENCLATURE	(4) NATIONAL STOCK NUMBER	(5) TOOL NUMBER
1	C, O, F, H	Tool Kit, General Mechanics	5180-00-177-7033	
2	O, F, H	Riveter, Blind Hand	5120-00-017-2849	
3	C	Installation Tool		FSCM 08524 FRB703-12
4	O	Multimeter	6625-00-999-6282	
5	O	Tool Kit, Electrical	5180-00-876-9336	
6	O	Drill, Electric, Portable ¼ inch cap	5130-00-204-2778	
7	O	Fastener Header (10-32, ¼-28)		FSCM 03481 C845
8	O	Fastener Header (5/16-24, 3/8-24)		FSCM 03481 C-722
9	O	Installation Tool		FSCM 94222 29-47-102-10
10	O	Snap Ring Pliers	5120-00-789-0492	
11	O	Wrench, Box End or Adjustable		
12	O	Crimping Tool		FSCM 56501 TBM5
13	O	Tool Kit, Blind Bolt Removal		FSCM 17446 105-60
14	O	Installation Tool		FSCM 17446 115
15	O	Router, Electric, Portable	5130-00-990-4449	
16	O	Heat Lamp, Tripod Base		FSCM 39428 8439K11

SECTION IV. REMARKS
FOR
SHELTER, TACTICAL, EXPANDABLE, TWO-SIDED

(1) REMARKS CODE	(2) REMARKS
	Not applicable

APPENDIX C

COMPONENTS OF THE END ITEM LIST

Section I. INTRODUCTION

C-1. SCOPE

This appendix lists components of end item for the shelter to help you inventory items required for safe and efficient operation.

C-2. GENERAL

The Components of End Item List is provided in Section II. This listing is for informational purposes only, and is not authority to requisition replacements. These items are part of the end item, but are removed and separately packaged for transportation or shipment. As part of the end item, these items must be with the end item whenever it is issued or transferred between property accounts. Illustrations are furnished to assist you in identifying the items.

C-3. EXPLANATION OF COLUMNS IN SECTION II

The following provides an explanation of columns found in the tabular listings:

a. Column (1) - Illustration Number (Illus Number). This column indicates the number of the illustration in which the item is shown.

b. Column (2) - National Stock Number. Indicates the National stock number assigned to the item and will be used for requisitioning purposes.

c* Column (3) - Description. Indicates the Federal item name and, if required, a minimum description to identify and locate the item. The last line for each item indicates the FSCM (in parentheses) followed by the part number.

d. Column (4) - Unit of Measure (U/M). Indicates the measure used in performing the actual operational/maintenance function. This measure is expressed by a two-character alphabetical abbreviation (e.g., ea, in, pr) .

e. Column (5) - Quantity required (Qty rqr). Indicates the quantity of the item authorized to be used with/on the equipment.

Section II. COMPONENTS OF END ITEM

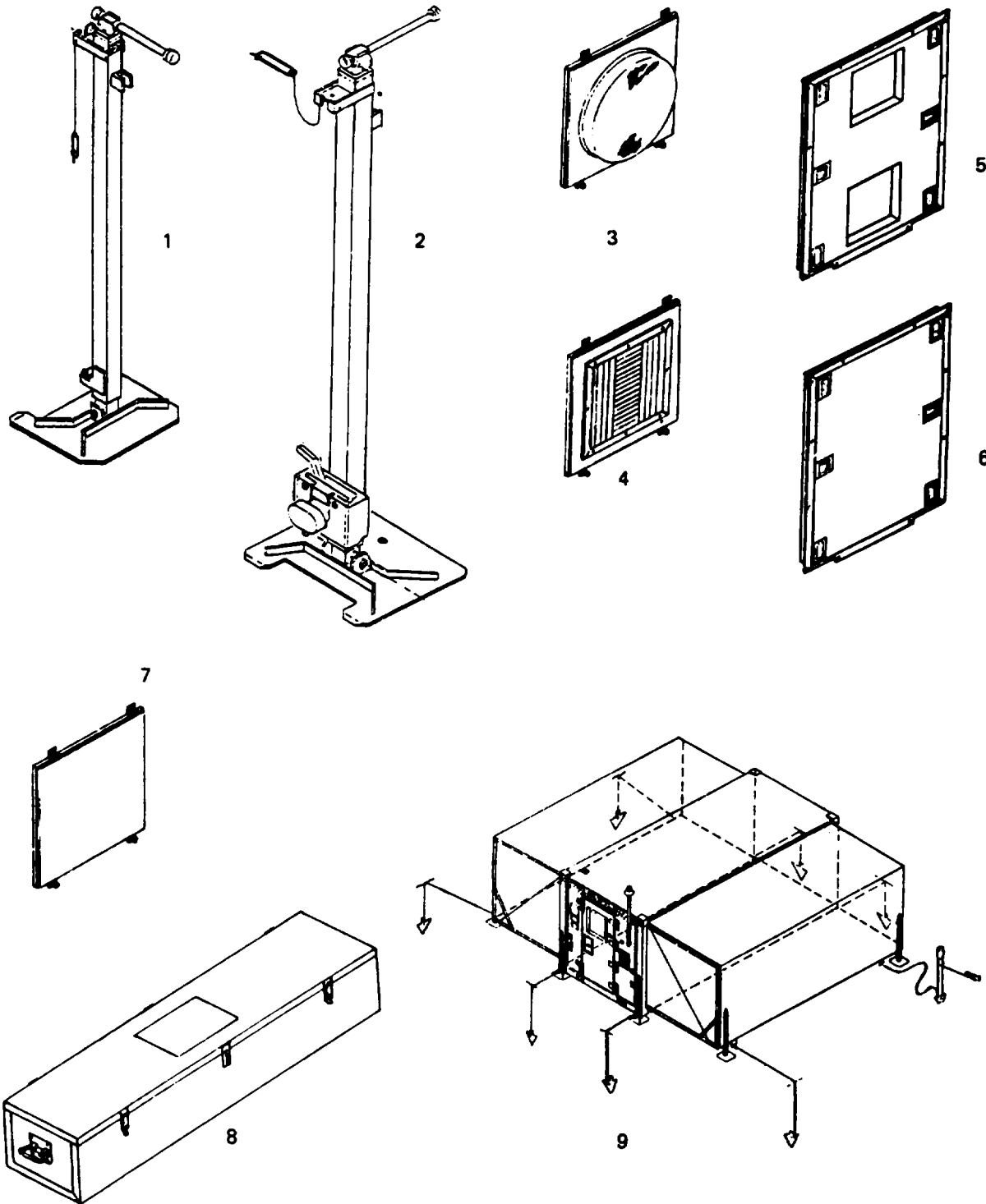

Section II. COMPONENTS OF END ITEM (cont)

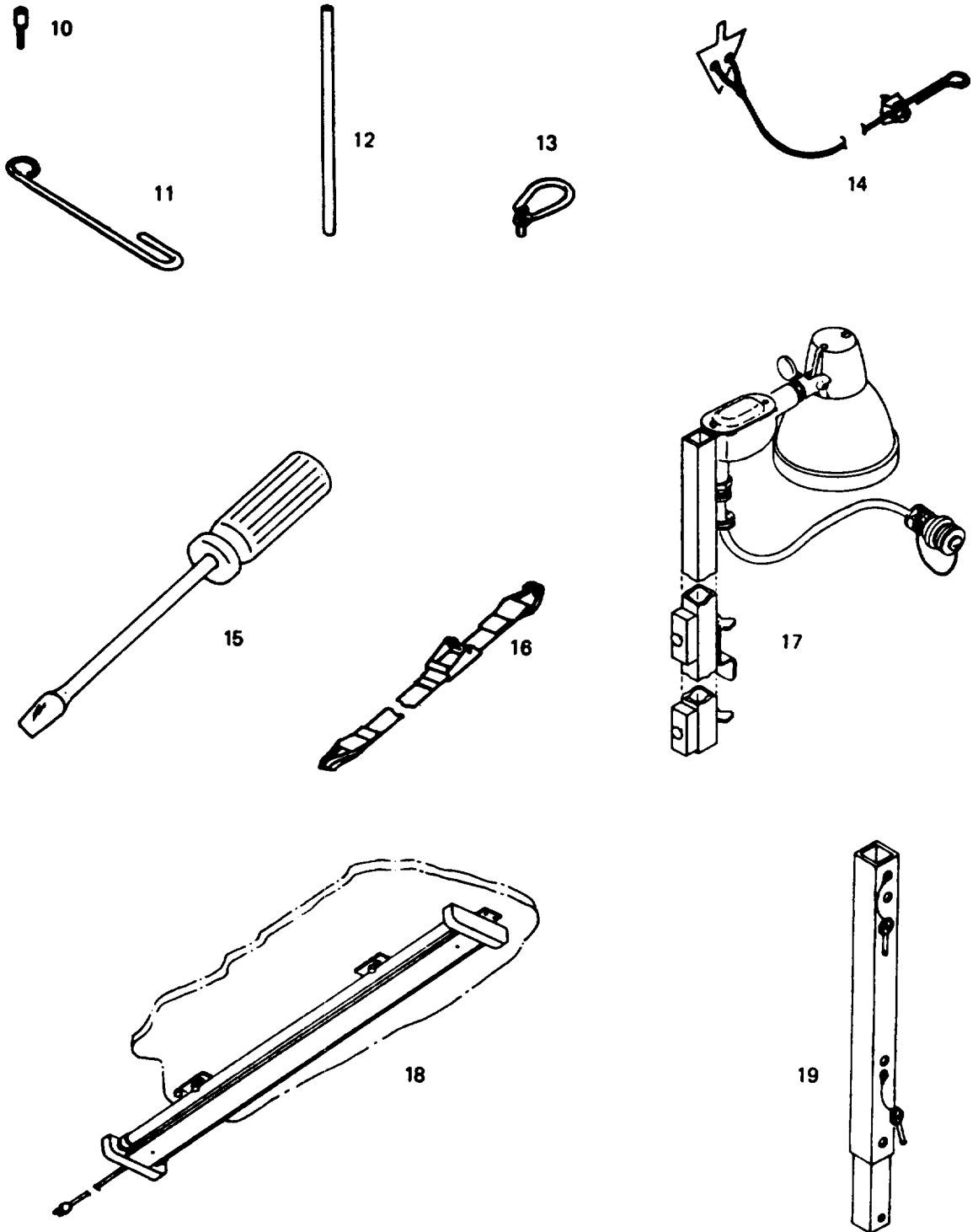

Section II. COMPONENTS OF END ITEM (cont)

(1) ILLUS/ ITEM NO.	(2) NATIONAL STOCK NUMBER	(3) DESCRIPTION CAGE AND PART NUMBER	(4) U/M	(5) QTY RQR
1		JACK ASSEMBLY, HINGED (81337) 5-4-2887-1	EA	4 /
2		JACK ASSEMBLY, INTERNATIONAL STANDARD FITTING (81337) 5-4-2866-1	EA	4
3		PANEL ASSEMBLY, ECU RETURN (81337) 5-4-2857-1	EA	1
4		PANEL ASSEMBLY, ECU INTAKE (81337) 5-4-2856-1	EA	1
5		CLOSEOUT PANEL ASSEMBLY WITH ECU OPENINGS (81337) 5-4-4657	EA	1
6		CLOSEOUT PANEL ASSEMBLY 58.5 x 77.0 (81337) 5-4-4790	EA	3
7		CLOSEOUT PANEL ASSEMBLY 21 x 21 (81337) 5-4-2853-1	EA	2
8		EQUIPMENT CONTAINER WITH CONTENTS (81337) 5-4-5097	EA	1
9		TIEDOWN INSTALLATION (81337) 5-4-4712	EA	1
10		DRIVE HEAD (81349) MIL-A-3962 size 4 inch	EA	1
11		HOLDING HANDLE (81349) MIL-A-3962 size 4,6, or 8 inch	EA	1
12		DRIVE ROD (81349) MIL-A-3962 size 4 inch	EA	1
13		TIEDOWN RING (81337) 5-4-3020	EA	2

Section II. COMPONENTS OF END ITEM (cont)

(1) Illus Number	(2) National Stock Number	(3) Description FSCM and Part Number	(4) U/M	(5) Qty rqr
14		GROUND ANCHOR ASSEMBLY (81337) 5-4-2981	EA	8
15		SCREWDRIVER, FLAT TIP, 10-INCH ASME B107.5, Type 1, Class 2, design A Flat tip width .312 Flat tip thickness at tip .046 in.	EA	1
16		STRAP ASSEMBLY, TIEDOWN (81337) 5-4-4944	EA	2
17		LIGHT ASSEMBLY, EXTERIOR (81337) 5-4-2974	EA	1
18		LIGHT ASSEMBLY, REMOVABLE (81337) 5-4-4679	EA	6
19		EXTENSION ASSEMBLY, JACK (81337) 5-4-2893-1	EA	4
20		PHILLIPS SCREWDRIVER, 4 INCH ASME B107.5, TYPE II, DESIGN A POINT SIZE 2	EA	1
21		FLOODLIGHT, 150 WATT (81337) 5-4-4871	EA	1
22		LATCH ASSEMBLY (81337) 5-4-3128	EA	4
23		BRACE, HINGED FLOOR (81337) 5-4-4764	EA	2

APPENDIX D

ADDITIONAL AUTHORIZATION LIST

Section I. INTRODUCTION

D1. SCOPE

This appendix lists additional items you are authorized for the use of the shelter.

D-2. GENERAL

This list identifies items that do not have to accompany the shelter and that do not have to be turned in with it. These items are all authorized to you by CTA, MTOE, TDA, or JTA.

D-3. EXPLANATION OF LISTING

National stock numbers, descriptions, and quantities are provided to help you identify and request the additional items you require to support this equipment.

Section II. ADDITIONAL AUTHORIZATION LIST

(1) NATIONAL STOCK NUMBER	(2) DESCRIPTION CAGEC & PART NUMBER	(3) AUTH	(4) QTY U/M
	CONTAINER LIFT SLING, bottom lifting (65058) 74016B-20	EA	1
	CONTAINER LIFT SLING, top lifting (65059) 74016T-1A	EA	1
597540-878-3781	GROUND ROD ASSEMBLY	EA	1
5120-00-293-0887	SLEDGE HAMMER, 12 pound	EA	1
5120-01-013-1676	SLIDE HAMMER, ground	EA	1
5210-00-239-0882	LEVEL, CARPENTER'S, 24-inch	EA	1
6150-01-256-6301	FEEDER, PIGTAIL, 40/60 Amp, 4 ft lg, (97403) 13226E7019	EA	1
6150-01-247-4781	CABLE, SERVICE, 40/60 Amp, 50 ft lg, (97403) 13226E7023-2	EA	1
6150-01-247-4779	CABLE, SERVICE, 40/60 Amp, 100 ft lg, (97403) 13226E7023-1	EA	1
6150-01-256-6300	FEEDER, PIGTAIL, 100 Amp, 4 ft lg, (97403) 13226E7020	EA	1
6150-01-256-6304	CABLE, SERVICE, 100 Amp, 50 ft lg, (97403) 13226E7024	EA	1
	PLATE, STRIKE (For Overseas Transport) (81337) 5-4-6488	EA	1

(1) NATIONAL STOCK NUMBER	(2) DESCRIPTION CAGEC & PART NUMBER	(3) AUTH	(4) QTY U/M
	COMPLETING KIT PASSAGEWAY, TYPE II, CLASS A, STYLE 1, SAND, P/N 5-46730-1	EA	1
	COMPLETING KIT PASSAGEWAY, TYPE II, CLASS A, STYLE 1, GREEN, P/N 5-46730-2	EA	1
	COMPLEXING KIT PASSAGEWAY TYPE II, CLASS A, STYLE 2, SAND, P/N 5-46730-3	EA	1
	COMPLEXING KIT PASSAGEWAY, TYPE II, CLASS A, STYLE 2, GREEN, P/N 5-46730-4	EA	1
	COMPLETING KIT PASSAGEWAY, TYPE II, CLASS B, STYLE 1, SAND, P/N 5-46731-1	EA	1
	COMPLETING KIT PASSAGEWAY, TYPE II, CLASS B, STYLE 1, GREEN, P/N 5-4-6731-2	EA	1
	COMPLETING KIT PASSAGEWAY, TYPE II, CLASS B, STYLE 2, SAND, P/N 5-46731-3	EA	1
	COMPLETING KIT PASSAGEWAY, TYPE II, CLASS B, STYLE 2, GREEN, P/N 5-4-6731-4	EA	1
	COMPLEXING KIT PASSAGEWAY, TYPE I, STYLE 1, SAND, P/N 5-4-6732-1	EA	1
	COMPLETING KIT PASSAGEWAY, TYPE I, STYLE 1, GREEN, P/N 5-4-6732-2	EA	1
	COMPLETING KIT PASSAGEWAY, TYPE I, STYLE 2, SAND, P/N 546732-3	EA	1
	COMPLETING KIT PASSAGEWAY, TYPE I, STYLE 2, GREEN, P/N 5-4-6732-4	EA	1
	COMPLETING KIT PASSAGEWAY, TYPE I, STYLE 3, SAND, P/N 5-4-6732-5	EA	1
	COMPLETING KIT PASSAGEWAY, TYPE I, STYLE 3, GREEN. P/N 546731-6	EA	1

APPENDIX E

EXPENDABLE SUPPLIES AND MATERIALS LIST

Section I. INTRODUCTION

E-1. SCOPE

Section 11 of this appendix lists expendable supplies and materials you will need to operate and maintain the shelter. These items are authorized to you by CTA 50-970, Expendable Items.

E-2. EXPLANATION OF COLUMNS IN SECTION II

a. Column 1, Item Number. This number is assigned to the entry and is referenced in the narrative instructions to identify the material.

b. Column 2, Level. This column identifies the lowest level of maintenance that requires the listed item.

- C - Operator/Crew
- O - Organizational Maintenance
- F - Direct Support Maintenance
- H - General Support Maintenance

c. Column 3, National Stock Number. This is the National stock number assigned to the item; use it to request or requisition the item.

d. Column 4, Description. Indicates the Federal item name and, if required, a description to identify the item. The last line for each item indicates the Federal Supply Code for Manufacturer (FSCM) in parenthesis followed by the part number.

Column 5, Unit of Measure (U/M). Indicates the measure used in performing the actual maintenance function. This measure is expressed by a two character alphabetical abbreviation (e.g., ea, in, pr). If the unit of measure differs from the unit of issue, requisition the lowest unit of issue that will satisfy your requirements.

Section II. EXPENDABLE SUPPLIES AND MATERIALS LIST

(1) ITEM NUMBER	(2) LEVEL	(3) NATIONAL STOCK NUMBER	(4) DESCRIPTION	(5) U/M
1			Adhesive, (92528) FE60268	
2		8040-00-865-8991	Adhesive, Silicone, Rubber, Aluminum	12 oz can
3		8040-00-142-9823	Adhesive, Silicone, Rubber, Black	12 oz tube
4			Aluminum Patch, 0.040 in. thick x 12 x 12 in. (1.02 mm x 30.48 x 30.48 cm), FED STD 200/8 5052-H34	
5			Cloth, Cotton, Wiping, FED STD DDD-R30	
6			Coating system, epoxy-polyimide, MIL-C-22751	
7			Core, 3 in. thick x 12 x 12 ± 1 (76.2 mm x 30.48 x 30.48 ± 2.54 cm) ASTM-E-1091-86-TYPEIV	
8			Core, 2 1/2 in. thick x 12 x 12 ± 1 (63.5 mm x 30.48 x 30.48 ± 2.54 cm) ASTM-E-1091-86-TYPEIV	
9			Core, 2 in. thick x 12 x 12 ± 1 (50.8 mm x 30.48 x 30.48 ± 2.54 cm) ASTM-E-1091-86-TYPEIV	
10			Core, 1 1/2 in. thick x 12 x 12 ± 1 (38.1 mm x 30.48 + 2.54 cm) ASTM-E-1091-86-TYPEIV	
11		8415-00-634-5027	Gloves, White	Pair
12			Grease, Automotive, MIL-G-10924	
13			Rivet, Blind, Closed-end Sealing, 3/16 dia. 0.063 - 0.125 grip, (07707) AD62H Rivet, Blind, Closed-end Sealing, 3/16 dia. 0.126 - 0.250 grip, (07707) AD64H	
14			Rivet, Blind, Closed-end Sealing, 3/16 dia. 0.251 - 0.375 grip, (07707) AD66H Rivet, Blind, Closed-end Sealing, 3/16 dia. 0.376 - 0.500 grip, (07707) AD68H	
15			Rivet, Blind, Closed-end Sealing, 1/8 dia. 0.063 - 0.125 grip, (07707) AD42H Rivet, Blind, Closed-end Sealing, 1/8 dia. 0.126 - 0.187 grip, (07707) AD43H	
16			Rivet, Blind, Closed-end Sealing, 1/8 dia. 0.188 - 0.250 grip, (07707) AD44H Rivet, Blind, Closed-end Sealing, 1/8 dia. 0.251 - 0.312 grip, (07707) AD45H	

Section II. EXPENDABLE SUPPLIES AND MATERIALS (cont)

(1) ITEM NUMBER	(2) LEVEL	(3) NATIONAL STOCK NUMBER	(4) DESCRIPTION	(5) U/M
17			Sandpaper, 120/220 GRIT, FED STD P-P-101	
18			Sealant, MIL-S-22473	
19			Sealing Compound, MIL-S-8802, Class B	
20		6180-00-687-8429	Solvent, Methylketone, T-T-M-261	64 oz cn
21			Stick, Stirring, Wood FED ST0 A-A-1081	
22		7510-00-266-7612	Tape, Pressure Sensitive, 1 in wide (2.54 cm)	Roll
		7510-00-266-7614	Tape, Pressure Sensitive, 1.5 in wide, (3.81 cm)	Roll
23			Grease, Silicone (5D028), Dow Coming III Compound	
24			Aluminum Sheet, 1/8 in thick X 2 in square (3.2 min X 50.8 max), QQA-200/8 5052-H-34	
25		9550-00-402-4478	Lubricant, Spray, MIL-L-23398	Can
26			Blind Nut Assy, (73197) BN532-524-122	Each
27		5411-01-352-8568	Repair Kit, Shelter	Each
28			Walkway Compound, MIL-W-5044, Type I Color Gray No. 26251, FED-ST0595	Each
29			Walkway Compound, MIL-W-5044, Type II Color Gray No. 26251, FED-STD-595	Each

I N D E X

Subject	Paragraph, Figure, Table Number
A	
Administrative Storage	1-4
Area Light Assembly Replacement	3-4
Area Light Assembly Testing and Repair	4-9
Area Light Installation	2-14
B	
Blackout Switch Replacement Repair, and Adjustment	4-15
Blind Rivet Removal and Installation	4-32
C	
Camlock and Latch Cam Handle Replacement and Repair	4-29
Cargo Door End Endwall Panel Replacement and Repair	4-26
Caulking Repaired Areas	4-42
Ceiling Lights and Utility Outlets Installation	2-13
Circuit Breaker Panel Assembly Replacement and Repair	5-2
Circuit Breaker Panel Assembly Testing, Replacement and Repair	4-7, 4-7.1
Circuit Breaker Panel Controls and Indicators	2-2
Closing Sequence	2-16
Common Tools and Equipment	4-1
Container Lift Jack Assembly Replacement	3-9
Container Lift Jack Assembly Service and Repair	4-24
Corner Post and ISO Fitting Assembly Replacement and Repair	5-5
D	
Decal Removal and Replacement	4-44
Destruction of Materiel to Prevent Enemy Use	1-3
Drying Water Soaked Areas in Panels	4-31
E	
Electrical System Schematic Diagram - 60 Amp Service	4-45
Electrical System Schematic Diagram - 100 Amp Service	4-47
Endwall Closeout Panel Replacement	3-7
Equipment Container Replacement and Repair	4-30
Equipment Data	1-9
Explanation of Columns in Section II	B-2, C-2, E-2
Explanation of Columns in Section III	B-3
External Connections	2-15

INDEX (continued)

Subject	Paragraph, Figure, Table Number
F	
Field Manuals	A-3
Fixed Roof Area Ceiling Light Testing, Replacement and Repair	4-12
Floor Panel Repair	4-28
Floor Panel Replacement	6-2
Forms	A-2
General	2-4, 2-18 3-1, 3-3 4-4, 5-1 6-1, C-2
H	
Hinged Endwall Replacement and Repair	4-21
Hinged Floor Panel Replacement and Repair	4-23
Hinged Panel Leveling Jack Assembly Replacement	3-6
Hinged Panel Leveling Jack Assembly Service and Repair	4-19
Hinged Roof Area Ceiling Light Replacement	3-5
Hinged Roof Area Ceiling Light Testing and Repair	4-11
Hinged Roof Panel Service, Replacement, Repair and Alignment	4-20
Hinged Sidewall Replacement and Repair	4-22
I	
Incandescent Light Assembly Testing, Replacement and Repair	4-10
L	
Left Cargo Door Replacement, Repair and Alignment	4-18
List of Abbreviations	1-6
Location and Description of Major Components	1-8
Location of Identification and Instruction Plates	2-11
Maintenance Forms, Records, and Reports	1-2
O	
Operating Instructions	2-17
Operation During Blackout Conditions	2-22
Operation In High Winds	2-21
Operation In Rain and/or Mud	2-19
Operation In Snow, Ice or Extreme Cold	2-20
Operator Troubleshooting	3-2
Organizational Maintenance Troubleshooting	4-6

INDEX (continued)

Subject	Paragraph, Figure, Table Number
P	
Paint Refinishing	4-43
Personnel and Right Cargo Door Replacement, Repair and Alignment	4-17
Personnel Door End Endwall Panel Replacement and Repair	4-25
Personnel End Panel Mounted Controls and Indicators	2-3
Power Entry Panel Assembly Replacement and Repair	5-3
Power Entry Panel Assembly Testing, Replacement, and Repair	4-8
Preparation For Storage and Shipment	4-49
Preparation For Use	2-7
Preventive Maintenance Checks and Services Table	2-6
Purpose of Two-Sided Expandable Tactical Shelter Assembly	1-7
R	
Receptacle Outlets Testing, Replacement and Repair	4-13
Repair of Damage With Extended Cracks	4-37
Repair of Depression or Small Puncture	4-34
Repair of Puncture Through Both Skins and Core	4-39
Repair of Puncture Through One Skin and Core	4-38
Repair of Puncture With Core Fracture	4-36
Repair of Puncture With Minimal Damage to Core	4-35
Repair of Small Dent or Depression	4-33
Repair Parts	4-3
Replacement of Obsolete NQOB Circuit Breaker Panel With New NQOD Circuit Breaker Panel	4-7.1
Reporting Equipment Improvement Recommendations (EIR's)	1-5
Roof Panel Assembly Repair	4-27
Roof Panel Replacement	5-4
S	
Schematics	4-45, 4-47
Scope	1-1, 2-1, A-1 B-1, C-1, E-1
Shelter Body Seals Replacement	4-40
Shelter Expansion	2-12
Shelter Handling	2-10
Shelter Inspection Checklist	2-9
Shelter Inventory Checks	2-8
Sidewall Closeout, ECU Intake, and ECU Return Panels Replacement	3-8
Special Instructions	2-5

INDEX (continued)

Subject	Paragraph, Figure, Table Number
Special Tools, TMDE, and Support, Equipment	4-2
Storm Configuration Components, Support Braces, and Leveling Jack Extensions Replacement	3-10
T	
Technical Manuals	A-4
Threaded Inserts Replacement	4-41
Troubleshooting	4-5
W	
Wall Switches Replacement	4-14
■ Wire List	4-46, 4-48
Wiring Testing, Replacement, and Repair	4-16

By Order of the Secretaries of the Army, the Navy, and the Air Force:

Official:

R. L. DILWORTH
Brigadier General, United States Army
The Adjutant General

JOHN A. WICKHAM, JR.
General, United States Army
Chief of Staff

Official:

EARL T. O'LOUGHLIN
General, USAF, Commander, Air Force
Logistics Command

CHARLES A. GABRIEL, General USAF
Chief of Staff

DISTRIBUTION:

To be distributed in accordance with DA Form 12-25A Operator, Organizational and Direct Support and General Support Maintenance requirements for Shelter, Expandable, Rigid Construction, w/Air Lock Model SEU-2 (TM 10-5410-221 Series) and for Shelter, Expandable, Shop, Aircraft Maintenance, Portable (TM 10-5410-224 Series).

These are the instructions for sending an electronic 2028

The following format must be used if submitting an electronic 2028. The subject line must be exactly the same and all fields must be included; however, only the following fields are mandatory: 1, 3, 4, 5, 6, 7, 8, 9, 10, 13, 15, 16, 17, and 27.

From: "Whomever" whomever@avma27.army.mil

To: amssbriml@natick.army.mil

Subject: DA Form 2028

1. **From:** Joe Smith
2. **Unit** home
3. **Address:** 4300 Park
4. **City:** Hometown
5. **St:** MO
6. **Zip:** 77777
7. **Date Sent:** 19-OCT-93
8. **Pub no:** 55-2840-229-23
9. **Pub Title:** TM
10. **Publication Date:** 04-JUL-85
11. **Change Number:** 7
12. **Submitter Rank:** MSG
13. **Submitter FName:** Joe
14. **Submitter MName:** T
15. **Submitter LName:** Smith
16. **Submitter Phone:** 123-123-1234
17. **Problem:** 1
18. **Page:** 2
19. **Paragraph:** 3
20. **Line:** 4
21. **NSN:** 5
22. **Reference:** 6
23. **Figure:** 7
24. **Table:** 8
25. **Item:** 9
26. **Total:** 123
27. **Text:**

This is the text for the problem below line 27.

RECOMMENDED CHANGES TO PUBLICATIONS AND BLANK FORMS For use of this form, see AR 25-30; the proponent agency is ODISC4.						Use Part II (reverse) for Repair Parts and Special Tool Lists (RPSTL) and Supply Catalogs/Supply Manuals (SC/SM).	DATE <i>21 October 2003</i>
TO: (Forward to proponent of publication or form) (Include ZIP Code) COMMANDER U.S. ARMY TANK-AUTOMOTIVE AND ARMAMENT COMMAND ATTN: AMSTA-LC-CECT 15 KANSAS STREET NATICK, MA 01760-5052						FROM: (Activity and location) (Include ZIP Code) <i>PFC Jane Doe</i> <i>CO A 3rd Engineer BR</i> <i>Ft. Leonardwood, MO 63108</i>	
PART I – ALL PUBLICATIONS (EXCEPT RPSTL AND SC/SM) AND BLANK FORMS							
PUBLICATION/FORM NUMBER TM 10-1670-296-23&P				DATE 30 October 2002	TITLE Unit Manual for Ancillary Equipment for Low Velocity Air Drop Systems		
ITEM NO.	PAGE NO.	PARA-GRAPH	LINE NO. *	FIGURE NO.	TABLE NO.	RECOMMENDED CHANGES AND REASON <i>(Provide exact wording of recommended changes, if possible).</i>	
	0036 00-2				1	<i>In table 1, Sewing Machine Code Symbols, the second sewing machine code symbol should be MD ZZ not MD 22.</i> <i>Change the manual to show Sewing Machine, Industrial: Zig-Zag; 308 stitch; medium-duty; NSN 3530-01-181-1421 as a MD ZZ code symbol.</i>	
<small>*Reference to line numbers within the paragraph or subparagraph.</small>							
TYPED NAME, GRADE OR TITLE Jane Doe, PFC				TELEPHONE EXCHANGE/AUTOVON, PLUS EXTENSION 508-233-4141		SIGNATURE Jane Doe <i>Jane Doe</i>	

TO: <i>(Forward direct to addressee listed in publication)</i> COMMANDER U.S. ARMY TANK-AUTOMOTIVE AND ARMAMENT COMMAND ATTN: AMSTA-LC-CECT 15 KANSAS STREET NATICK, MA 01760-5052	FROM: <i>(Activity and location) (Include ZIP Code)</i> <i>PFC Jane Doe</i> <i>CO A 3rd Engineer BR</i> <i>Ft. Leonardwood, MO 63108</i>	DATE 21 October 2003
--	---	--------------------------------

PART II – REPAIR PARTS AND SPECIAL TOOL LISTS AND SUPPLY CATALOGS/SUPPLY MANUALS

PUBLICATION NUMBER TM 10-1670-296-23&P	DATE 30 October 2002	TITLE Unit Manual for Ancillary Equipment for Low Velocity Air Drop Systems
--	--------------------------------	---

PAGE NO.	COLM NO.	LINE NO.	NATIONAL STOCK NUMBER	REFERENCE NO.	FIGURE NO.	ITEM NO.	TOTAL NO. OF MAJOR ITEMS SUPPORTED	RECOMMENDED ACTION
0066 00-1					4			<i>Callout 16 in figure 4 is pointed to a <u>D-Ring</u>. In the Repair Parts List key for figure 4, item 16 is called a <u>Snap Hook</u>. Please correct one or the other.</i>

PART III – REMARKS *(Any general remarks or recommendations, or suggestions for improvement of publications and blank forms. Additional blank sheets may be used if more space is needed.)*

--	--	--

TYPED NAME, GRADE OR TITLE	TELEPHONE EXCHANGE/AUTOVON, PLUS EXTENSION	SIGNATURE
----------------------------	--	-----------

<p align="center">RECOMMENDED CHANGES TO PUBLICATIONS AND BLANK FORMS</p> <p>For use of this form, see AR 25-30; the proponent agency is ODISC4.</p>						Use Part II (reverse) for Repair Parts and Special Tool Lists (RPSTL) and Supply Catalogs/Supply Manuals (SC/SM).	DATE
TO: (Forward to proponent of publication or form) (Include ZIP Code) COMMANDER U.S. ARMYTANK-AUTOMOTIVE AND ARMAMENT COMMAND ATTN: AMSTA-LC-CECT 15 KANSAS STREET NATICK, MA 01760-5052						FROM: (Activity and location) (Include ZIP Code)	
PART I – ALL PUBLICATIONS (EXCEPT RPSTL AND SC/SM) AND BLANK FORMS							
PUBLICATION/FORM NUMBER TM 10-5411-200-14				DATE 1 April 1986	TITLE Shelter, Tactical Expandable, Two-Sided		
ITEM NO.	PAGE NO.	PARA-GRAPH	LINE NO. *	FIGURE NO.	TABLE NO.	RECOMMENDED CHANGES AND REASON <i>(Provide exact wording of recommended changes, if possible).</i>	
<i>*Reference to line numbers within the paragraph or subparagraph.</i>							
TYPED NAME, GRADE OR TITLE				TELEPHONE EXCHANGE/AUTOVON, PLUS EXTENSION		SIGNATURE	

TO: <i>(Forward direct to addressee listed in publication)</i> COMMANDER U.S. ARMYTANK-AUTOMOTIVE AND ARMAMENT COMMAND ATTN: AMSTA-LC-CECT 15 KANSAS STREET NATICK, MA 01760-5052	FROM: <i>(Activity and location) (Include ZIP Code)</i>	DATE
---	--	-------------

PART II – REPAIR PARTS AND SPECIAL TOOL LISTS AND SUPPLY CATALOGS/SUPPLY MANUALS

PUBLICATION NUMBER					DATE		TITLE	
TM10-5411-200-14					1 April 1986		Shelter, Tactical Expandable, Two-Sided	
PAGE NO.	COLM NO.	LINE NO.	NATIONAL STOCK NUMBER	REFERENCE NO.	FIGURE NO.	ITEM NO.	TOTAL NO. OF MAJOR ITEMS SUPPORTED	RECOMMENDED ACTION

PART III – REMARKS *(Any general remarks or recommendations, or suggestions for improvement of publications and blank forms. Additional blank sheets may be used if more space is needed.)*

TYPED NAME, GRADE OR TITLE	TELEPHONE EXCHANGE/AUTOVON, PLUS EXTENSION	SIGNATURE
----------------------------	--	-----------

<p align="center">RECOMMENDED CHANGES TO PUBLICATIONS AND BLANK FORMS</p> <p>For use of this form, see AR 25-30; the proponent agency is ODISC4.</p>						Use Part II (reverse) for Repair Parts and Special Tool Lists (RPSTL) and Supply Catalogs/Supply Manuals (SC/SM).	DATE
TO: (Forward to proponent of publication or form) (Include ZIP Code) COMMANDER U.S. ARMYTANK-AUTOMOTIVE AND ARMAMENT COMMAND ATTN: AMSTA-LC-CECT 15 KANSAS STREET NATICK, MA 01760-5052						FROM: (Activity and location) (Include ZIP Code)	
PART I – ALL PUBLICATIONS (EXCEPT RPSTL AND SC/SM) AND BLANK FORMS							
PUBLICATION/FORM NUMBER TM 10-5411-200-14				DATE 1 April 1986	TITLE Shelter, Tactical Expandable, Two-Sided		
ITEM NO.	PAGE NO.	PARA-GRAPH	LINE NO. *	FIGURE NO.	TABLE NO.	RECOMMENDED CHANGES AND REASON <i>(Provide exact wording of recommended changes, if possible).</i>	
<i>*Reference to line numbers within the paragraph or subparagraph.</i>							
TYPED NAME, GRADE OR TITLE				TELEPHONE EXCHANGE/AUTOVON, PLUS EXTENSION		SIGNATURE	

TO: <i>(Forward direct to addressee listed in publication)</i> COMMANDER U.S. ARMYTANK-AUTOMOTIVE AND ARMAMENT COMMAND ATTN: AMSTA-LC-CECT 15 KANSAS STREET NATICK, MA 01760-5052	FROM: <i>(Activity and location) (Include ZIP Code)</i>	DATE
---	--	-------------

PART II – REPAIR PARTS AND SPECIAL TOOL LISTS AND SUPPLY CATALOGS/SUPPLY MANUALS

PUBLICATION NUMBER TM10-5411-200-14					DATE 1 April 1986		TITLE Shelter, Tactical Expandable, Two-Sided	
PAGE NO.	COLM NO.	LINE NO.	NATIONAL STOCK NUMBER	REFERENCE NO.	FIGURE NO.	ITEM NO.	TOTAL NO. OF MAJOR ITEMS SUPPORTED	RECOMMENDED ACTION

PART III – REMARKS *(Any general remarks or recommendations, or suggestions for improvement of publications and blank forms. Additional blank sheets may be used if more space is needed.)*

TYPED NAME, GRADE OR TITLE	TELEPHONE EXCHANGE/AUTOVON, PLUS EXTENSION	SIGNATURE
----------------------------	--	-----------

The Metric System and Equivalents

Linear Measure

1 centimeter = 10 millimeters = .39 inch
 1 decimeter = 10 centimeters = 3.94 inches
 1 meter = 10 decimeters = 39.37 inches
 1 dekameter = 10 meters = 32.8 feet
 1 hectometer = 10 dekameters = 328.08 feet
 1 kilometer = 10 hectometers = 3,280.8 feet

Weights

1 centigram = 10 milligrams = .15 grain
 1 decigram = 10 centigrams = 1.54 grains
 1 gram = 10 decigrams = .035 ounce
 1 dekagram = 10 grams = .35 ounce
 1 hectogram = 10 dekagrams = 3.52 ounces
 1 kilogram = 10 hectograms = 2.2 pounds
 1 quintal = 100 kilograms = 220.46 pounds
 1 metric ton = 10 quintals = 1.1 short tons

Liquid Measure

1 centiliter = 10 milliliters = .34 fl. ounce
 1 deciliter = 10 centiliters = 3.38 fl. ounces
 1 liter = 10 deciliters = 33.81 fl. ounces
 1 dekaliter = 10 liters = 2.64 gallons
 1 hectoliter = 10 dekaliters = 26.42 gallons
 1 kiloliter = 10 hectoliters = 264.18 gallons

Square Measure

1 sq. centimeter = 100 sq. millimeters = .155 sq. inch
 1 sq. decimeter = 100 sq. centimeters = 15.5 sq. inches
 1 sq. meter (centare) = 100 sq. decimeters = 10.76 sq. feet
 1 sq. dekameter (are) = 100 sq. meters = 1,076.4 sq. feet
 1 sq. hectometer (hectare) = 100 sq. dekameters = 2.47 acres
 1 sq. kilometer = 100 sq. hectometers = .386 sq. mile

Cubic Measure

1 cu. centimeter = 1000 cu. millimeters = .06 cu. inch
 1 cu. decimeter = 1000 cu. centimeters = 61.02 cu. inches
 1 cu. meter = 1000 cu. decimeters = 35.31 feet

Approximate Conversion Factors

<i>To change</i>	<i>To</i>	<i>Multiply by</i>	<i>To change</i>	<i>To</i>	<i>Multiply by</i>
inches	centimeters	2.540	ounce-inches	newton-meters	.007062
feet	meters	.305	centimeters	inches	.394
yards	meters	.914	meters	feet	3.280
miles	kilometers	1.609	meters	yards	1.094
square inches	square centimeters	6.451	kilometers	miles	.621
square feet	square meters	.093	square centimeters	square inches	.155
square yards	square meters	.836	square meters	square feet	10.764
square miles	square kilometers	2.590	square meters	square yards	1.196
acres	square hectometers	.405	square kilometers	square miles	.386
cubic feet	cubic meters	.028	square hectometers	acres	2.471
cubic yards	cubic meters	.765	cubic meters	cubic feet	35.315
fluid ounces	milliliters	29.573	cubic meters	cubic yards	1.308
pints	liters	.473	milliliters	fluid ounces	.034
quarts	liters	.946	liters	pints	2.113
gallons	liters	3.785	liters	quarts	1.057
ounces	grams	28.349	liters	gallons	.264
pounds	kilograms	.454	grams	ounces	.035
short tons	metric tons	.907	kilograms	pounds	2.205
pound-feet	newton-meters	1.356	metric tons	short tons	1.102
pound-inches	newton-meters	.11296			

Temperature (Exact)

 °F Fahrenheit temperature $\times \frac{5}{9}$ (after subtracting 32) = Celsius temperature °C

PIN: 059981-000